

VS-500

Voltage Controlled SAW Oscillator

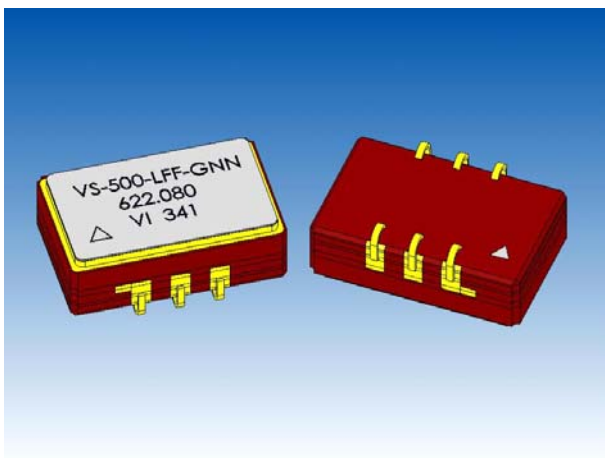

Features

- Improved High Performance ASIC
- Industry Standard Package, 9 x 14 x 4.5 mm
- Output Frequencies from 155 MHz to 850 MHz
- 3.3 V or 5.0 V Operation
- At 155.52 MHz, Jitter < 0.50 ps-rms (12 kHz to 20 MHz)
- At 622.08 MHz, Jitter < 0.30 ps-rms (50 kHz to 80 MHz)
- LV-PECL, PECL, or ECL Configurations
- Complementary Outputs
- Output Disable Feature



Product is free of lead and compliant to EC RoHS Directive

Applications

PLL circuits for Clock Smoothing and Frequency Translation

Description

- 10G Fibre Channel
- 10GbE LAN / WAN
- OC-192
- SONET / SDH

Standard

- INCITS/T11 Project 1413-D
- IEEE 802.3ae
- ITU-T G.709
- GR-253-CORE Issue3

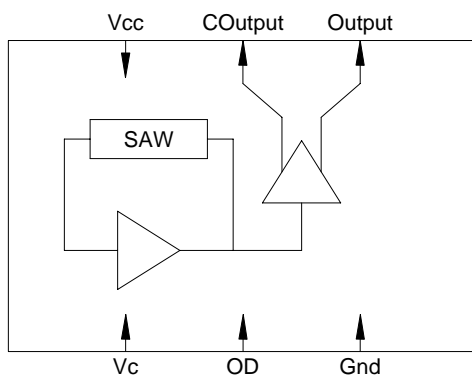

Description

The VS-500 is a SAW based voltage controlled oscillator that operates at the fundamental frequency of the internal SAW filter. This resonator is a high Q quartz device that enables the circuit to achieve low phase jitter performance over a wide operating temperature range. The oscillator is housed in a hermetically sealed J-lead surface mount package offered on tape and reel. It has an output disable to facilitate on-board testing.

VS-500 Voltage Controlled SAW Oscillator

Electrical Performance

| Parameter | Symbol | Minimum | Typical | Maximum | Units | Notes |
|---|------------|------------------|--------------|--------------|-----------|------------|
| Frequency | | | | | | |
| Nominal Frequency | f_N | | 150 - 850 | | MHz | 1,2,3 |
| Absolute Pull Range | APR | ±50 | | | ppm | 1,2,3,9/10 |
| Linearity | Lin | | ±5 | | % | 2,4,9/10 |
| Gain Transfer @ 155.52 MHz (See Pg 5/6) | K_V | | +691/+435 | | ppm/V | 2,9/10 |
| Gain Transfer @ 622.08 MHz (See Pg 5/6) | K_V | | +434/+281 | | ppm/V | 2,9/10 |
| Temperature Stability @ 155.52 MHz | f_{STAB} | | ±100 | | ppm | 1,6 |
| Temperature Stability @ 622.08 MHz | f_{STAB} | | ±150 | | ppm | 1,6 |
| Supply | | | | | | |
| Voltage | V_{CC} | 2.97/4.5 | 3.3/5.0 | 3.63/5.5 | V | 2,3 |
| Current (No Load) | I_{CC} | | 55 | 80 | mA | 3 |
| Outputs | | | | | | |
| Mid Level | | $V_{CC}-1.5$ | $V_{CC}-1.3$ | $V_{CC}-1.1$ | V | 2,3 |
| Swing | | | 850 | | mV-pp | 2,3 |
| Current | I_{OUT} | | | 20 | mA | 6 |
| Rise & Fall Time | t_R, t_F | | 250 | 400 | ps | 5,6 |
| Symmetry | SYM | 45 | 50 | 55 | % | 2,3 |
| Spurious Suppression | | 50 | 60 | | dBc | 6 |
| Jitter @ 155.52 MHz (See Pg 5/6) | ϕ_J | | 0.440 | | ps-rms | 6,7 |
| Jitter @ 622.08 MHz (See Pg 5/6) | ϕ_J | | 0.230 | | ps-rms | 6,8 |
| Control Voltage | | | | | | |
| Input Impedance (LV-PECL or PECL) | Z_c | | 100 | | $k\Omega$ | 6 |
| Input Impedance (ECL) | Z_c | | 10 | | $k\Omega$ | 6 |
| Modulation Bandwidth | BW | | 500 | | kHz | 6 |
| Operating Temperature | | | | | | |
| | T_{OP} | -40 | | 85 | °C | 1,3 |
| Package Size | | | | | | |
| | | 9.0 x 14.0 x 4.5 | | | mm | |

1. See Standard Frequencies and Ordering Information (Pg 8).
2. Parameters are tested with production test circuit below (Fig 2).
3. Parameters are tested at ambient temperature with test limits guardbanded for specified operating temperature.
4. Measured as the maximum deviation from the best straight-line fit, per MIL-0-55310.
5. Measured from 20% to 80% of a full output swing (Fig 1).
6. Not tested in production, guaranteed by design, verified at qualification.
7. Integrated across 12 kHz to 20 MHz, per GR-253-CORE Issue3.
8. Integrated across 50 kHz to 80 MHz, per GR-253-CORE Issue3.
9. Tested with $V_c = 0.3V$ to $3.0V$.
10. Tested with $V_c = 0.5V$ to $4.5V$.

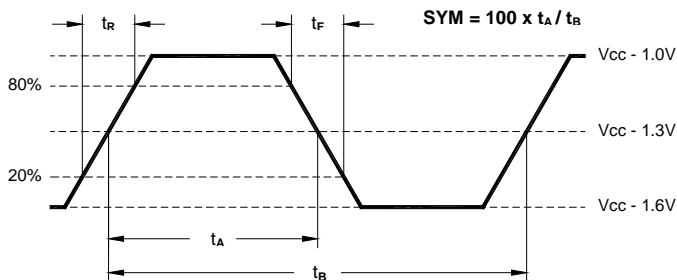
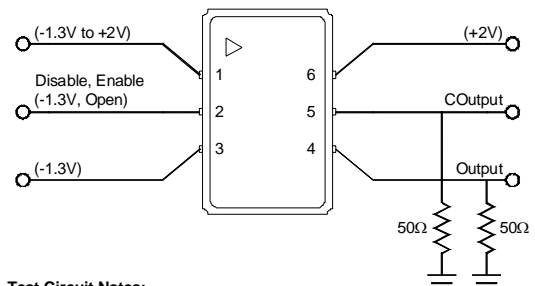

Figure 1. 10K LV-PECL Waveform



Test Circuit Notes:

- 1) To Permit 50Ω Measurement of Outputs, all DC Inputs are Biased Down 1.3V.
- 2) All Voltage Sources Contain Bypass Capacitors to Minimize Supply Noise.
- 3) 50Ω Terminations are Within Test Equipment.

Figure 2. 3.3V Test Circuit

VS-500 Voltage Controlled SAW Oscillator

Outline Diagram

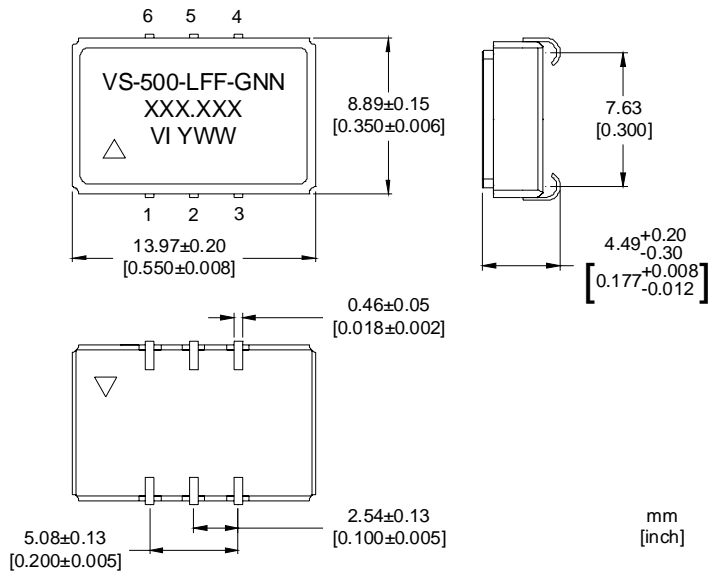

Pad Layout

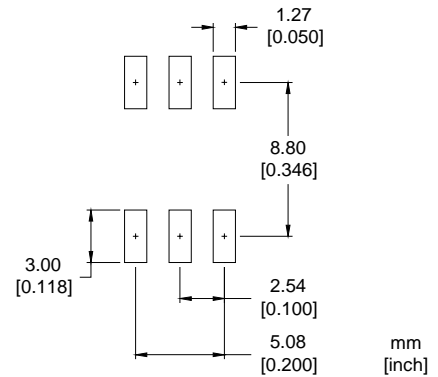

Pin Out

| Pin | Symbol | Function |
|-----|-----------------|---|
| 1 | V _c | VCSO Control Voltage |
| 2 | OD | Output Disable* Disabled = LV-CMOS Logic 0 (or GND) Enabled = LV-CMOS Logic 1 (or Open) |
| 3 | GND | Case and Electrical Ground |
| 4 | Output | VCSO Output |
| 5 | COutput | VCSO Complementary Output |
| 6 | V _{cc} | Power Supply Voltage (3.3V / 5.0V ±10%) |

*For 5.0V Operation, CMOS Levels Should Be Applied.

Tape and Reel (EIA-481-2-A)

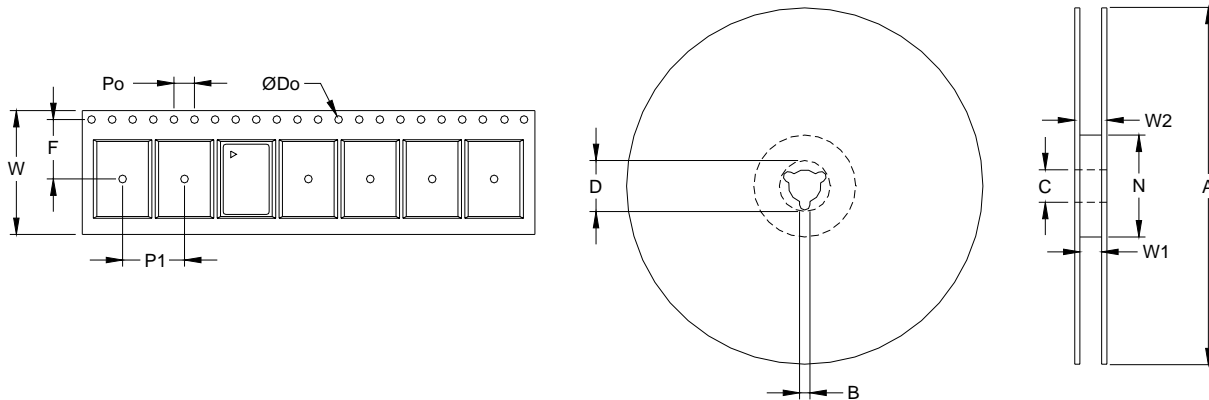

Tape Dimensions (mm) | Reel Dimensions (mm)

| Dimension | W | F | Do | Po | P1 | A | B | C | D | N | W1 | W2 | # Per Reel |
|-----------|-----|------|-----|-----|-----|-----|-----|-----|------|-----|------|------|------------|
| Tolerance | Typ | Typ | Typ | Typ | Typ | Typ | Min | Typ | Min | Min | Typ | Max | Reel |
| VS-500 | 24 | 11.5 | 1.5 | 4 | 12 | 330 | 1.5 | 13 | 20.2 | 100 | 24.4 | 30.4 | 200 |

VS-500 Voltage Controlled SAW Oscillator

Absolute Maximum Ratings

| Parameter | Symbol | Ratings | Unit |
|-----------------------|-----------|---------------|--------|
| Power Supply | V_{CC} | 0 to 6 | V |
| Output Current | I_{out} | 25 | mA |
| Voltage Control Range | V_C | 0 to V_{CC} | V |
| Storage Temperature | TS | -55 to 125 | °C |
| Soldering Temp/Time | T_{Ls} | 220/10 | °C/sec |

Stresses in excess of the absolute maximum ratings can permanently damage the device. Functional operation is not implied at these or any other conditions in excess of conditions represented in the operational sections of this datasheet. Exposure to absolute maximum ratings for extended periods may adversely affect device reliability.

Suggested Output Load Configurations (3.3V Operation)

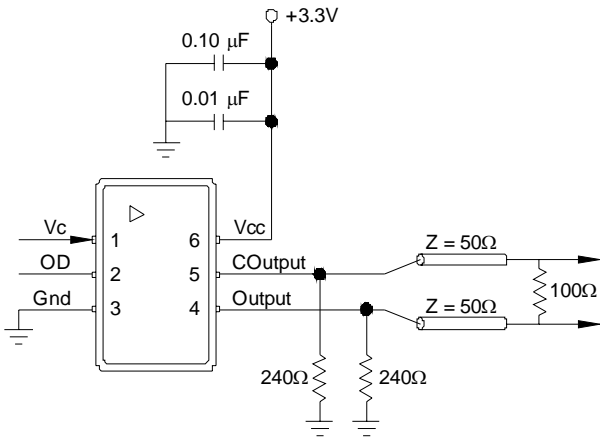

LV-PECL to LV-PECL: For short transmission lengths, the power consumption could be reduced by removing the 100Ω resistor and doubling the value of the pull down resistors.

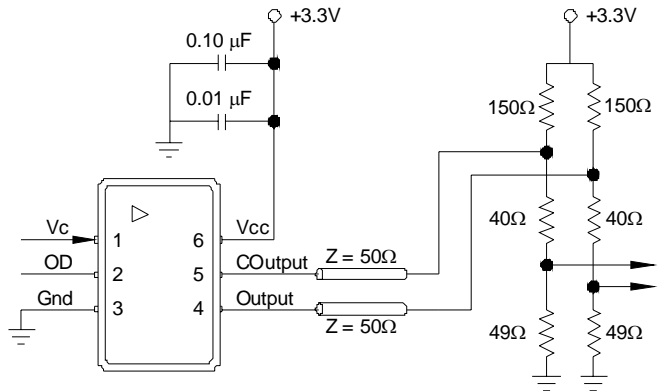

LV-PECL to LVDS: Restricted for short transmission lengths. Configuration may require modification depending on LVDS receiver.

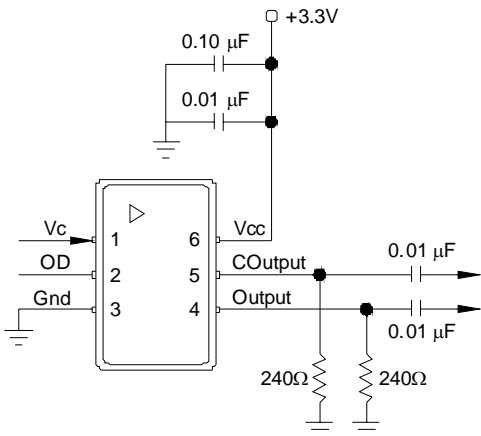

Functional Test: Allows standard power supply configuration. Since AC coupled, the LV-PECL levels cannot be measured.

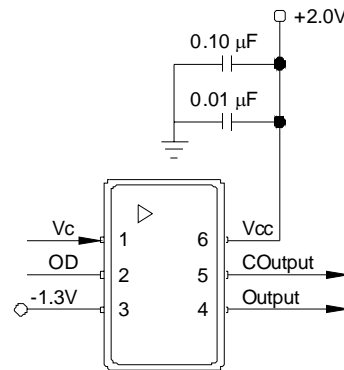

Production Test: Allows direct DC coupling into 50Ω measurement equipment. Must bias the power supplies as shown. Similar to Figure 1.

VS-500 Voltage Controlled SAW Oscillator

Typical Characteristics (3.3V Operation)

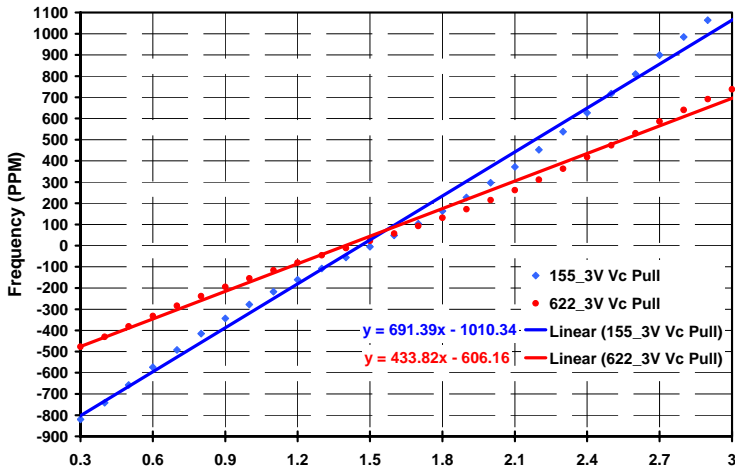

Vc Pull Characteristics (22.5 °C)
 Typical Gain Transfer @ 155.52 = +691 ppm/V
 Typical Gain Transfer @ 622.08 = +434 ppm/V

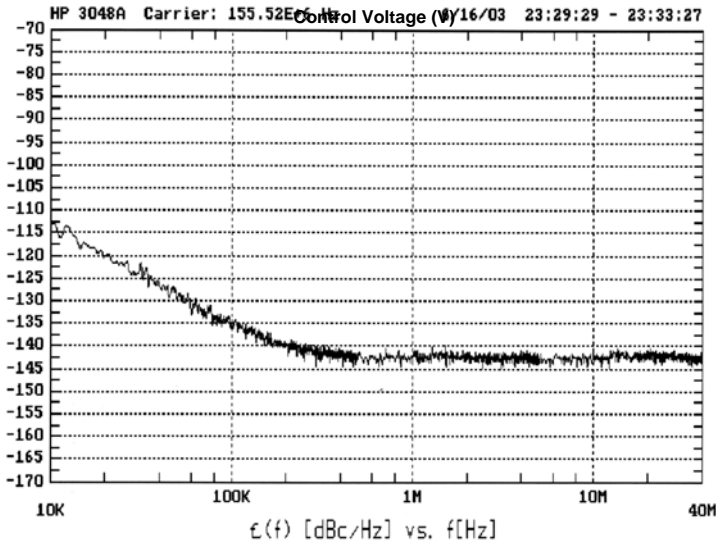

Calculated Jitter @ 155.52 MHz (22.5 °C)
 SONET OC-48 (12kHz-20MHz) = 0.442 ps-rms; 3.09 ps-pp
 SONET OC-192 (50kHz-80MHz) = 0.685 ps-rms; 4.80 ps-pp

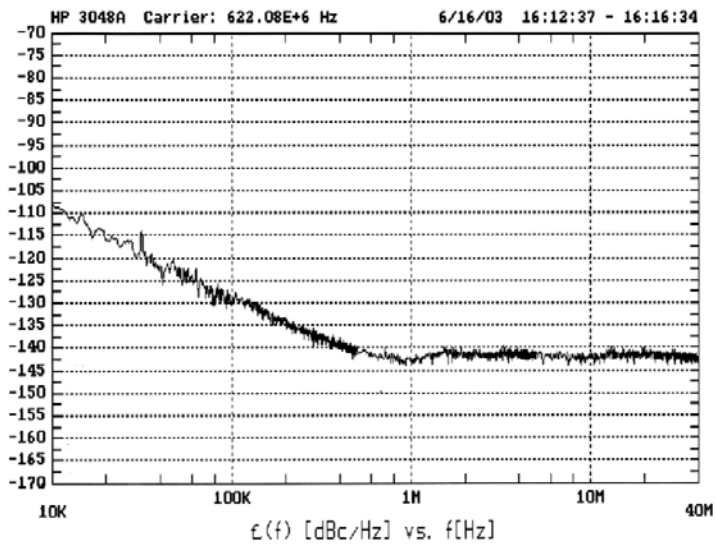

Calculated Jitter @ 622.08 MHz (22.5 °C)
 SONET OC-48 (12kHz-20MHz) = 0.244 ps-rms; 1.71 ps-pp
 SONET OC-192 (50kHz-80MHz) = 0.214 ps-rms; 1.50 ps-pp

VS-500 Voltage Controlled SAW Oscillator

Typical Characteristics (5.0V Operation)

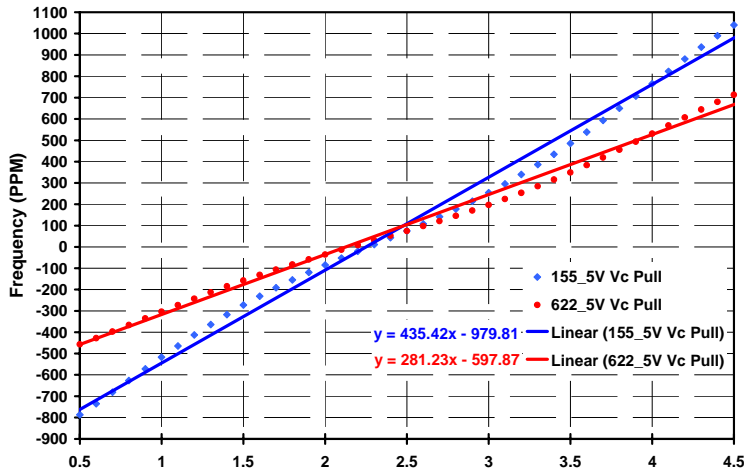

Vc Pull Characteristics (22.5 °C)

Typical Gain Transfer @ 155.52 = +435 ppm/V

Typical Gain Transfer @ 622.08 = +281 ppm/V

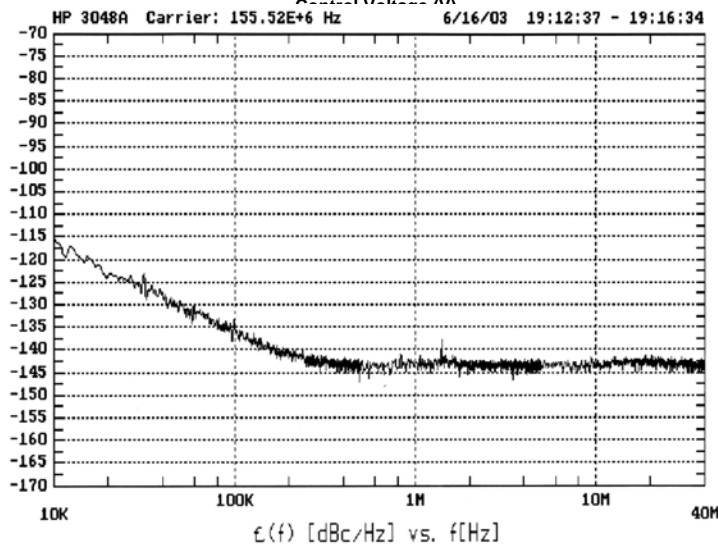

Calculated Jitter @ 155.52 MHz (22.5 °C)

SONET OC-48 (12kHz-20MHz) = 0.418 ps-rms; 2.93 ps-pp

SONET OC-192 (50kHz-80MHz) = 0.656 ps-rms; 4.59 ps-pp

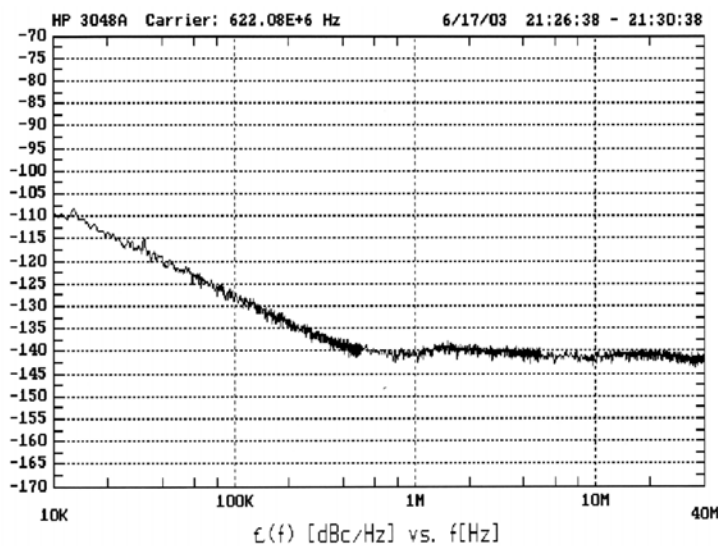

Calculated Jitter @ 622.08 MHz (22.5 °C)

SONET OC-48 (12kHz-20MHz) = 0.215 ps-rms; 1.51 ps-pp

SONET OC-192 (50kHz-80MHz) = 0.226 ps-rms; 1.58 ps-pp

VS-500 Voltage Controlled SAW Oscillator

Reliability

The VS-500 family is capable of meeting the following qualification tests:

Environmental Compliance

| Parameter | Conditions |
|------------------------|--------------------------|
| Mechanical Shock | MIL-STD-883, Method 2002 |
| Mechanical Vibration | MIL-STD-883, Method 2007 |
| Solderability | MIL-STD-883, Method 2003 |
| Gross and Fine Leak | MIL-STD-883, Method 1014 |
| Resistance to Solvents | MIL-STD-883, Method 2016 |

Handling Precautions

Although ESD protection circuitry has been designed into the VS-500 proper precautions should be taken when handling and mounting. VI employs a human body model and a charged-device model (CDM) for ESD susceptibility testing and design protection evaluation.

ESD Ratings

| Model | Minimum | Conditions |
|----------------------|---------|--------------------------|
| Human Body Model | 1500 V | MIL-STD 883, Method 3015 |
| Charged Device Model | 1000 V | JESD 22-C101 |

Reflow Profile (IPC/JEDEC J-STD-020C)

| Parameter | Symbol | Value |
|--------------------------|-------------|-------------------------|
| PreHeat Time | t_s | 60 sec Min, 180 sec Max |
| Ramp Up | R_{UP} | 3 °C/sec Max |
| Time Above 217 °C | t_L | 60 sec Min, 150 sec Max |
| Time To Peak Temperature | t_{AMB-P} | 480 sec Max |
| Time At 260 °C | t_P | 20 sec Min, 40 sec Max |
| Ramp Down | R_{DN} | 6 °C/sec Max |

The device has been qualified to meet the JEDEC standard for Pb-Free assembly. The temperatures and time intervals listed are based on the Pb-Free small body requirements. The temperatures refer to the topside of the package, measured on the package body surface. The VS-500 device is hermetically sealed so an aqueous wash is not an issue.

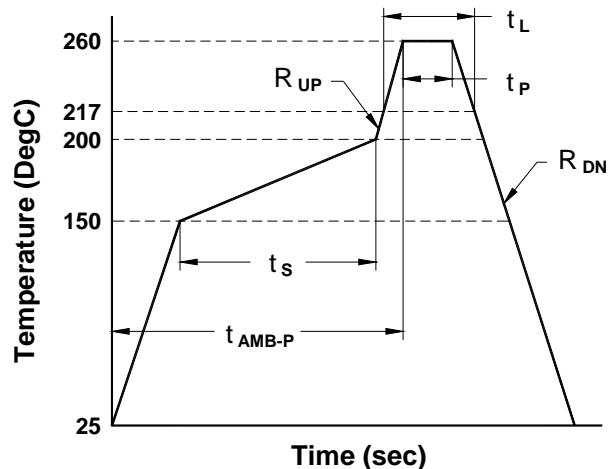

VS-500 Voltage Controlled SAW Oscillator

| Standard Frequencies (MHz) | | | | | |
|----------------------------|----------|----------|----------|----------|----------|
| 155.5200 | 156.2500 | 159.3750 | 161.1328 | 164.3555 | 166.6286 |
| 167.3316 | 177.7371 | 311.0400 | 320.0000 | 400.0000 | 537.6000 |
| 622.0800 | 624.7048 | 625.0000 | 627.3296 | 629.9878 | 640.0000 |
| 644.5313 | 657.4219 | 666.5143 | 669.3266 | 669.6429 | 670.8386 |
| 672.1627 | 690.5692 | 693.4830 | 693.7500 | 716.5372 | 718.7500 |
| 719.7344 | 748.0709 | 750.0000 | 779.5686 | 781.2500 | 805.6641 |

Other Frequencies Available Upon Request.

Ordering Information

VS - 500 - L F F - G N N - xxx.xxx

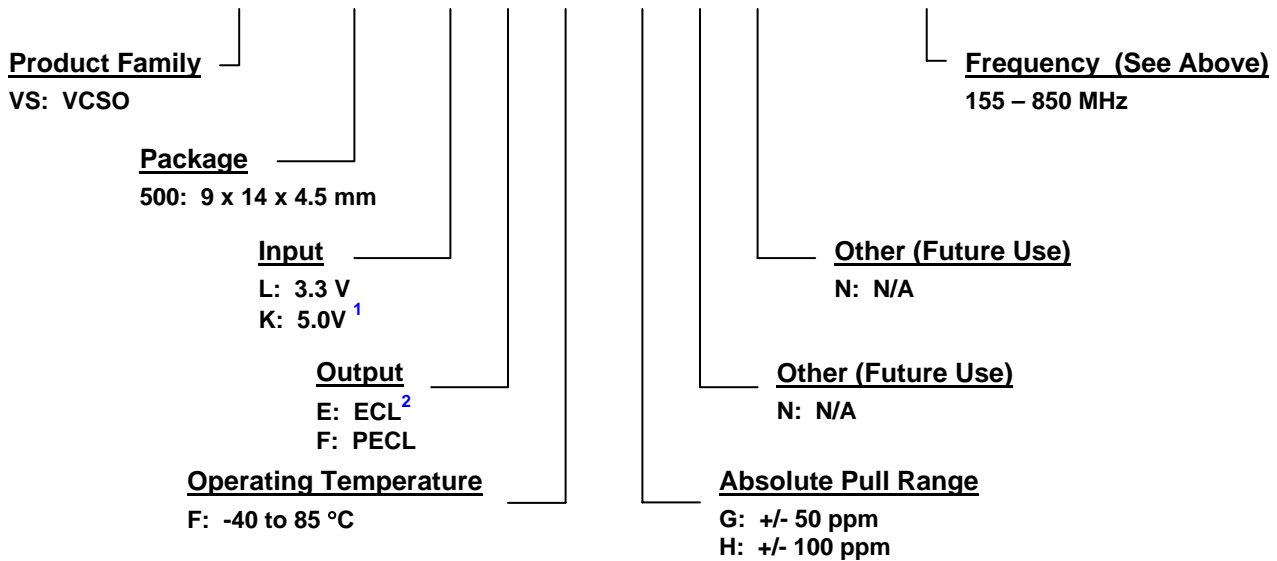

¹For all new 5.0V supply requirements, PECL output configuration is suggested. ²ECL “E” Is Only Available In 5.0V “K” Configuration and is offered to make the Vc Input Impedance backward compatible with the VS-500A & VS-500F products. For further information, please contact your local Vectron Marketing Representative.

Part Number Cross Reference

| Old Part Number | New Part Number |
|-----------------|-----------------|
| VS-500A | VS-500-KEF-GNN |
| VS-500F | VS-500-KEF-HNN |

For Additional Information, Please Contact:



USA: Vectron International, 267 Lowell Rd, Hudson, NH 03051 Tel: 1-88-VECTRON-1 Fax: 1-888-FAX-VECTRON
 EUROPE: Tel: +49 (0) 3328-4784-17 Fax: +49 (0) 3328-4784-30
 ASIA: Tel: +86-21-28909740 Fax: +86-21-28909999

Vectron International reserves the right to make changes to the product(s) and or information contained herein without notice. No liability is assumed as a result of their use or application. No rights under any patent accompany the sale of any such product(s) or information.