

PART NAME: KNOB

SCALE: 1:1

DATE: 8/1/50

DR. BY HAC



DESIGNERS & MANUFACTURERS OF KNOBS, HANDLES, CASES & CUSTOM PLASTIC COMPONENTS

P/N 1475-A

THIS DRAWING IS THE PROPERTY OF DAVIES MOLDING COMPANY, IS SUBMITTED SOLELY AS A DESIGN OR ENGINEERING PROJECT. WE ACCEPT NO RESPONSIBILITY WHATSOEVER FOR THE PRACTICAL APPLICATION OF THE PIECES MADE TO THIS DESIGN.

BASE PART 1475-11

SPRING I1125A

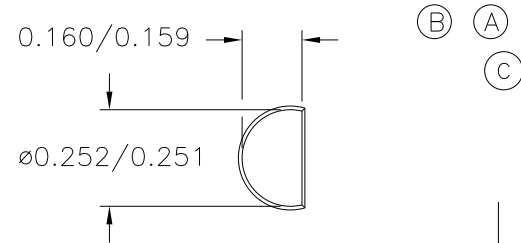

MOLDED HOLE SCALE 2:1

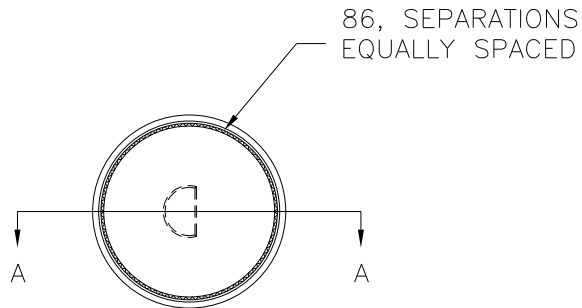

SECTION A-A

NOTE : AFTER MOLDING THIS PART(S) SPRING I-1125A MUST BE INSTALLED IN FINISHING DEPT. FOR COMPLETED PART AS # 1475-A

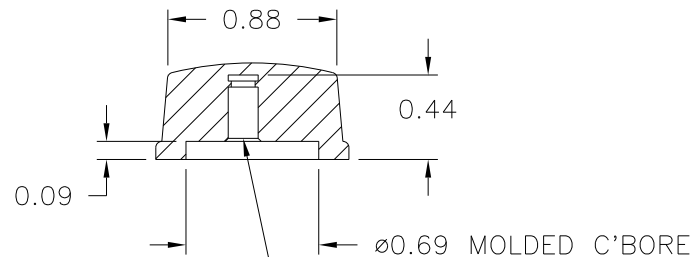
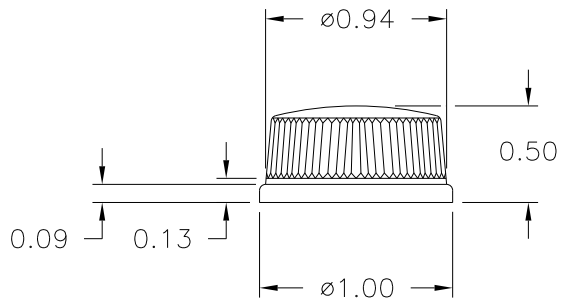

"D" SHAPE MOLDED HOLE FOR SPRING I1125A

MATERIAL: G.P. PHENOLIC (B11)
COLOR: BLACK

TOLERANCES: UNLESS OTHERWISE SPECIFIED	DO NOT SCALE DRAWING	C	ADDED BASE PART	EW	6/30/14
		B	REDRAWN/WAS I0376	HD	10/28/93
DECIMALS: X.XXX ± .005 X.XX ± .015	MM: X.XX ± 0.15MM X.X ± 0.4MM	A	WAS I0328	LSP	3/25/57
FRACTIONS ± 1/64	ANG. ± 1°	CHANGES			