



MICRF302

Parallel Encoder

General Description

The MICRF302 is a parallel encoder which works with QwikRadio® family radios to significantly shorten design time for RF products. The part is easy to use, provides more communication distance, and it is extremely stable over operating temperature and operating voltage range.

The MICRF302 Parallel Encoder makes the transmission of encoding data simple. This device encodes data from four input pins, which have internal pull-up resistors and deglitching circuitry. These inputs can be connected to switches or external circuitry. The MICRF302 outputs encoded data serially, and can be connected directly to any QwikRadio® transmitter without any additional components.

The MICRF302 gives communication reliability through built-in CRC (cyclic redundancy check). The MICRF302 needs no external components for clock generation. Unlike other encoders on the market, there is no shift in performance with associated changes in operating temperature nor operating voltage. The internal clock provides stable data operations over a wide temperature range of -40°C to +85°C. MICRF302 can operate from 1.8 V to 3.6 V. The MICRF302 is battery friendly, and will work with alkaline, NiCd, NiMh, lithium ion, or lithium batteries.



QwikRadio®

Features

- Small form factor: 10-pin MLF® package
- Wide operating voltage range: 1.8 V to 3.6 V
- Low current consumption: 130µA operating, 0.1µA Standby
- On-chip clock generation requires no external components
- Unique 20-bit internal address allows up to 1 million combinations to differentiate from adjacent encoders.
- Selectable data rates: 0.6, 1, 3, 4.8kbps
- 8-bit industry-standard CRC provides robust data protection
- On-chip pullup resistors
- On-chip deglitch makes it easy to use low-cost switches

Applications

- Light switches
- Appliance controls
- Christmas lights
- Fan and HVAC switches
- Remote half switches
- Garage door openers
- Remote controls
- Toys
- Lawn watering sensors
- Robust, unidirectional, low cost, low power, low data rate communications links

Ordering Information

Part Number	Marking Code	Temperature Range	Package
MICRF302YML	XA02	-40°C to +85°C	10-pin 2.5mm × 2.5mm MLF®

Note:

1. MLF is a GREEN RoHS compliant package. Lead finish is NiPdAu. Mold compound is Halogen Free.

QwikRadio is a registered trademark of Micrel, Inc.

MLF and MicroLead Frame are registered trademark of Amkor Technology

Micrel Inc. • 2180 Fortune Drive • San Jose, CA 95131 • USA • tel +1 (408) 944-0800 • fax +1 (408) 474-1000 • <http://www.micrel.com>

Typical Application

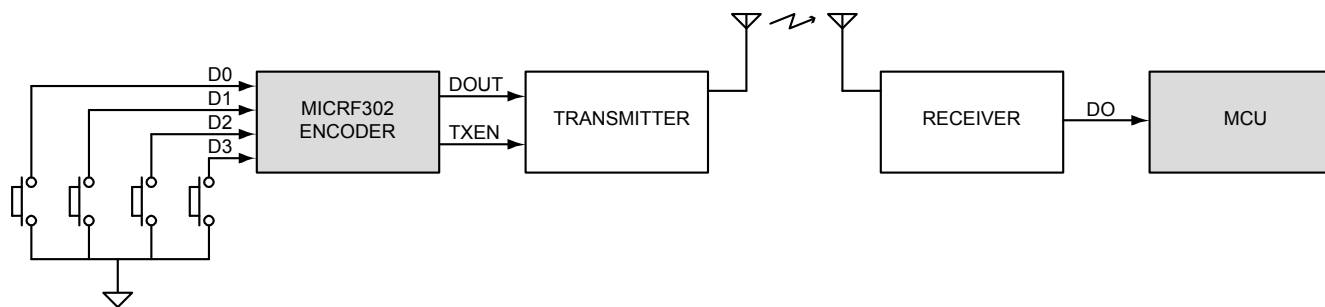

Figure 1. RF Link

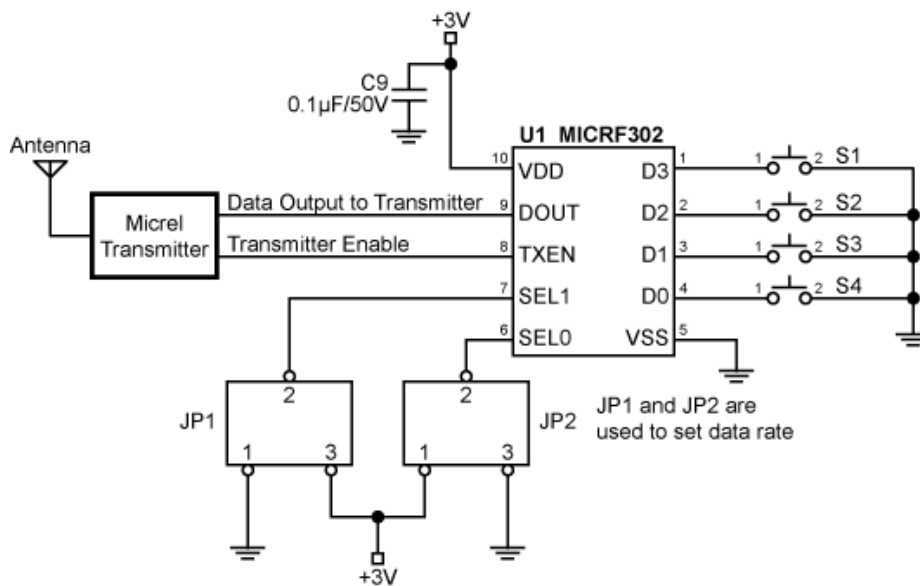
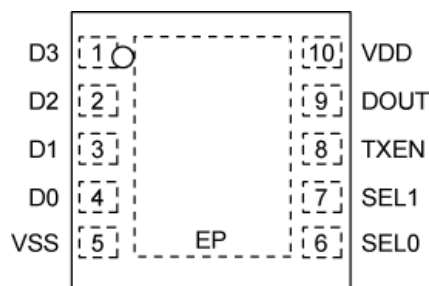

Figure 2. MICRF302 and Micrel Transmitter

Pin Configuration



10-Pin MLF[®] Package

Pin Description

Pin Number	Pin Name	Pin Function
D3	1	Switch Input 3
D2	2	Switch Input 2
D1	3	Switch Input 1
D0	4	Switch Input 0 Typical applications connect D0-D3 to ground with a push-button switch. Unused switch inputs can just be left unconnected. D0-D3 are deglitched by the MICRF302; pulses shorter than 8 ms are rejected.
VSS	5	Negative Supply (Ground)
SEL0	6	Data rate select 0
SEL1	7	Data rate select 1 The data rate select pins must be connected to VDD or VSS, and select the data rate as follows: 00: 600 bps 01: 1 kbps 10: 3 kbps 11: 4.8 kbps
TXEN	8	Transmitter Enable The active-high enable turns on a companion transmitter 40 ms before baseband data transmission starts. This delay allows the Transmitter's PLLs to lock.
DOUT	9	RF Baseband Data Output Data from the MICRF302 is Manchester-coded.
VDD	10	Positive Supply

Absolute Maximum Ratings⁽¹⁾

Supply Voltage (V_{DD})	-0.3 V to +4 V
Voltage on Any Pin	$V_{SS} - 0.3$ V to $V_{DD} + 0.3$ V
Junction Temperature	-55°C to +150°C
Storage Temperature	-65°C to +150°C
Lead Temperature (soldering, 10 s)	+300°C
ESD Rating ⁽³⁾	2kV HBM

Operating Ratings⁽²⁾

Supply Voltage (V_{DD})	1.8 V to 3.6 V
Ambient/junction Temperature	-40°C to +85°C

Electrical Characteristics

$V_{IN} = 3.3V$; $T_A = 25^\circ C$, bold values indicate $-40^\circ C \leq T_A \leq +85^\circ C$, unless noted.

Parameter	Condition	Min	Typ	Max	Units
Operating Supply Current	Fully Operational		130	200	μA
Standby Current	Chip Disabled		0.3	1	μA

Analog Section

MICRF302 Parallel Encoder Timing (Note 4)					
On-chip oscillator frequency accuracy	Does not depend on data rate	-10	0	+10	%
One bit time		0.9	1.0	1.1	ms
One packet time			98		ms
Delay between data packets			5		ms
Switch closure to TXEN (TD_TXEN)	Does not depend on data rate		<1		μs
Transmit Timeout ⁽⁶⁾	Does not depend on data rate	22.5	25	27.5	s
Transmit Enable to Data Out (TTXEN_DOUT)		36	40	44	ms
Pulse rejection (deglitch) by D0-D3 (Note 5)	Does not depend on data rate	7.2	8	8.8	ms

Digital Section

Input Low Voltage	D0 to D3 pins			0.1 VDD	V
Input High Voltage	D0 to D3 pins	0.9 VDD			V
Output High Voltage	TXEN/DOUT pin, 1 μA Load	0.9 VDD			V
Output Low Voltage	TXEN/DOUT pin, 1 μA Load			0.1 VDD	V
Output Tr, Tf	TXEN/DOUT pin, Cload = 15pF		10		μs
DOUT and TXEN, Output Current	Source at 0.8 VDD		3		mA
	Sink at 0.2 VDD		10		

Notes:

- Exceeding the absolute maximum rating may damage the device
- The device is not guaranteed to function outside its operating rating
- This device is ESD sensitive
- Timing numbers are for a data rate of 1 kbps. Except where shown, all data timing scales linearly with the data rate.
- In this context, deglitching refers to the D0-D3 pins' ability to reject high- or low-going glitches. Deglitching makes it much easier to use low-cost push-to-make switches which have inherently noisy contacts.
- Guaranteed by design.

Functional Diagram

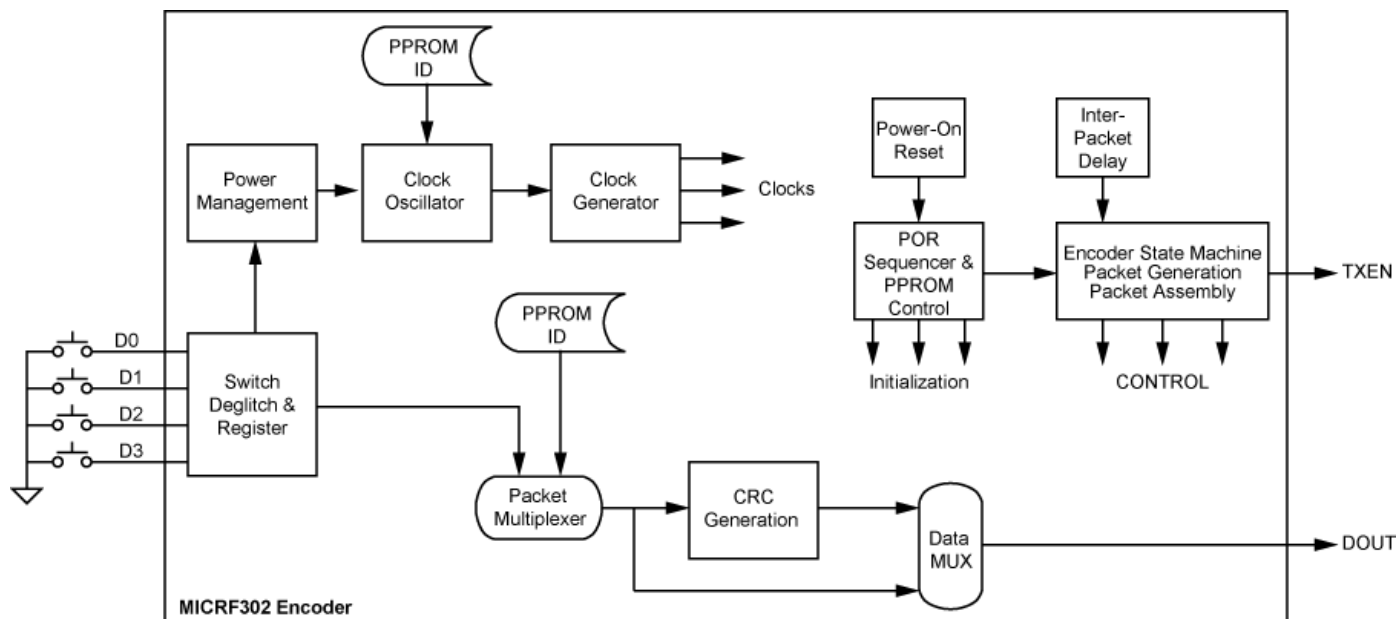

Figure 3. MICRF302 Parallel Encoder Functional Diagram

Functional Description

Overview

The MICRF302 is an encoder that prepares data for transmission across an RF link. It is a parallel encoder, meaning that it provides multiple parallel inputs for connection to low-cost push-button switches.

The MICRF302 encoder translates push button closures, any combination of D0 to D3, into baseband packets using a set of internal logic blocks, which we describe here. Please refer to the Functional Diagram while reading the following paragraphs.

Switch Deglitch and Register

When a button is pushed, the switch input is deglitched to remove transient pulses shorter than 8 ms. The state of the buttons is frozen and registered prior to transmission. If multiple buttons are pushed within one deglitch/sample time, their active levels will all be included in the transmitted data.

Power Management

Immediately after any switch closure, the MICRF302 wakes from its standby (low-power) state and asserts the TXEN output to start the RF transmitter. The Power Management circuitry keeps the MICRF302 active during packet transmission, then supervises the transition back to the standby state.

Clock Oscillator

The on-chip, trimmed oscillator is started by the Power Management logic after startup (button press). It times all internal events and sets the bit rate of the baseband data via the clock generator. The clock oscillator maintains its set frequency with a tolerance of $\pm 10\%$ over process, voltage, and temperature variations

PPROM Trim

The Poly-fuse Programmable Read-Only Memory stores the MICRF302's unique address (see the PPROM ID block), as well as other necessary information.

Power-On Reset

This self-contained, on-chip reset generator manages the behavior of the MICRF302 when power is initially applied, for example when a battery is inserted into the transmitter. The POR sequencer and PPROM control logic powers up the PPROM, loads important information into internal registers, powers down the PPROM, and then puts the whole chip into its standby state, ready for the first button push event.

Packet Multiplexor

The packet multiplexor chooses the appropriate information for the MICRF302 to build and transmit a packet. Under direction of the encoder state machine, packet generation, packet assembly logic, the packet multiplexor serializes the entire packet. The packet consists of: preamble, dead time, sync field, address, and data. The packet multiplexor feeds into CRC generation and data mux sections. CRC Generation computes the industry-standard 8-bit CRC. The data mux chooses the right information to be sent to the transmitter. The data mux also ensures that the DOUT pin is inactive when no packet transmission is in progress.

Inter-Packet Delay

Getting its timing information from the Clock Generator, the inter-packet delay block inserts the correct delay between the four packets in a set. After each inter-packet delay, the packet is repeated, increasing the probability of accurate detection at the receiver.

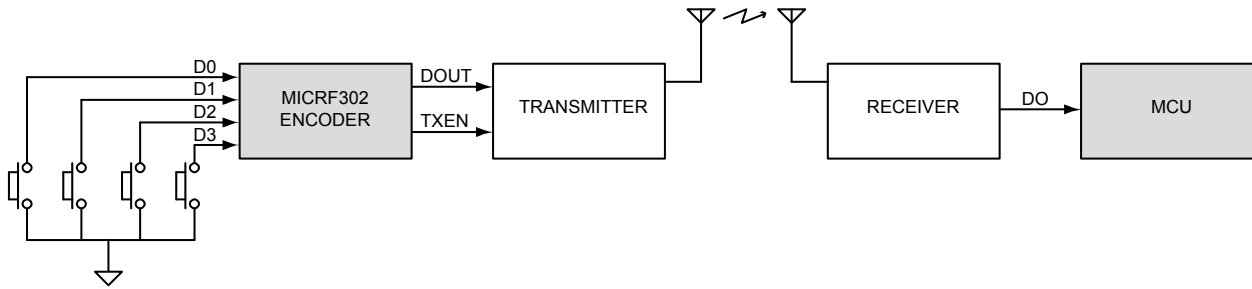

Figure 4. Parallel Encoder / Decoder Configuration



Figure 5. Data Transmission Packet Format

Operation Overview

The Figure 4 shows the basic operation of a parallel encoder/decoder configuration. When a button is pushed (known as a push event), the MICRF302 Encoder sends packets of data to the transmitter. Each packet contains encoded data bits, suitable for transmission across an ASK or FSK RF communications channel. The receiver demodulates the baseband information from the RF carrier, which is then decoded by the MCU.

Data Transmission

In any communications link we must be sure that the decoder puts out what the encoder puts in. Lost data is acceptable when the encoder and decoder are out of range, but incorrect data is completely unacceptable when the encoder and decoder are within range. Micrel’s MICRF302 uses an error management hierarchy to prevent bad data getting through the link:

1. Data is encoded using RF receiver-friendly Manchester encoding
2. An industry-standard CRC (Cyclic Redundancy Check) ensures that data is good before being accepted by the decoder
3. Data is sent in packets. Each packet has a preamble, sync field, and a payload. Packets are sent in groups of four. So even though four identical packets are transmitted, a single valid packet received by the Decoder is sufficient to change the Decoder’s outputs. Please see operating manual of the MICRF302 for details.

Packet Format

Each data packet consists of a number of fields, shown in Figure 5. A packet consists of six fields:

1. Preamble (32 bits, all zero) is for receiver and

decoder wakeup and synchronization

2. Dead Time (3 bit-times) allows the receiver’s AGC to increase its sensitivity
3. Sync (four bits, 1111) identifies the end of the preamble and the start of the payload
4. DEVADR—20 bits of Device Address—identifies one unique Encoder that’s transmitting. decoders compare the DEVADR field against their own value and only accept the packet if a match is found. The 20-bit device address is programmed at the factory to a unique value for each part.
5. Data (8 bits) carries the “real” information within the packet.
6. CRC—Cyclic Redundancy Check—(8 bits) lets the Decoder check for errors in the packet

Data Format

Manchester-coded data has two distinguishing features that make it an excellent choice for low-cost RF data exchange:

1. Its 50% duty cycle is very friendly to RF receivers.
2. It always has a transition at the center of every bit (Figure 6). This certainty of a transition simplifies the decoder’s task of recovering the encoder’s clock rate and then actually decoding the data stream.

Manchester-coded data is shown here:

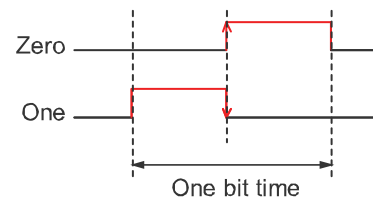

Figure 6. Manchester Coded Data

MICRF302 Parallel Encoder Features

Transmit Timeout

The MICRF302 implements a 25-second (nominal) transmit timeout timer. If a user pushes an MICRF302 button and holds it down, transmission of packets (in repeated groups of four) will continue for no more than 25 seconds. Afterwards, the MICRF302 shuts down and waits to be restarted by another button push. The button must be released before it can be pushed again to restart packet transmission.

The purpose of the transmit timeout is to prevent battery drain and unnecessary transmission where a user might, for example, sit on a remote control.

Preamble/Dead-Time/Sync Format

The MICRF302 sends a lengthy amount of information at the start of the packet to help the decoder synchronize to the incoming data stream. The format is as followed:

1. 32 zeros
2. Three-bit dead time of no Manchester-coded data. This allows the MICRF302 to be used with receivers whose AGC benefits from the presence of a dead time.
3. Four ones (1111) mark the end of the preamble, dead time, and sync. The bit following the last one of the four is the first data bit of the 20-bit DEVADR field.

Inter-Packet Delay

The delay (dead time, no Manchester-coded data) between subsequent packets is always eight bit-times.

Important: Encoder Bit-Time Variation

The frequency of the MICRF302's on-chip oscillator varies by $\pm 10\%$ over supply voltage, temperature, and manufacturing tolerances. It is important to remember that this means that the MICRF302 Encoder's bit time does not vary by $\pm 10\%$; it varies as follows. Consider an MICRF302 Encoder set to transmit at a nominal rate of 1 kHz, with a nominal bit-time of 1 ms. The transmit frequency will then fall in the range of 900 Hz to 1.1 kHz. The corresponding bit-times are 1.111 ms to 0.909 ms. This actually corresponds to a variation in bit-time of -9.1% to $+11.1\%$. It is critical that the decoder accommodate incoming data streams whose bit-times fall within this range, not $\pm 10\%$.

TX Enable

The MICRF302 TXEN is normally low and goes active-high ~ 40 ms before data is seen at the output (Figure 7, 8) and remains high until D0-D3 is deactivated or the internal MICRF302 time out has elapsed (Figure 9).

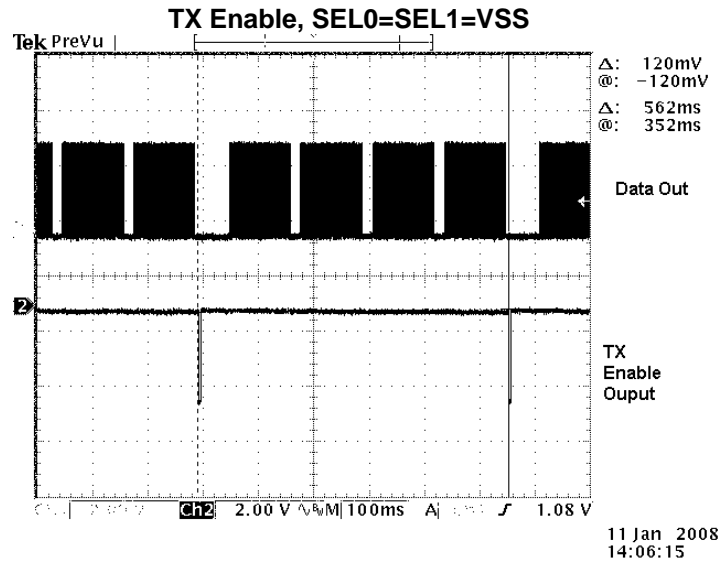

Figure 7. TX Enable Output and Data Output

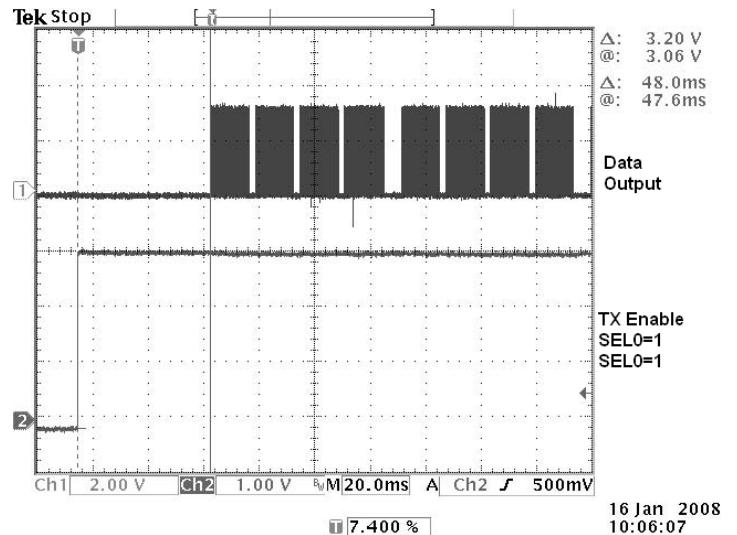

Figure 8. TX Enable Output and Data Output Zoom In

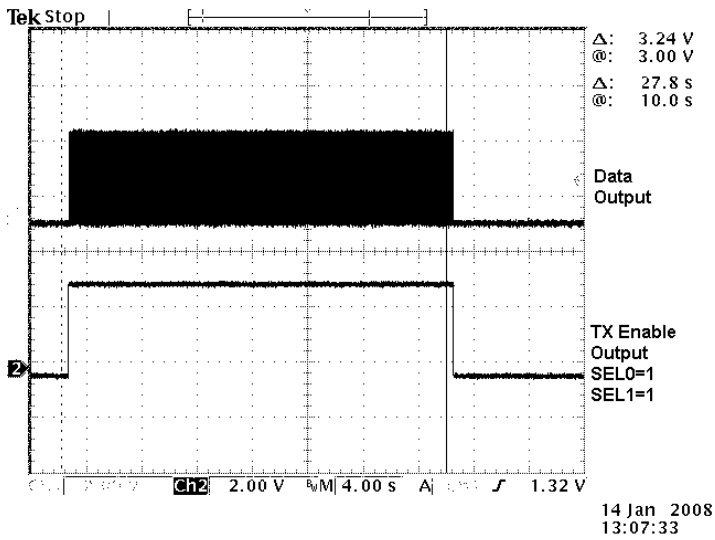

Figure 9. MICRF302 Time

Figure 10 is an example of an RF link when a Micrel MICRF211 radio receiver is used to receive and demodulate a transmitted MICRF302 baseband signal. The MICRF302 Tester or the TX112-MICRF302 KEYFOB can be used to transmit the MICRF302 baseband signal.

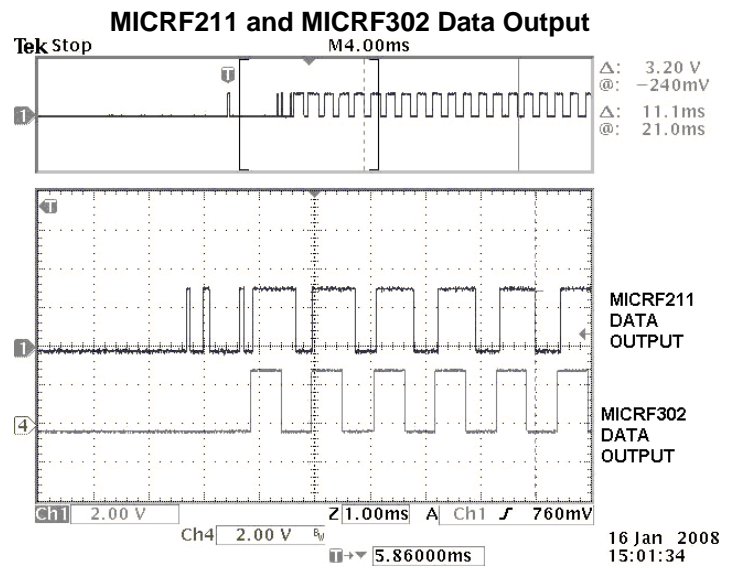

Figure 10. Micrel Receiver Example Receiving MICRF302 Data Output

Application Information

Example: Four Button Transmitter using MICRF302 Encoder and MICRF112 Transmitter Device

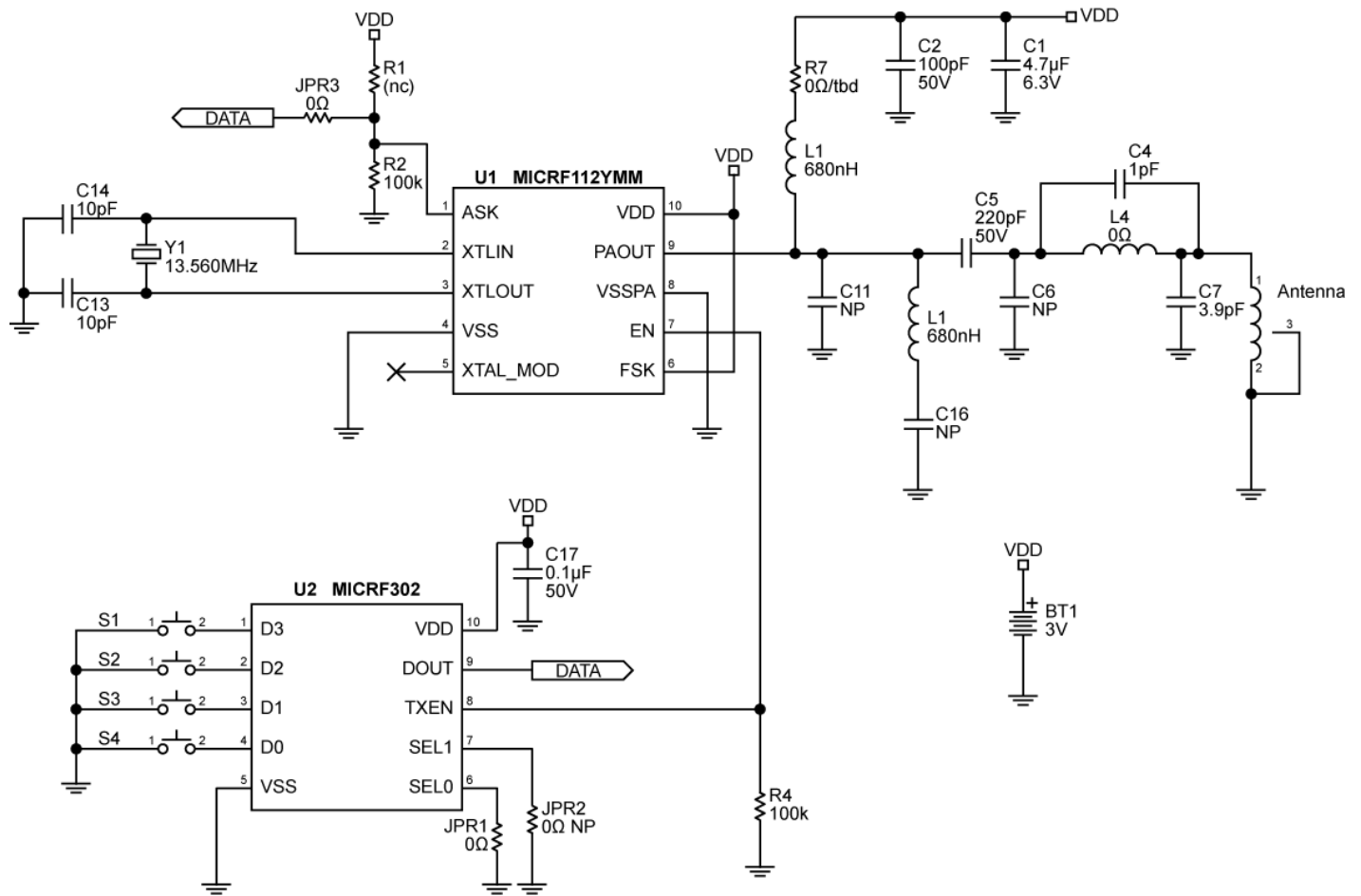

Figure 11. TX112-MICRF302 KEYFOB Evaluation Board Schematic

MICRF302 Decoder Board Assembly

MICRF302 Decoder, Figure 12 uses a QwikRadio® receiver to receive the MICRF302 protocol. The data output of the receiver will go to a Microchip PIC16F689 that has been programmed to decode the MICRF302 protocol. Further details about the design and operation of the decoder/encoder (Figure 16) are available in the MICRF302 Encoder/Decoder Users Guide. Design files are available upon request.

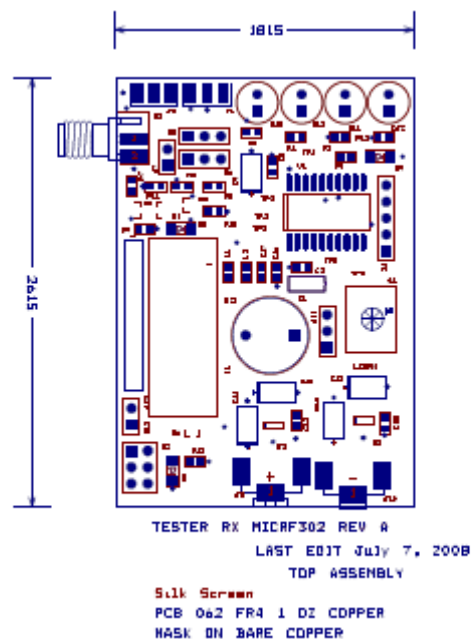

Figure 12. MICRF302 Decoder Assembly

Decoder and Encoder Test Configuration using a Micrel Transmitter and Receiver

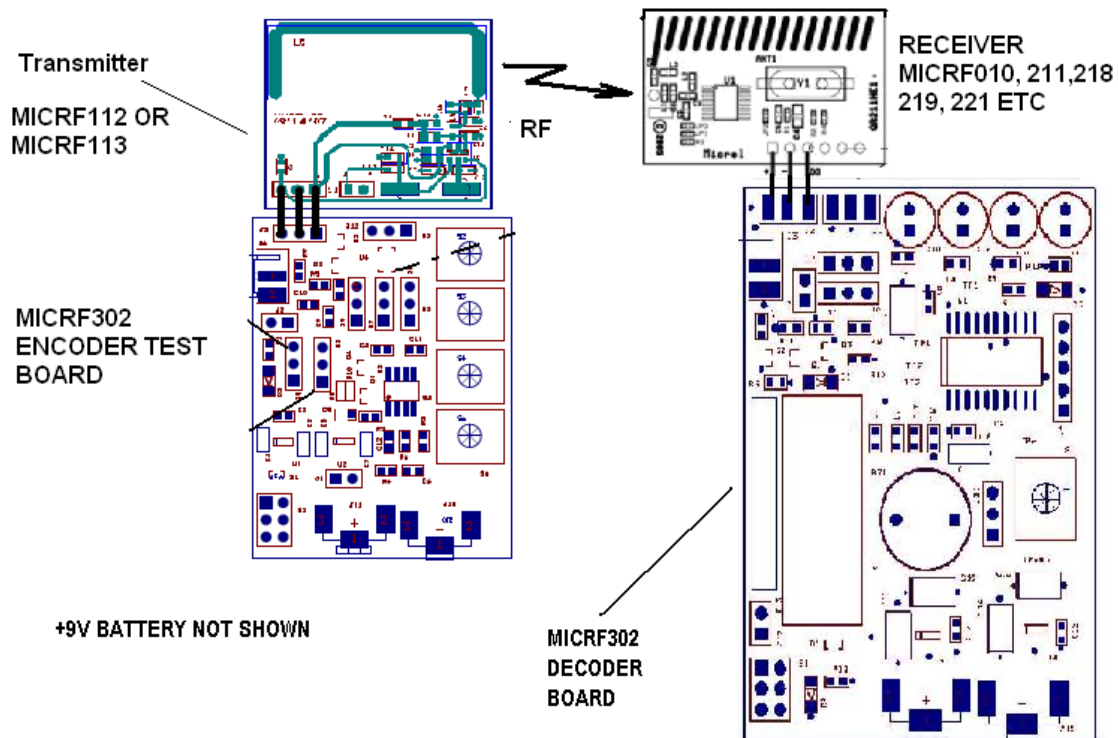

Figure 13. Test Configuration

PCB Board Layout

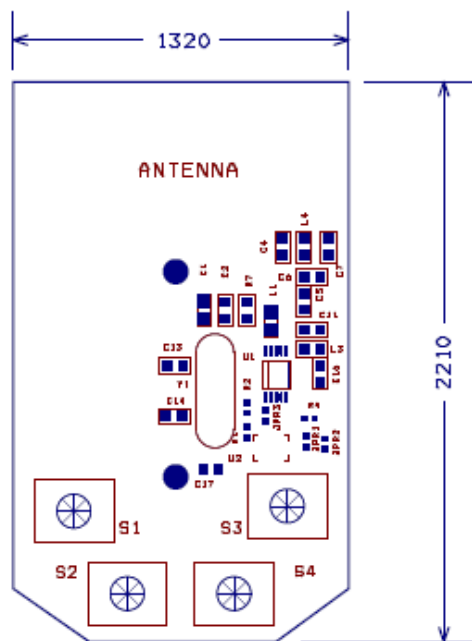

Figure 14. TX112-MICRF302 Evaluation Board Assembly

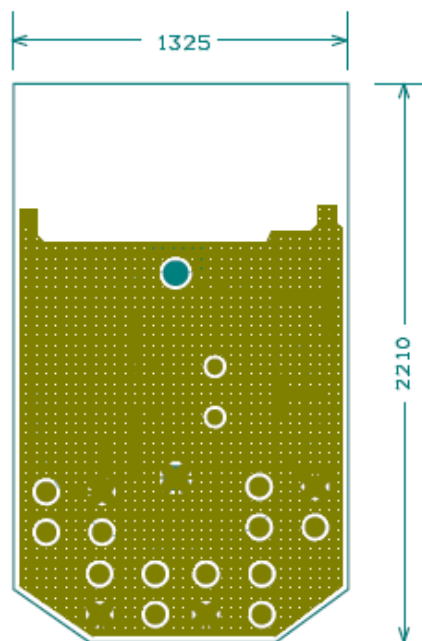

Figure 16. TX112-MICRF302 KEYFOB Evaluation Board, Bottom View

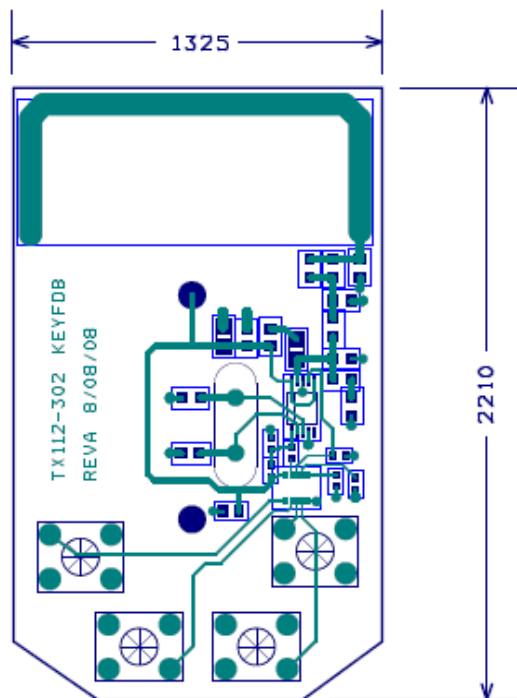

Figure 15. TX112-MICRF302 KEYFOB Evaluation Board, Top View

Bill of Materials**TX112-MICRF302 KEYFOB Evaluation Board Bill of Materials**

Item	Quantity	Reference	Part	PCB Footprint
1	1	ANTENNA	ANTENNA	ANTENNA_LOOP2
2	1	BT1	3 volts, BATTERYHOLDER 23MM/COINCELL/THM	
3	1	C1	4.7uF 6.3V	0805
4	1	C2	100pF 50V	0603
5	1	C4	1pF	0603
6	1	C5	22pF 50V	0603
7	3	C6	Not Placed	0603
		C11	Not Placed	0603
		C16	Not Placed	0603
8	1	C7	3.9pF	0603
9	2	C13	10pF	0603
		C14	10pF	0603
10	1	C17	0.1µF 50V	0603
11	2	JPR1	0 OHMS	0402
		JPR3	0 OHMS	0402
12	1	JPR2	0 OHMS NP	0402
13	1	L1	680nH	0805
14	1	L3	33nH	0603
15	1	L4	0 OHMS	0603
16	1	R1	(NC)	0402
17	1	R2	100K	0402
18	1	R4	100K	0402
19	1	R7	0 OHMS/ TBD	0603
20	4	S1	SW PUSHBUTTON	SW/PB/KEYBOARD
		S2	SW PUSHBUTTON	SW/PB/KEYBOARD
		S3	SW PUSHBUTTON	SW/PB/KEYBOARD
		S4	SW PUSHBUTTON	SW/PB/KEYBOARD
21	1	U1	MICRF112YMM	10P-MSOP
22	1	U2	MICRF302	10P-MLF
23	1	Y1	13.560MHz	See MICRF112 Data Sheet

Note:

1. Resistor, +/-5%, Vishay or equivalent.
2. Capacitor, ceramic, +/-5% Vishay, Murata or equivalent.
3. Inductors, 0603, 0805 Coilcraft CS series, wire wound, 5% or equivalent.

Package Information

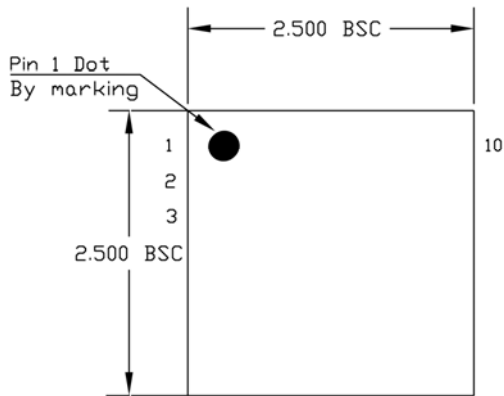

TOP VIEW

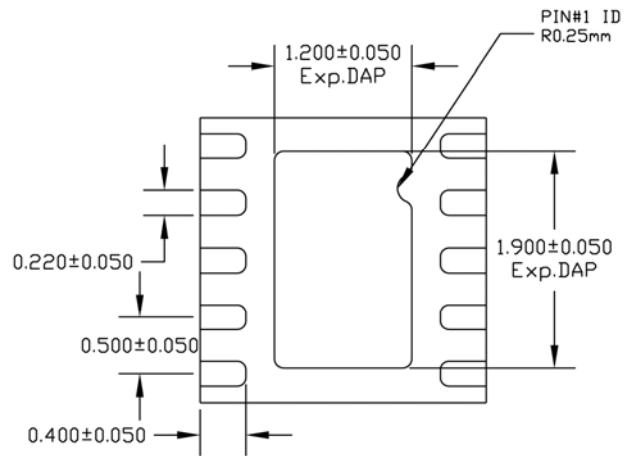

BOTTOM VIEW

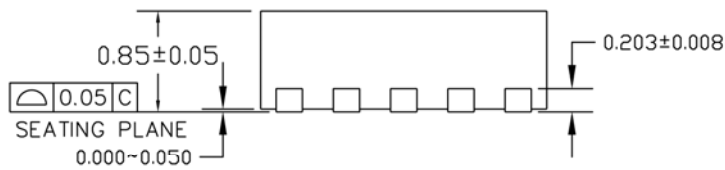

SIDE VIEW

NOTE:

1. ALL DIMENSIONS ARE IN MILLIMETERS.
2. MAX. PACKAGE WARPAGE IS 0.05 mm.
3. MAXIMUM ALLOWABLE BURRS IS 0.076 mm IN ALL DIRECTIONS.
4. PIN #1 ID ON TOP WILL BE LASER MARKED.

MLF2525D-10LD-PD-2-E

10-Pin MLF® (ML)

MICREL, INC. 2180 FORTUNE DRIVE SAN JOSE, CA 95131 USA
 TEL +1 (408) 944-0800 FAX +1 (408) 474-1000 WEB <http://www.micrel.com>

The information furnished by Micrel in this data sheet is believed to be accurate and reliable. However, no responsibility is assumed by Micrel for its use. Micrel reserves the right to change circuitry and specifications at any time without notification to the customer.

Micrel Products are not designed or authorized for use as components in life support appliances, devices or systems where malfunction of a product can reasonably be expected to result in personal injury. Life support devices or systems are devices or systems that (a) are intended for surgical implant into the body or (b) support or sustain life, and whose failure to perform can be reasonably expected to result in a significant injury to the user. A Purchaser's use or sale of Micrel Products for use in life support appliances, devices or systems is a Purchaser's own risk and Purchaser agrees to fully indemnify Micrel for any damages resulting from such use or sale.

© 2008 Micrel, Incorporated.

Mouser Electronics

Authorized Distributor

Click to View Pricing, Inventory, Delivery & Lifecycle Information:

[Micrel:](#)

[MICRF302YML-TR](#)