

USERS MUST ASSURE THEY ARE USING THE CORRECT REVISION.

| REVISIONS | | | | | | |
|-----------|---------|------------------|----------|-----------|----------|------|
| REV | ECO NO. | DESCRIPTION | BY | DATE | APP'D BY | DATE |
| 1 | | ORIGINAL RELEASE | K. KOONS | 3/10/2014 | | |

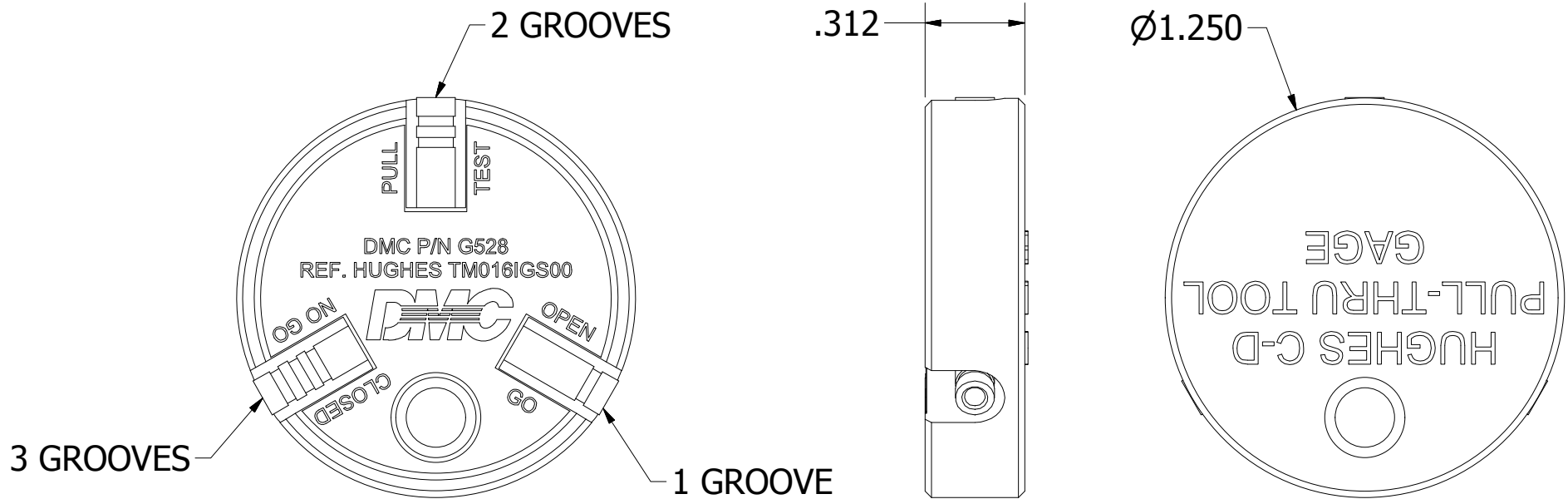

2. REF. HUGHES GAGE P/N 1018991

1. REFER TO DAK1-DS FOR INSTRUCTIONS ON USE.

NOTES:

| MATERIAL | ITEM | PART NO. | QTY. | DESCRIPTION / REMARKS |
|-------------------------------------------------------------------------------------------------------------------------------------------------------------------------------------------------------------------------------------------------------------------------------------------------------------------------------------|---------------------------------------|-------------------------------------------------------------------------------------------------------------------------------------------------------------|---------------------------------|-----------------------------------------------------------------------------------------------------------------------------------------------------|
| N/A | DRN. KIRK C KOONS CHK'D. KCK | DATE 3/10/2014 DATE 3/10/2014 | |  DANIELS MANUFACTURING CORP. ORLANDO, FLORIDA CAGE 11851 |
| RESTRICTED & CONFIDENTIAL CONFIDENTIAL PROPERTY OF DANIELS MANUFACTURING CORP. NOT TO BE DISCLOSED TO OTHERS. REPRODUCTION OR USED FOR ANY OTHER PURPOSE EXCEPT AS AUTHORIZED IN WRITING BY DANIELS MANUFACTURING. MUST BE RETURNED TO DANIELS MANUFACTURING CORP. ON COMPLETION OF ORDER OR PURPOSES FOR WHICH LENT. | HEAT TREAT | APP'D. DATE | TITLE | GAGE, ADJUSTING, ASSEMBLY 16 GAGE SOCKET PULL-THRU TOOL |
| CREATED FROM AN INVENTOR MODEL. CHANGES MUST BE REFLECTED IN THE 3D PART | FINISH | NOTE: THIS DRAWING IS AN OUTLINE DRAWING OF THE RESPECTIVE DMC PART NUMBER INDICATED. ACTUAL DMC PART NUMBER IS DRAWING NUMBER WITHOUT THE "-ENV" SUFFIX | WHERE USED: SIZE A | SCALE 2 : 1 |
| DO NOT SCALE DRAWING | N/A | | CAD P/N G528-ENV | SHEET 1 OF 1 |
| | | | POSTING | DWG. NO. G528-ENV |
| | | | | REV. 1 |