

AVERY DENNISON MARKETING SPECIFICATION

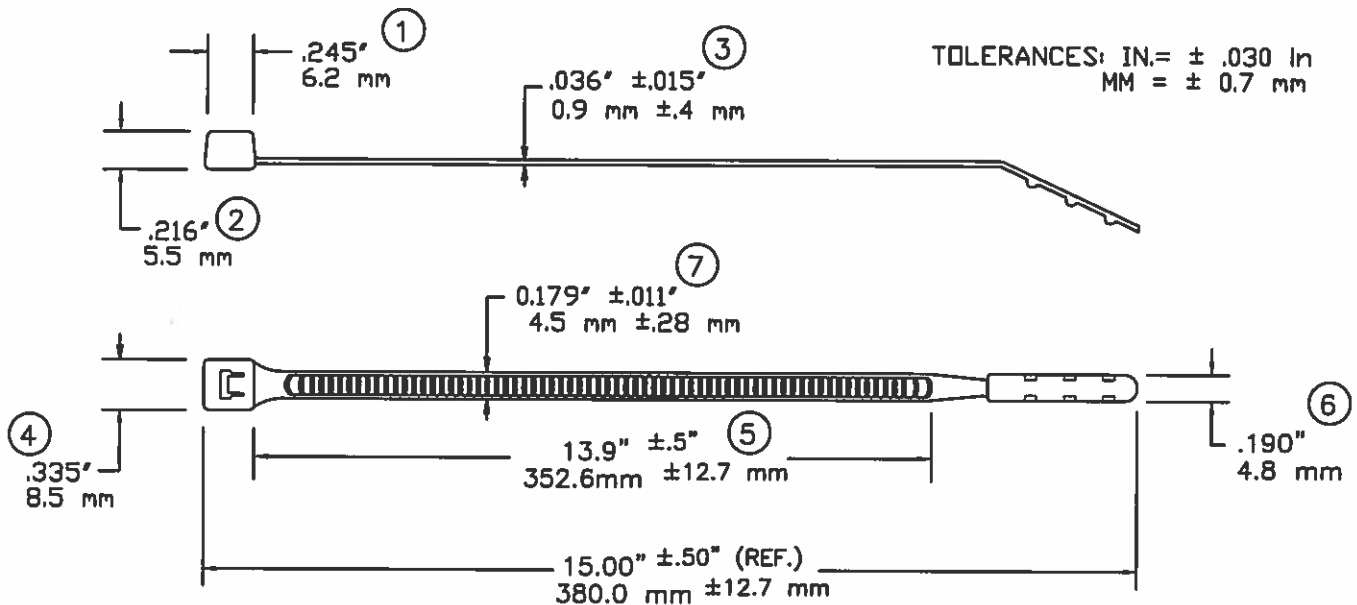

NOT TO SCALE

LOOPED TENSILE STRENGTH:	50 LBSF. / 220 N MINIMUM
MILITARY STANDARD:	MS3367-2-9
MATERIAL:	NYLON 6/6 NATURAL
WEIGHT:	.0497 oz. / 1.46 grams
BUNDLE DIAMETER:	*0.063"/1.59mm to *4.0"/101.6mm
MIN. INSTALLATION TEMP:	32°F (0°C)
OPERATING TEMPERATURE:	-40°F(-40°C) TO 185°F(85°C)
APPLICATION TOOL:	TOOL, HAND ADJUSTABLE, FOR PLASTIC TIE DOWN STRAP, AVERY DENNISON PART NUMBER 12001.
TOOL TENSION SETTING:	6-8
PACKAGED IN:	500/BAG, 5000/CASE



FASTENER DIVISION
FITCHBURG, MA 01420 U.S.A.
TEL. 1-800-225-5913
MA. 978-353-8157

THESE CABLE TIES ARE PLENUM RATED AND HAS A FLAMMABILITY RATING OF V2



DESCRIPTION:

15" SUPER BAR-LOK® CABLE TIE
STANDARD

APPROVAL:

Yvonne Boyle 8/26/15

STOCK NO.

10344-0

REV

E