

NOTES: UNLESS OTHERWISE SPECIFIED

1. CORNERS DRAWN SHARP TO BE R.005 MAXIMUM.
2. EXTERIOR SURFACE TEXTURE TO BE LIGHT EDM FINISH. EQUIVALENT TO MT-11010.
3. INTERIOR SURFACE TEXTURE TO BE: NONE.
4. ALL INSIDE RADII .010R. UNLESS OTHERWISE SPECIFIED.
5. ALL EXTERNAL DIMENSIONS AFFECTED BY THE DRAFT APPLY AT THE LARGE END OF THE FEATURE, AND ALL INTERNAL FEATURES AFFECTED BY THE DRAFT APPLY AT THE SMALL END OF THE FEATURE UNLESS OTHERWISE SPECIFIED.
6. 1 DEGREE DRAFT IN THE DIRECTION OF PULL IS PERMISSIBLE UNLESS OTHERWISE SPECIFIED.
7. THIS ENCLOSURE IS A PRESS FIT ASSEMBLY. FOR PERMANENT CLOSURE: A DROP OF ADHESIVE OR ULTRASONIC WELDING IS REQUIRED.
8. MATERIAL / COLOR: ABS PLASTIC IS STANDARD IN BLACK OR WHITE. CUSTOM MATERIALS AND COLORS ARE AVAILABLE UPON REQUEST FOR QUOTE.
9. PCB SIZES ARE RECOMMENDATIONS ONLY. FINAL SIZES AND VERIFICATION OF IT'S FIT ARE THE SOLE RESPONSIBILITY OF OEM.
10. THE GATE REMNANT FOR THIS ENCLOSURE IS LOCATED IN THIS POSITION TO MINIMIZE THE COSMETIC IMPACT. IT IS HOWEVER VISIBLE AND VARIES IN SIZE / SHAPE. IT IS EASILY REMOVED WITH CLIPPERS. IF YOU WOULD LIKE NEW AGE TO CLIP THIS FOR YOU, PLEASE ASK YOUR SALES REPRESENTATIVE FOR A FREE QUOTE.
11. THIS DRAWING IS BASED ON A SOLID MODEL, AND IS FURTHER DEFINED BY THE SOLID MODEL FILE.
12. ALLOWABLE FLASH: 0.010 MAX.
13. ALL EJECTOR PIN MARKS TO BE WITHIN 0.010" OF FLUSH, PROTRUDING OR BELOW FLUSH.
14. TRIM GATE WITHIN 0.015" OF FLUSH.

CONFIGURATION LEGEND

- Tx = BOTH COVER AND BASE ARE TALL
- Fx = BOTH COVER AND BASE ARE SHORT (FLAT)
- Cx = ONLY THE COVER IS TALL (BASE IS FLAT)
- Bx = ONLY THE BASE IS TALL (COVER IS FLAT)
- xs = STANDARD ENCLOSURE (NO USB OPENING)
- xu = ENCLOSURE WITH MOLDED TYPE A USB OPENING

090604(xx) CONFIGURATIONS

	-TS	-TU	-FS	-FU	-CS	-CU	-BS	-BU
090604 COVER			1				1	
090604 COVER w/ TYPE A USB				1				1
090606 TALL COVER	1				1			
090606 TALL COVER w/ TYPE A USB		1				1		
090604 BASE			1		1			
090604 BASE w/ TYPE A USB				1		1		
090606 TALL BASE	1						1	
090606 TALL BASE w/ TYPE A USB		1						1

ITEM	DESCRIPTION	MATERIAL	COLOR	QTY.
5	090604 PCB - REFERENCE	.062" THICK	CUSTOMER SUPPLIED	1
4	090606U COVER - STANDARD	ABS	BLACK or WHITE	1
3	090606U BASE - STANDARD	ABS	BLACK or WHITE	1
2	090604U COVER - STANDARD	ABS	BLACK or WHITE	1
1	090604U BASE - STANDARD	ABS	BLACK or WHITE	1

BILL OF MATERIALS

R E V I S I O N					
REV.	DRAWN BY	ECO No	DESCRIPTION	DATE	APPROVED
A	M BOYER	DR XXX	PRELIMINARY RELEASE	17-Sep-11	D.C.
B	M BOYER		ADD THICKER COMPONENTS	09-May-12	D.C.
C	M BOYER		ADD SECOND PRESS POST	15-May-12	D.C.
D	M BOYER		REDUCE WIDTH AND THICKNESS	16-May-12	D.C.
E	M BOYER		ADD VIEWS AND NOTES	06-Feb-13	

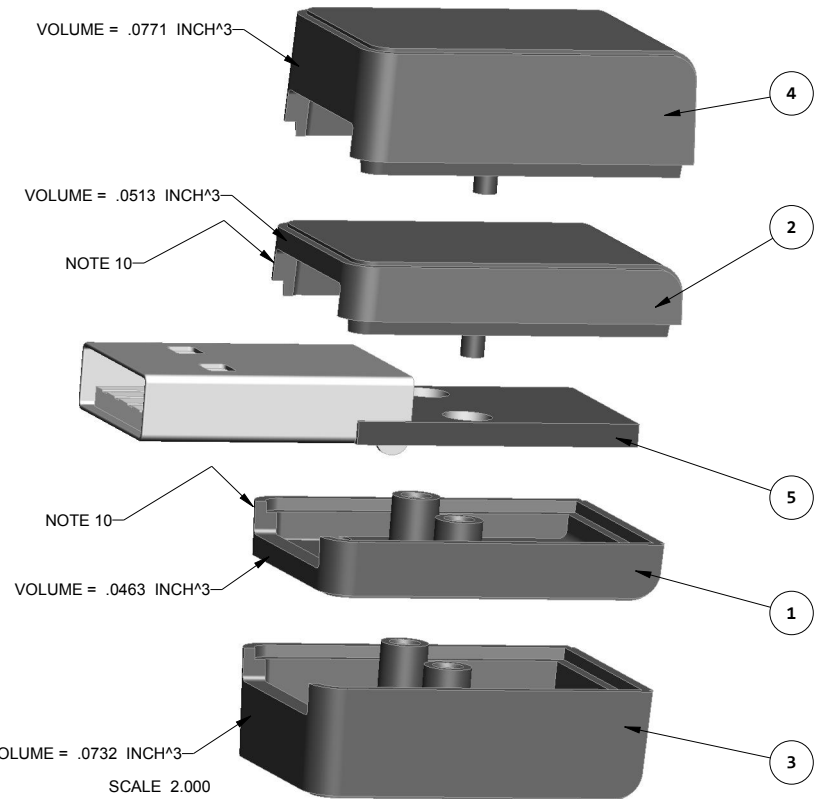
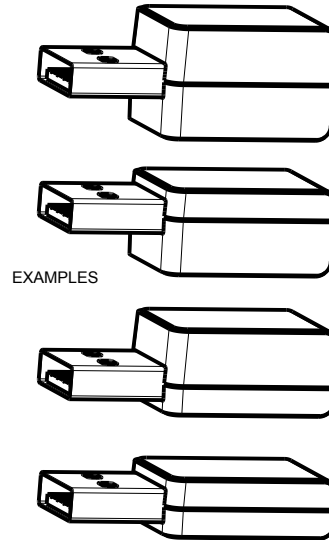

<p>THIRD ANGLE PROJECTION</p> <p>DO NOT SCALE DRAWING</p>	<p>TOLERANCES: UNLESS OTHERWISE SPECIFIED DIMENSIONS ARE IN U.S. INCHES.</p> <p>X.XX = .015 X.XXXX = .001</p> <p>X.XXX = .010 X.X" = 1"</p>	<p>NEW AGE ENCLOSURES</p> <p>4330 Santa Fe Road San Luis Obispo, CA. 93401</p> <p>ph. (805) 595-1310 fax (805) 595-1024</p> <p>www.newageenclosures.com</p>	
	<p>Customer's Part No: 090604</p>		
<p>APPROVAL</p> <p>CHECK</p> <p>ENG.</p> <p>SCALE</p> <p>DRAWN BY</p>	<p>BY</p> <p>DATE</p> <p>AS NOTED</p> <p>17-Sep-11</p>	<p>EXPAND. USB - STANDARD</p> <p>090604XX-XXX</p>	<p>SIZE</p> <p>A</p>
<p>DRAWING NAME</p> <p>090604_RE</p>		<p>SHEET</p> <p>1 OF 7</p>	<p>REV.DOC</p> <p>E</p>

090604FU ASSEMBLY

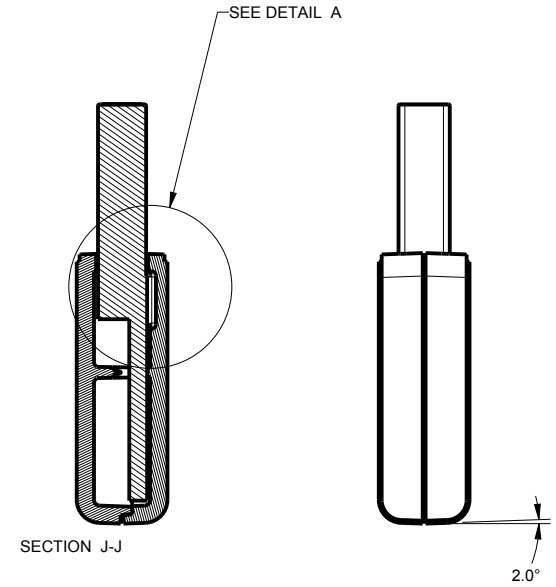
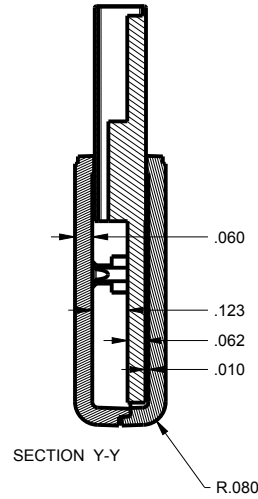
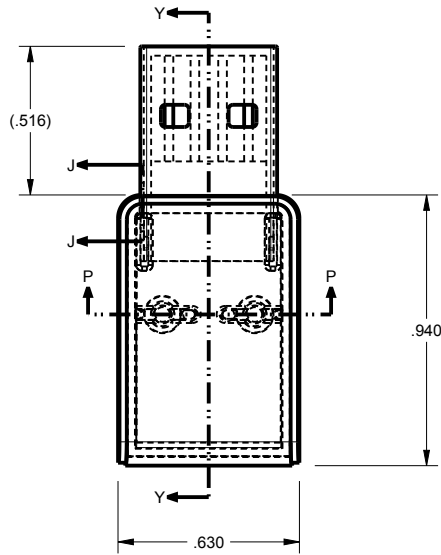
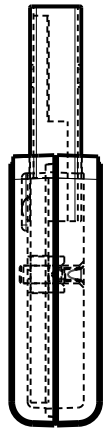
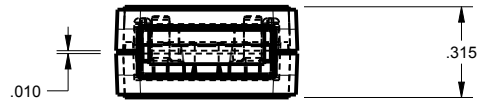

SCALE 1.500

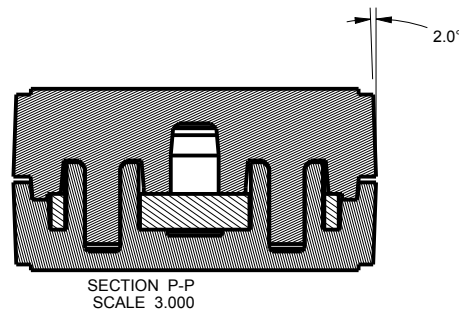
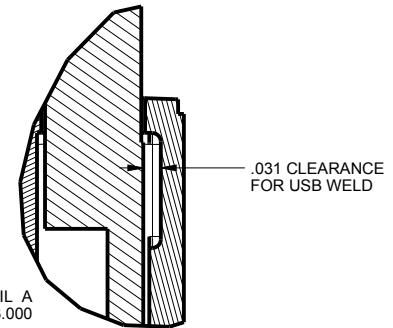
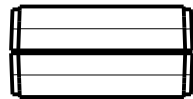

TOLERANCES: UNLESS OTHERWISE SPECIFIED
DIMENSIONS ARE IN U.S. INCHES.
X.XX = .015 X.XXXX = .001
X.XXX = .010 X.X° = 1°

NEW AGE ENCLOSURES

Customer's Part No: 090604

APPROVAL	BY	DATE
CHECK		
ENG.		
SCALE	AS NOTED	

DRAWN BY
M BOYER 17-Sep-11

NEW AGE ENCLOSURES

4330 Santa Fe Road San Luis Obispo, CA. 93401
ph. (805) 595-1310 fax (805) 595-1024
www.newageenclosures.com

EXPAND. USB - STANDARD
090604XX-XXX

SIZE A	DRAWING NAME 090604_RE	SHEET 2 OF 7	REV.DOC E
-----------	---------------------------	-----------------	--------------

090604TU ASSEMBLY

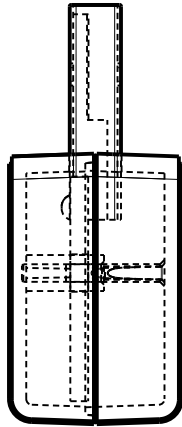
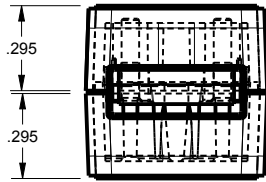

SCALE 1.500

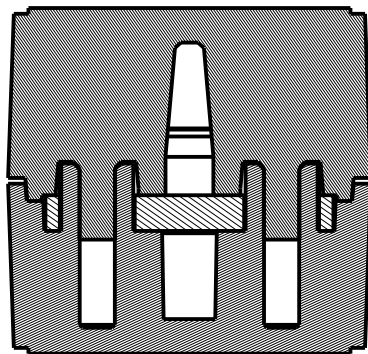
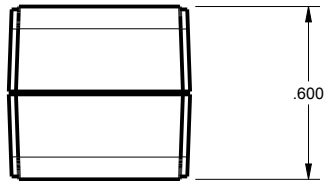
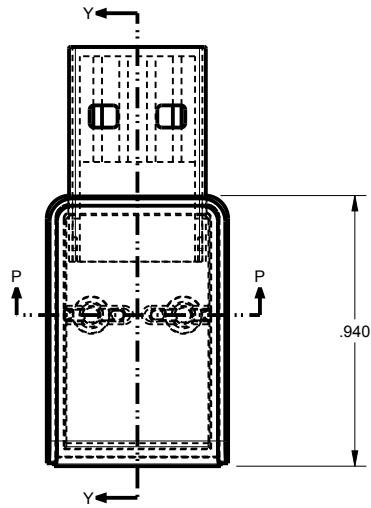

SECTION P-P
SCALE 3.000

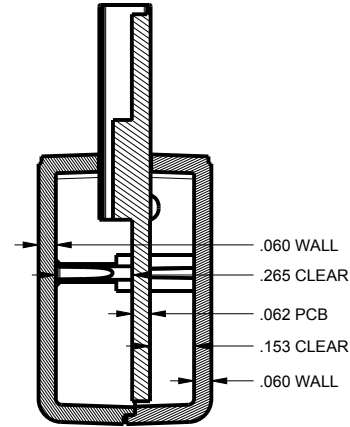

SECTION Y-Y

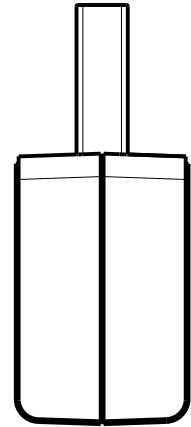

TOLERANCES: UNLESS OTHERWISE SPECIFIED
DIMENSIONS ARE IN U.S. INCHES.
X.XX = .015 X.XXXX = .001
X.XXX = .010 X.X° = 1°

NEW AGE ENCLOSURES

Customer's Part No: 090604

APPROVAL BY DATE

CHECK

ENG.

SCALE AS NOTED

DRAWN BY M BOYER 17-Sep-11

NEW AGE ENCLOSURES

4330 Santa Fe Road San Luis Obispo, CA. 93401
ph. (805) 595-1310 fax (805) 595-1024

www.newageenclosures.com

EXPAND. USB - STANDARD
090604XX-XXX

SIZE A DRAWING NAME 090604_RE

SHEET 3 OF 7 REV.DOC E

090604 COVER

OPTIONAL TYPE A
USB OPENING

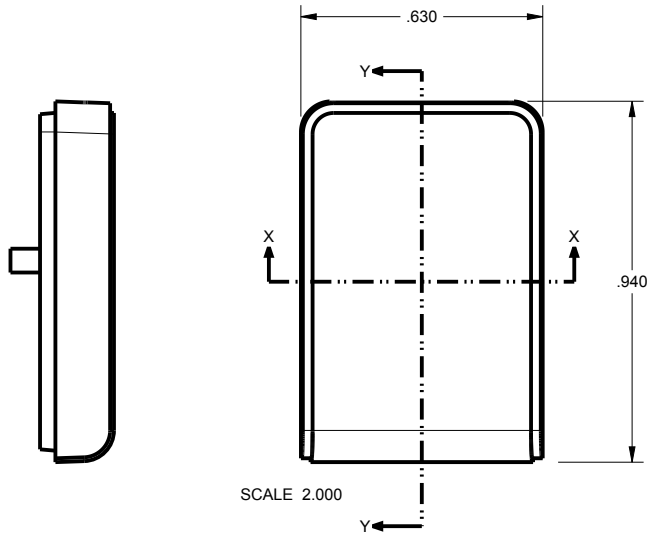
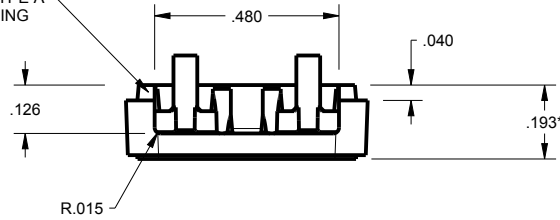

SCALE 2.000

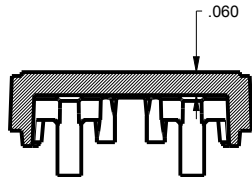

SECTION X-X

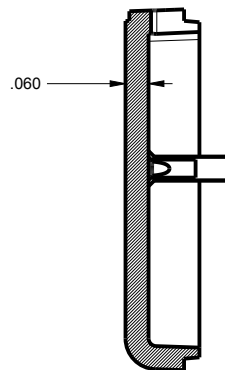
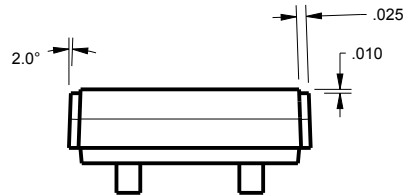

SECTION Y-Y

.035 +1°
DRAFT/SIDE

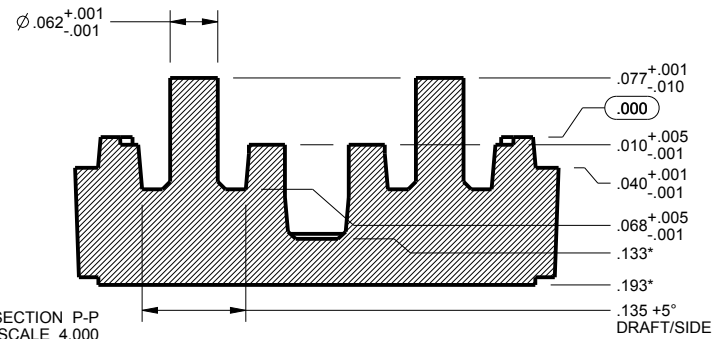
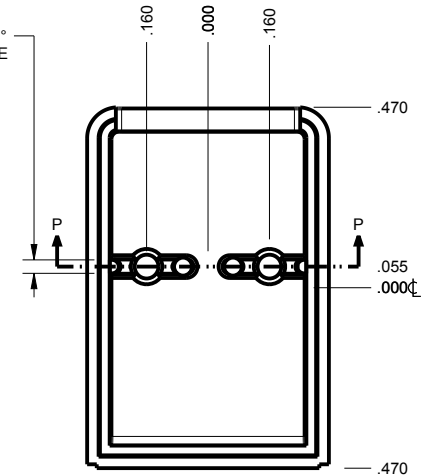

SECTION P-P
SCALE 4.000

TOLERANCES: UNLESS OTHERWISE SPECIFIED
DIMENSIONS ARE IN U.S. INCHES.

X.XX = .015 X.XXXX = .001
X.XXX = .010 X.X° = 1°

NEW AGE ENCLOSURES

Customer's Part No: 090604

APPROVAL	BY	DATE
CHECK		
ENG.		
SCALE	AS NOTED	

DRAWN BY
M BOYER 17-Sep-11

NEW AGE ENCLOSURES

4330 Santa Fe Road San Luis Obispo, CA. 93401
ph. (805) 595-1310 fax (805) 595-1024

www.newageenclosures.com

EXPAND. USB - STANDARD 090604XX-XXX

SIZE A	DRAWING NAME 090604_RE	SHEET 4 OF 7	REV.DOC E
-----------	---------------------------	-----------------	--------------

* = ADD .100" TO DIMENSION FOR 090606 (FAT) COVER.

090604 BASE

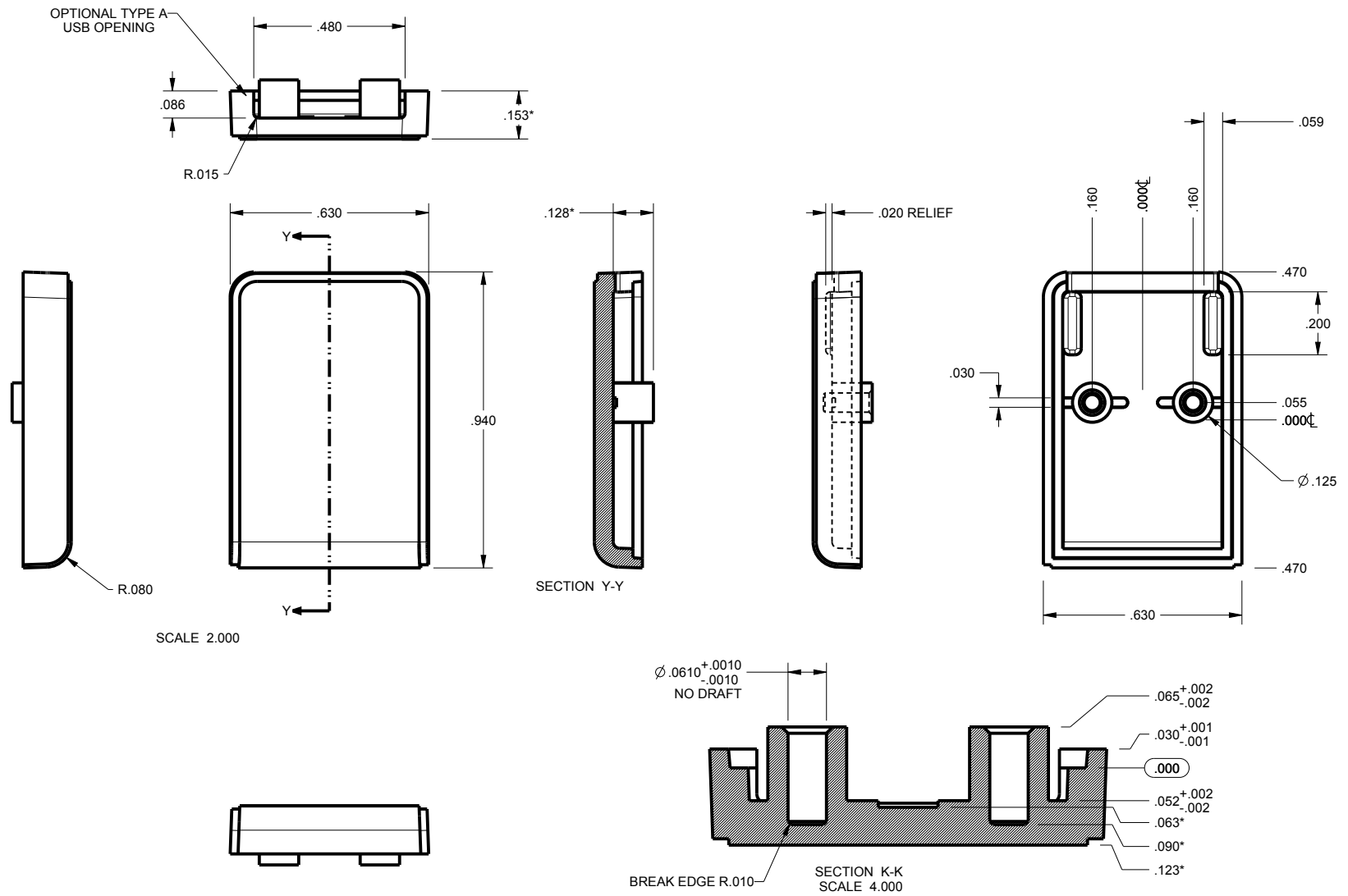

* = ADD .100" TO DIMENSION FOR 090606 (FAT) BASE.

TOLERANCES: UNLESS OTHERWISE SPECIFIED
DIMENSIONS ARE IN U.S. INCHES.
X.XX = .015 X.XXXX = .001
X.XXX = .010 X.X° = 1°

NEW AGE ENCLOSURES

Customer's Part No: 090604

APPROVAL	BY	DATE
CHECK		
ENG.		
SCALE	AS NOTED	

DRAWN BY	17-Sep-11
M BOYER	

NEW AGE ENCLOSURES

4330 Santa Fe Road San Luis Obispo, CA. 93401
ph. (805) 595-1310 fax (805) 595-1024
www.newageenclosures.com

EXPAND. USB - STANDARD
090604XX-XXX

SIZE	DRAWING NAME	SHEET	REV.DOC
A	090604_RE	5 OF 7	E

090604 PCB CUSTOMER SUPPLIED

PCB SIZES ARE RECOMMENDATIONS ONLY. FINAL
SIZES AND VERIFICATION OF IT'S FIT ARE THE
SOLE RESPONSIBILITY OF THE OEM.

REFERENCE ONLY
USB PLUG CONNECTOR
ACON ADVANCED CONNECTEK INC.
PN. C-UAR70-00-00

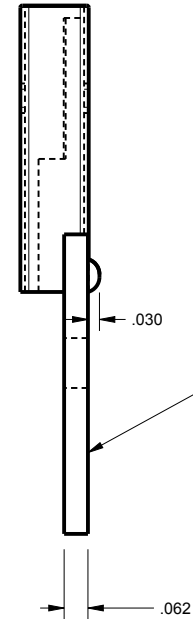
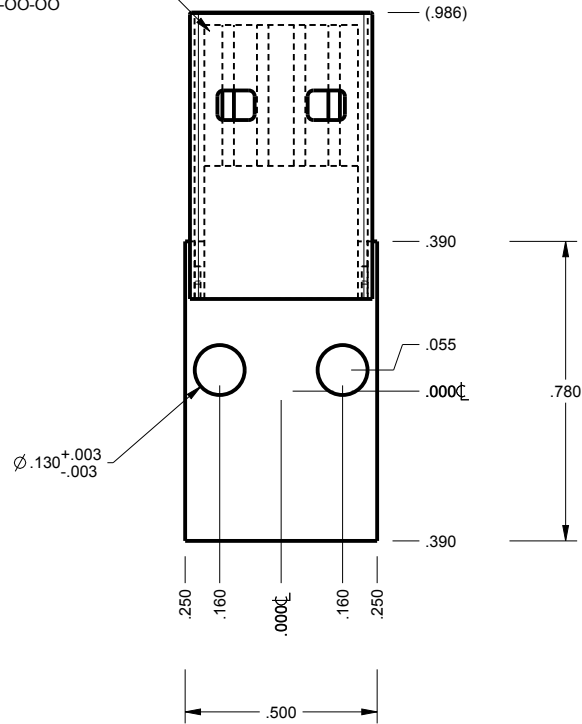

THE ENCLOSURE CAN ACCOMODATE
VARIOUS PCB THICKNESSES
BY REPLACING MOLD INSERTS
AT MINIMAL COST.
PLEASE CONTACT YOUR
SALES REPRESENTATIVE FOR
MORE INFORMATION.

SCALE 2.000

TOLERANCES: UNLESS OTHERWISE SPECIFIED DIMENSIONS ARE IN U.S. INCHES.		NEW AGE ENCLOSURES		
X.XX = .015 X.XXXX = .001 X.XXX = .010 X.X° = 1°				
NEW AGE ENCLOSURES		4330 Santa Fe Road San Luis Obispo, CA. 93401 ph. (805) 595-1310 fax (805) 595-1024 www.newageenclosures.com		
Customer's Part No: 090604				
APPROVAL	BY	DATE	EXPAND. USB - STANDARD 090604XX-XXX	
CHECK				
ENG.				
SCALE	AS NOTED			
DRAWN BY	SIZE	DRAWING NAME	SHEET	REV.DOC
M BOYER	A	090604_RE	6 OF 7	E

2nd OPERATION DETAILS

NEW AGE ENCLOSURES DELIVERS YOUR ENCLOSURE MARKET-READY WITH IN-HOUSE
CNC MACHINING, PAD PRINTING, ASSEMBLY, AND FULFILLMENT.
ALL SURFACES AND AREAS ARE AVAILABLE FOR CNC ALTERATION BY NEW AGE ENCLOSURES
CALL (805) 595-1310 FOR PRICING AND SCHEDULE.
THE INSIDE RADIUS OF ANY MACHINED FEATURES SHOULD BE NO SMALLER THAN .031"

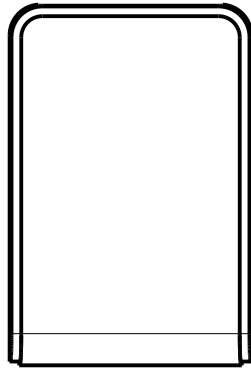
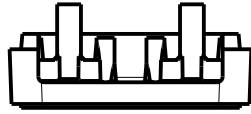

090604 COVER
SCALE 2.000

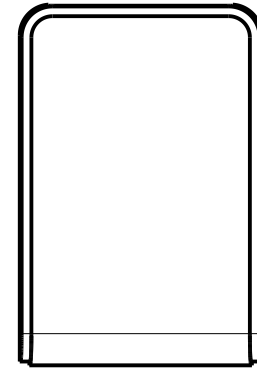
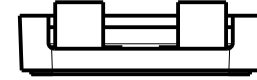
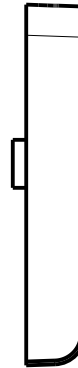

090604 BASE
SCALE 2.000

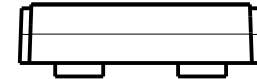
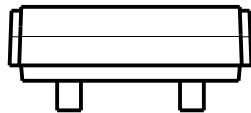

PXX-090604XX-XXX COVER - ABS, BLACK

STEP NO	DESCRIPTION	CUTTER	FIXTURE	ORIENTATION	PROGRAM
1	-	T2 = .062" EM	-	-	-

PXX-090604XX-XXX COVER - ABS, BLACK

STEP NO	DESCRIPTION	INK COLOR	CLICHE DESCRIPTION	CLICHE No.
2	PAD PRINT			CL1010

TOLERANCES: UNLESS OTHERWISE SPECIFIED
DIMENSIONS ARE IN U.S. INCHES.
X.XX = .015 X.XXXX = .001
X.XXX = .010 XX° = 1°

NEW AGE ENCLOSURES
Customer's Part No: 090604

APPROVAL	BY	DATE
CHECK		
ENG.		
SCALE	AS NOTED	
DRAWN BY	17-Sep-11	
M BOYER		

NEW AGE ENCLOSURES

4330 Santa Fe Road San Luis Obispo, CA. 93401
ph. (805) 595-1310 fax (805) 595-1024
www.newageenclosures.com

EXPAND. USB - STANDARD 090604XX-XXX		SIZE	DRAWING NAME	SHEET	REV.DOC
		A	090604_RE	7 OF 7	E