

THIS DOCUMENT IS THE PROPERTY OF
KEYSTONE ELECTRONICS CORP. AND
SHALL NOT BE REPRODUCED, DISTRIBUTED
OR USED AS A BASIS FOR MANUFACTURE
WITHOUT PRIOR WRITTEN PERMISSION
FROM KEYSTONE ELECTRONICS CORP.

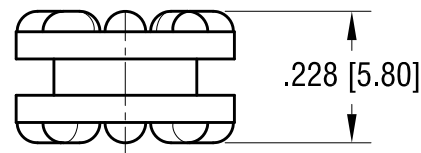
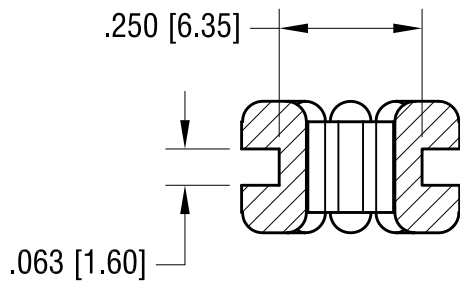
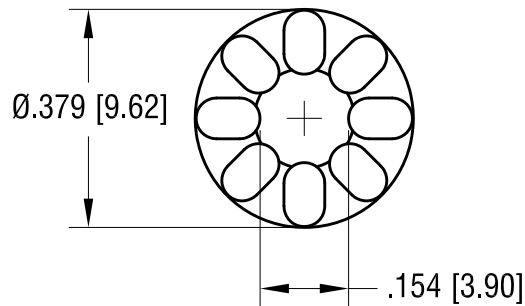
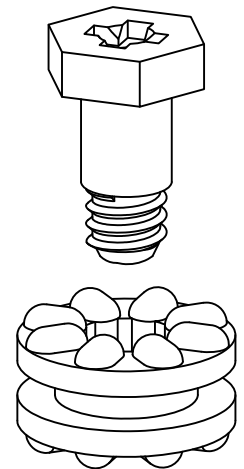

NOTE:

1. GROMMET: MAT'L- THERMOPLASTIC RUBBER
(BLUE COLOR)
2. SHOULDER SCREW P/N 2510 (SUPPLIED UNASSEMBLED)
.250 [6.35] HEX x 6-32 THREAD x .134 [3.40] L
MAT'L-STELL
FINISH- NICKEL PLATE

KEYSTONE ELECTRONICS CORP.

www.keyelco.com • ASTORIA, N.Y. 11105-2017 • Tel (718) 956-8900

PART NAME

ANTI-VIBRATE GROMMET ASSEMBLY

MATERIAL

AS NOTED

FINISH

AS NOTED

DRN BY

NT

DATE

12.14.10

APP'D

LN

SCALE

3X

8.05.11 CHANGE AS PER ECN 11-101

A

TOLERANCES

INCH [MM]

DECIMAL ± .005 [± 0.13]

ANGULAR ± 1°

UNLESS OTHERWISE SPECIFIED

CODE

C

DWG NO.

766

DATE

DESCRIPTION

REV.