

Features

- Low loss
- Flat Low Ripple

Description

Surface mount, silver (Ag) coated ceramic duplexer. Developed for use in DCS infrastructure applications.

Weight: 3.0 grams typical

Material: Filter is composed of a ceramic block plated with Ag and a shield made of nickel silver plated steel.

Filter complies with RoHS standards.

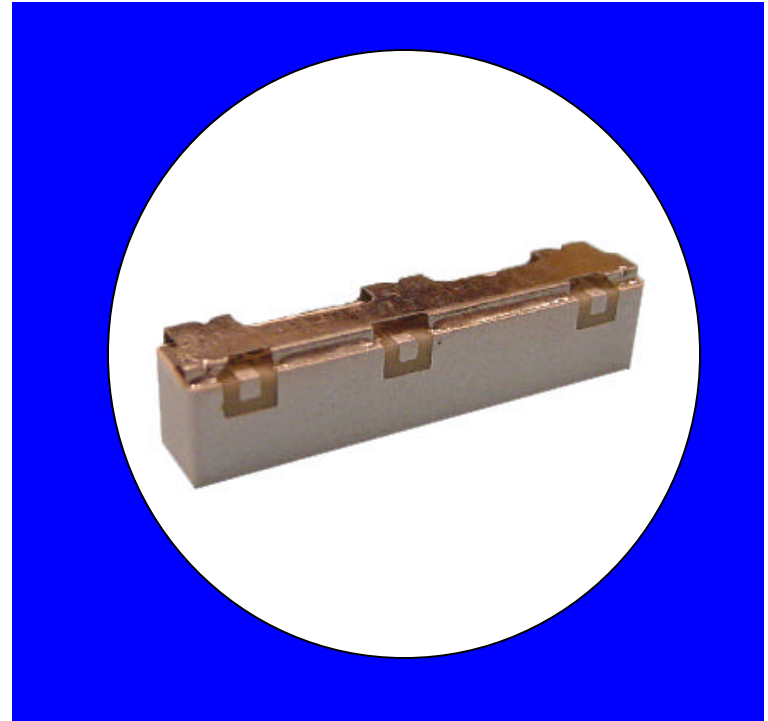

Electrical Specifications

Parameter	Frequency MHz	Typical @ 25°C	Specification @ 25°C	Spec over -40°C to +85°C
Low Band Response (S21)				
Passband Iloss	1710 - 1785	-2.80	-3.20	-3.40
Passband Ripple	1710 - 1785	1.70	2.20	2.30
Passband Return Loss @ Port 2	1710 - 1785	-13.50	-10.00	-10.00
Passband Return Loss @ Ant	1710 - 1785	-13.50	-10.00	-10.00
Attenuation	1805 - 1880	-42.50	-40.00	-40.00
High Band Response (S13)				
Passband Iloss	1805 - 1880	-2.60	-3.00	-3.20
Passband Ripple	1805 - 1880	1.70	2.20	2.30
Passband Return Loss @ Port 3	1805 - 1880	-13.50	-10.00	-10.00
Passband Return Loss @ Ant	1805 - 1880	-13.50	-10.00	-10.00
Attenuation	1710 - 1785	-42.50	-40.00	-40.00
Isolation (S23)				
Rejection @ Low Band	1710 - 1785	-44.50	-42.00	-42.00
Rejection @ High Band	1805 - 1880	-46.00	-42.00	-42.00
Power into any port		3 Watt max		

Note: Supplier shall test each filter to the critical electrical specifications of the above table. Any subsequent audits may deviate from in value due to measurement repeatability among different test systems. Such deviations shall not exceed the following limits:

Specification Allowance	
Insertion Loss	0.1 dB
Return Loss	1.0 dB
Stopbands	1.0 dB

*This product is covered by one or more of the following U.S. and foreign patents including: US 4,692,726;US 4,742,562; US 4,800,348;US 4,829,274;US 5,146,193;EP 0573597;DE 0573597;FR 0573597;JP 508149/92;KR 142171;US 5,162,760;US 5,218,329;US 5,250,916;US 5,327,109;US 5,488,335;CA 2114029;FR 9306297;GB 2273393;JP 3205337;KR 115113;CN 93106228.4;US 5,512,866;EP 0706719;DE 0706719;FR 0706719;GB 0706719;CN 95190359.4;US 5,602,518;US 5,721,520;US 5,745,018;EP 0910875;DE 0910875;DK 0910875;FR 0910875;GB 0910875;IE 0910875;JP 505182/98;KR 10-323013;US 5,994,978;US 6,462,629;CN 00810420.4;US 6,559,735;US 6,650,202;US 6,834,429. Other US and foreign patents pending.

CTS Corporation 2006 reserves all copyrights in the layout, design and configuration of the patterns on this product.

Mechanical Drawing

Rev 2 – Origin Date: January 2, 2006 – Revision Date: December 13, 2006

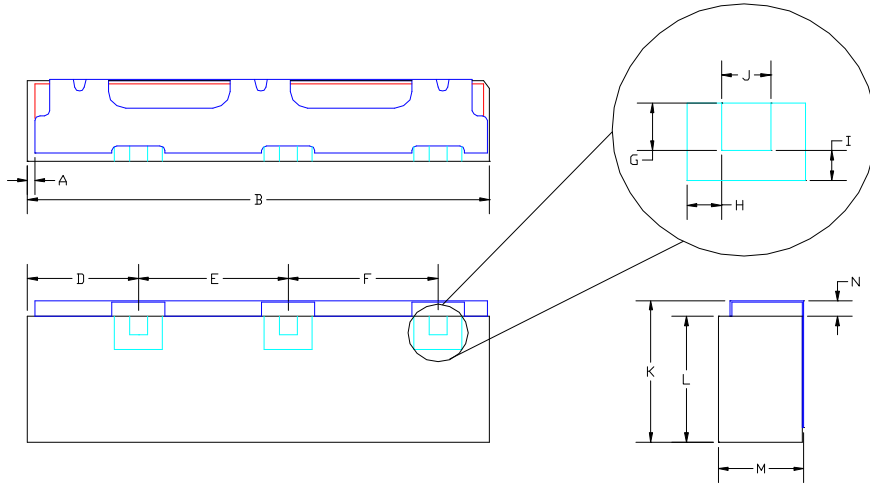

Dim	Nominal (mm)	Tolerance (mm) +/- or max
A	0.25	0.25
B	24.04	max
D	2.72	0.25
E	7.44	0.13
F	10.52	0.13
G	1.02	0.13
H	0.79	0.13
I	0.79	0.13
J	0.89	0.13
K	7.00	max
L	6.00	max
M	4.60	max
N	0.84	0.13

Electrical response

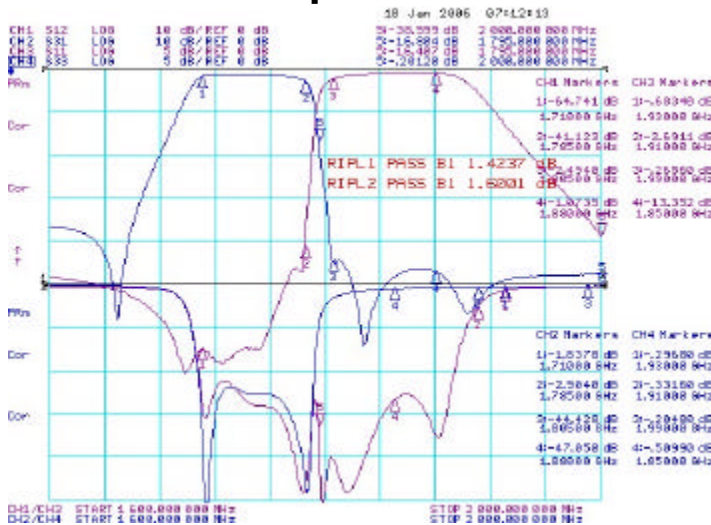

PCB Layout

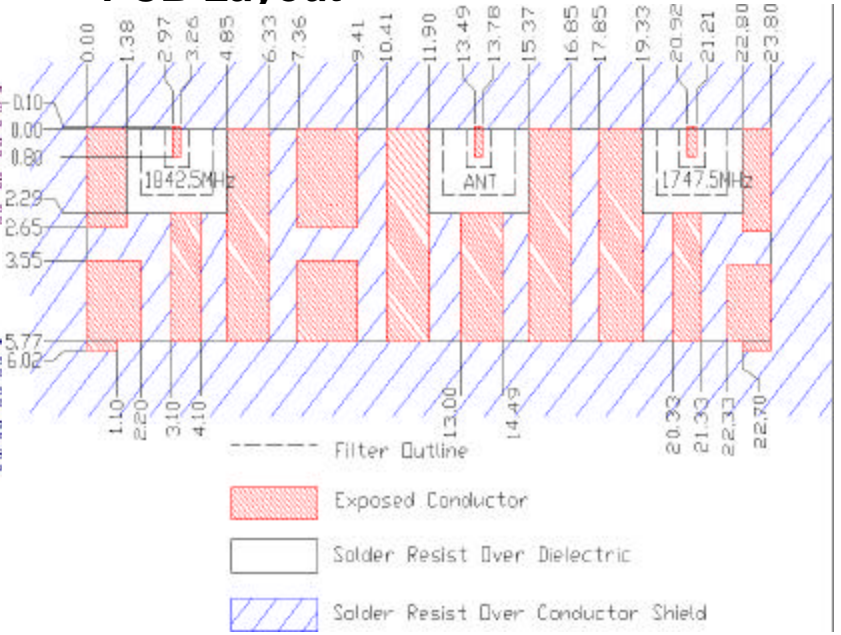

Packaging and Marking

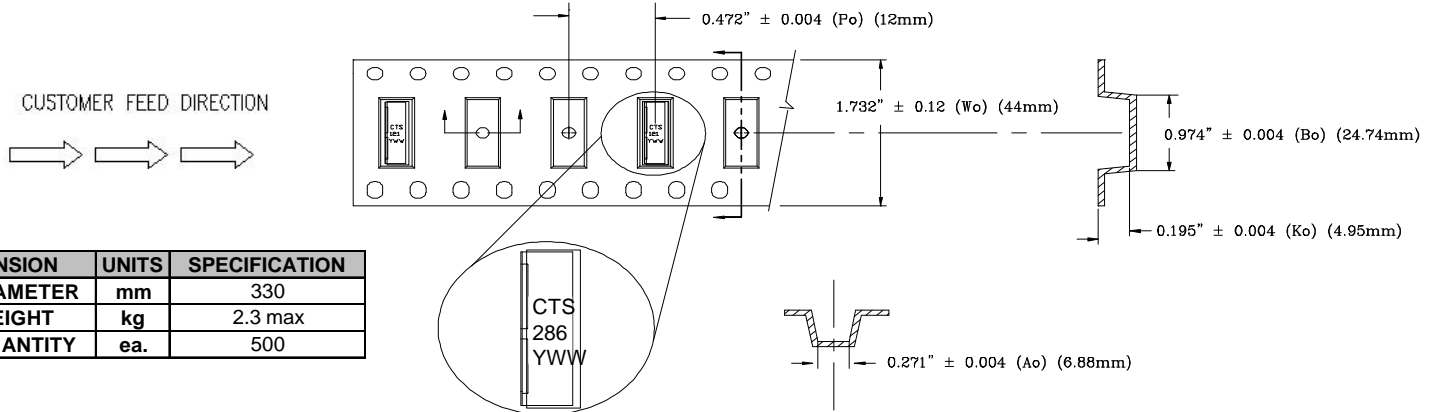

DIMENSION	UNITS	SPECIFICATION
REEL DIAMETER	mm	330
REEL WEIGHT	kg	2.3 max
REEL QUANTITY	ea.	500