

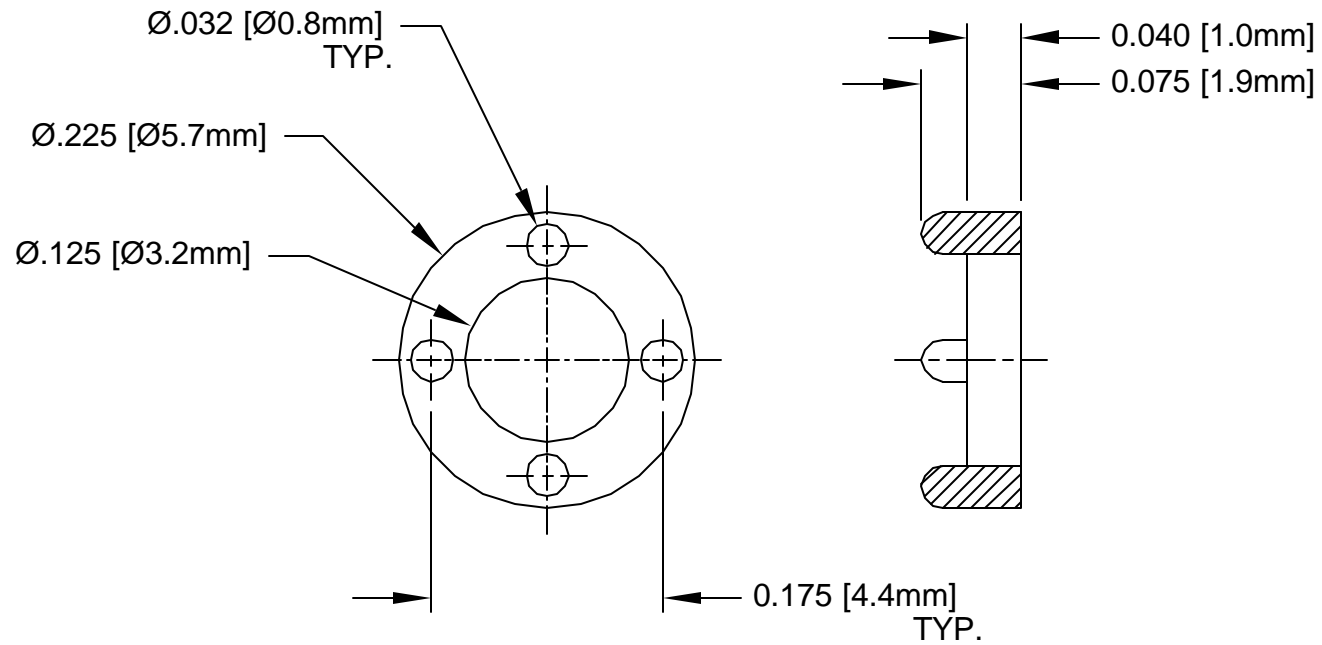

REV.	DESCRIPTION	DATE	APPROVED
A	Engineering Release	04/10/03	M. C.
B	Engineering Update w/o Changes	01/28/05	M. C.



2. MATERIAL: NYLON 6/6, 94V-2, WHITE. BIVAR MATERIAL CODE 04-WE.
 BASF ULTRAMID NYLON 6/6 A3K WHITE.

1. GENERAL SPECIFICATIONS: BIVAR MOLDED COMPONENT SPECIFICATION BV00-E101.

STANDARD TOLERANCE (UNLESS OTHERWISE SPECIFIED)		 4 THOMAS, IRVINE, CA. 92618 TEL: (949) 951-8808 FAX: (949) 951-3974	
DECIMALS	ANGULAR	 TITLE: PERM-O-PAD LED MOUNT	
.X ±.1	X° ± 1°		
.XX ±.01			
.XXX ±.005		PART NO: 103-080	REVISION: B
DESIGNED: David Green	DATE: 04/10/03	CAGE CODE : 32559 SHEET # 1 OF 1	
CHECKED: M. Chen	DATE: 04/10/03	CAD GENERATED DOCUMENT. DO NOT MEASURE DRAWING.	