

IEC Socket-Outlet 400 VDC, Snap-in Mounting, Front Side, Quick-connect or PCB Terminals



GS21 socket-outlet with snap-in mounting for 400 VDC systems up to 2.6 kW

Standard Sheet 1



See below:

[Approvals and Compliances](#)

### Description

- Panel mount :  
Snap-in version from front side
- Socket-Outlet , Protection class I
- Quick Connect or PCB Terminals

### Unique Selling Proposition

- Standard form acc. to IEC TS 62735-1
- Hot plug rated for disconnecting under load up to 2.6 kW
- Ideal for compact PDU applications with an operating temperature up to 105 °C
- Compatible with cord retention system

### Other versions on request

- Other panel thickness
- Other terminals
- Color coding in grey or white

### Weblinks

[pdf data sheet](#), [html datasheet](#), [General Product Information](#), [Approvals](#), [Distributor-Stock-Check](#), [Accessories](#), [Detailed request for product](#), [Landing Page](#), [Video](#)

### Technical Data

|                                 |  |
|---------------------------------|--|
| Ratings IEC                     | 6.5 - 8.8A / 400 - 294VDC<br>max. 2.6 kW power                   |
| Dielectric Strength             | > 3kVDC between + and -<br>> 3kVDC between +/- and PE<br>(1 min) |
| Allowable Operation Temperature | -5°C to 105°C  |
| IP-Protection                   | from front side IP20 acc. to IEC 60529                           |
| Terminal                        | Quick Connect or PCB Terminals                                   |
| Panel Thickness S               | Snap-in: 1.5/2.0 mm  |
| Material: Housing               | Thermoplastic, black, UL 94V-0                                   |

|                         |   |
|-------------------------|---|
| Appliance inlet/-outlet | Standard Sheet 1 acc. to IEC TS 62735-1<br>Protection Class I , ± 200 VDC |
|-------------------------|---|

### Approvals and Compliances

Detailed information on product approvals, code requirements, usage instructions and detailed test conditions can be looked up in [Details about Approvals](#)

SCHURTER products are designed for use in industrial environments. They have approvals from independent testing bodies according to national and international standards. Products with specific characteristics and requirements such as required in the automotive sector according to IATF 16949, medical technology according to ISO 13485 or in the aerospace industry can be offered exclusively with customer-specific, individual agreements by SCHURTER.

### Approvals



The approval mark is used by the testing authorities to certify compliance with the safety requirements placed on electronic products.

Approval Reference Type: GS21

| Approval Logo | Certificates                  | Certification Body | Description                      |
|---------------|-------------------------------|--------------------|----------------------------------|
|               | <a href="#">VDE Approvals</a> | VDE                | VDE Certificate Number: 40051170 |
|               | <a href="#">UL Approvals</a>  | UL                 | UL File Number: E502317          |

## Product standards

Product standards that are referenced

| Organization   | Design                | Standard        | Description   |
|--|-----------------------|-----------------|---|
|  | Designed according to | IEC TS 62735-1  | Appliance couplers for household and similar general purposes   |
|  | Designed according to | IEC TS 62735-1  | Appliance couplers for household and similar general purposes   |
|  | Designed according to | UL Subject 2695 | Outline for DC rated Attachment Plugs and Outlet Devices for ICT Equipment installed in restricted access locations |





## Application standards

Application standards where the product can be used

| Organization   | Design                         | Standard       | Description  |
|--|--------------------------------|----------------|--|
|  | Designed for applications acc. | IEC/UL 62368-1 | IEC 62368-1 includes the basic requirements for safety of audio, video, information technology and office equipment. |

## Compliances

The product complies with following Guide Lines

| Identification   | Details      | Initiator   | Description   |
|--|--------------|-------------|---|
|  | RoHS         | SCHURTER AG | Directive RoHS 2011/65/EU, Amendment (EU) 2015/863  |
|  | China RoHS   | SCHURTER AG | The law SJ / T 11363-2006 (China RoHS) has been in force since 1 March 2007. It is similar to the EU directive RoHS.  |
|  | Halogen Free | SCHURTER AG | SCHURTER strives to offer our customers halogen free products.  |
|  | REACH        | SCHURTER AG | On 1 June 2007, Regulation (EC) No 1907/2006 on the Registration, Evaluation, Authorization and Restriction of Chemicals 1 (abbreviated as "REACH") entered into force. |

## Dimensions [mm]

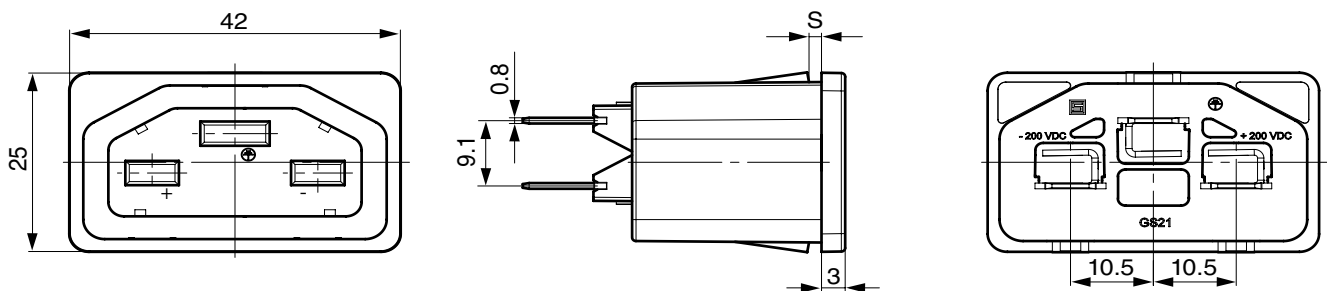

Quick-connect terminals

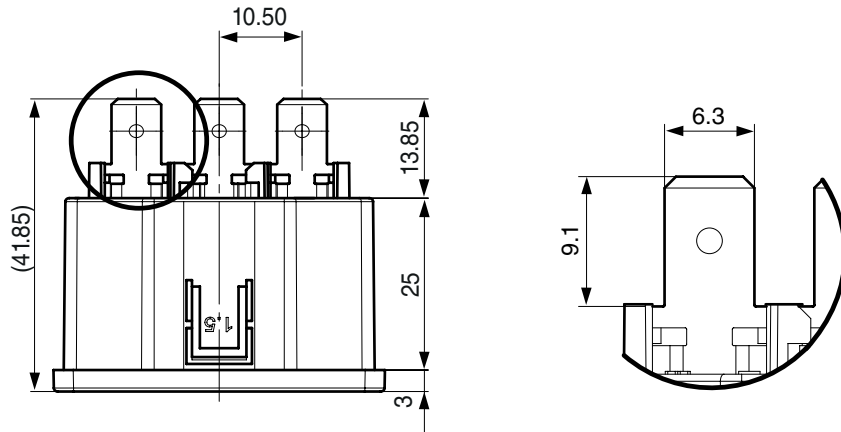

Solder terminals for PCB

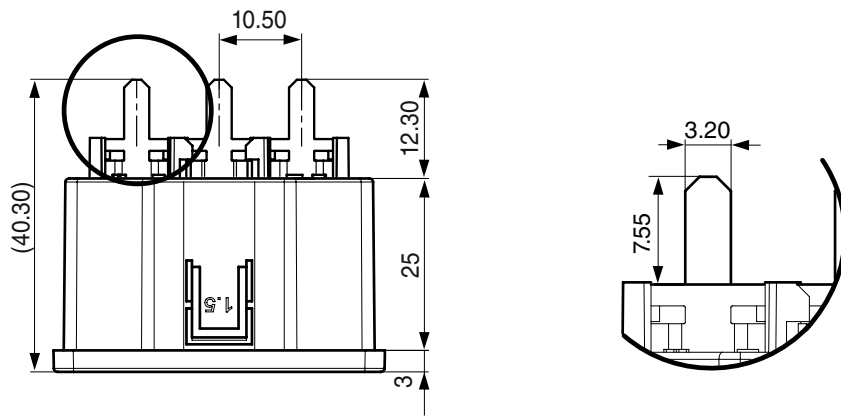

PCB Terminal with shoulder

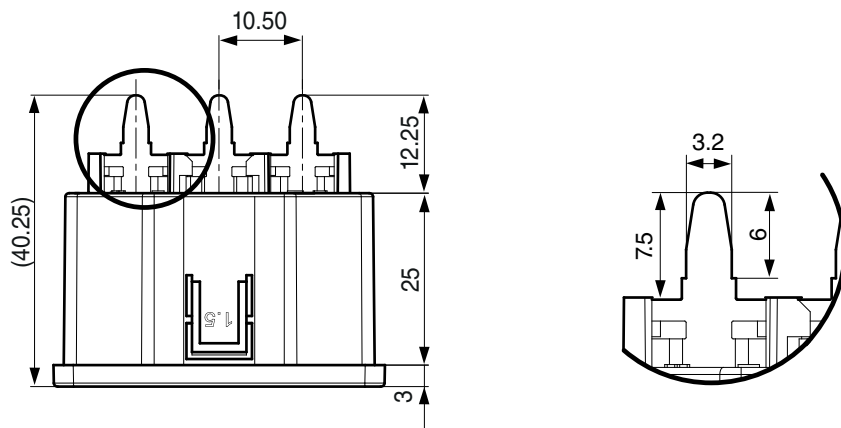

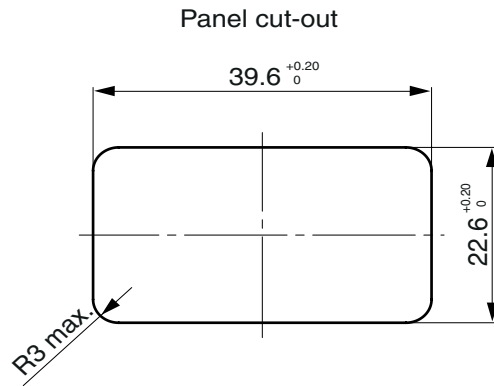

All Variants

| Panel mounting | Panel Thickness s [mm] | Terminal                             | IP Protection Class Front Side | Order Number |
|----------------|------------------------|--------------------------------------|--------------------------------|--------------|
| Snap-in        | 1.5                    | PCB terminals                        | IP20                           | 3-104-045    |
| Snap-in        | 2.0                    | PCB terminals                        | IP20                           | 3-104-046    |
| Snap-in        | 1.5                    | PCB terminals with shoulder          | IP20                           | 3-104-047    |
| Snap-in        | 2.0                    | PCB terminals with shoulder          | IP20                           | 3-104-048    |
| Snap-in        | 1.5                    | Quick connect terminals 6.3 x 0.8 mm | IP20                           | 3-101-785    |
| Snap-in        | 2.0                    | Quick connect terminals 6.3 x 0.8 mm | IP20                           | 3-104-044    |

Most Popular.

Availability for all products can be searched real-time: <https://www.schurter.com/en/Stock-Check/Stock-Check-SCHURTER>

Packaging unit 50 Pcs

Mating Inlets/Plugs

Category / Description



[Plug Overview complete](#)

IEC Plug 400 VDC, Rewireable, Straight, max. Cable Diameter 9.2 mm

GP21

[Plug further types to GS21](#)