

Jul.1.2019 Copyright 2019 HIROSE ELECTRIC CO., LTD. All Rights Reserved.
 In case of consideration for using Automotive equipment / device which demand high reliability, kindly contact our sales window correspondents.

B(Figure.1 Locked State External View)

Figure.2 Applicable Contact (Commercial Item)
(Free)

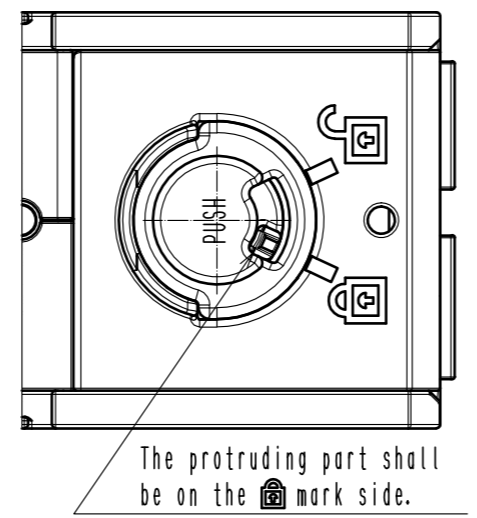
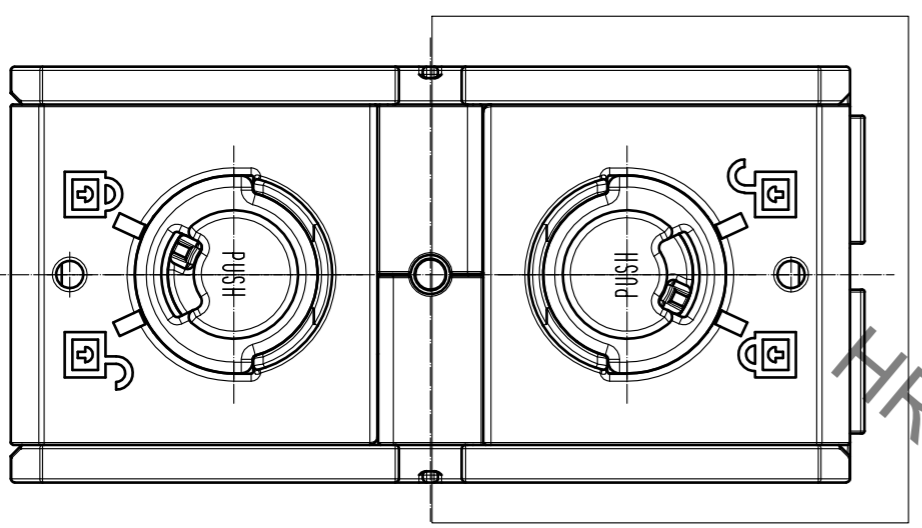

The protruding part shall be on the mark side.

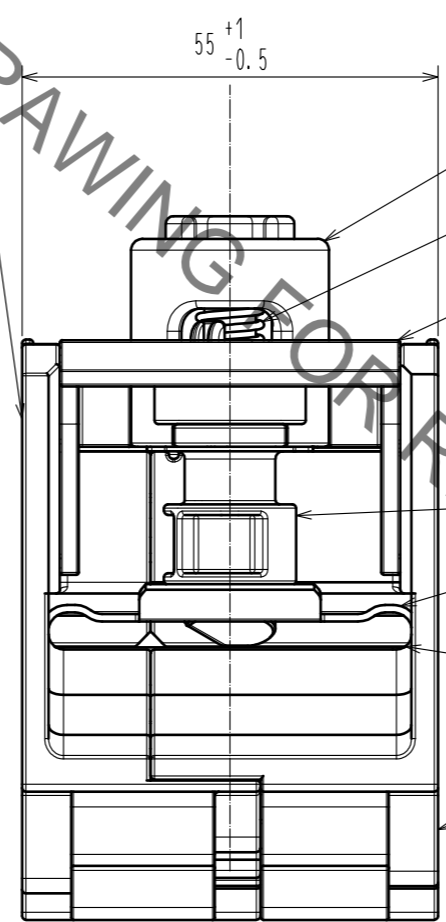
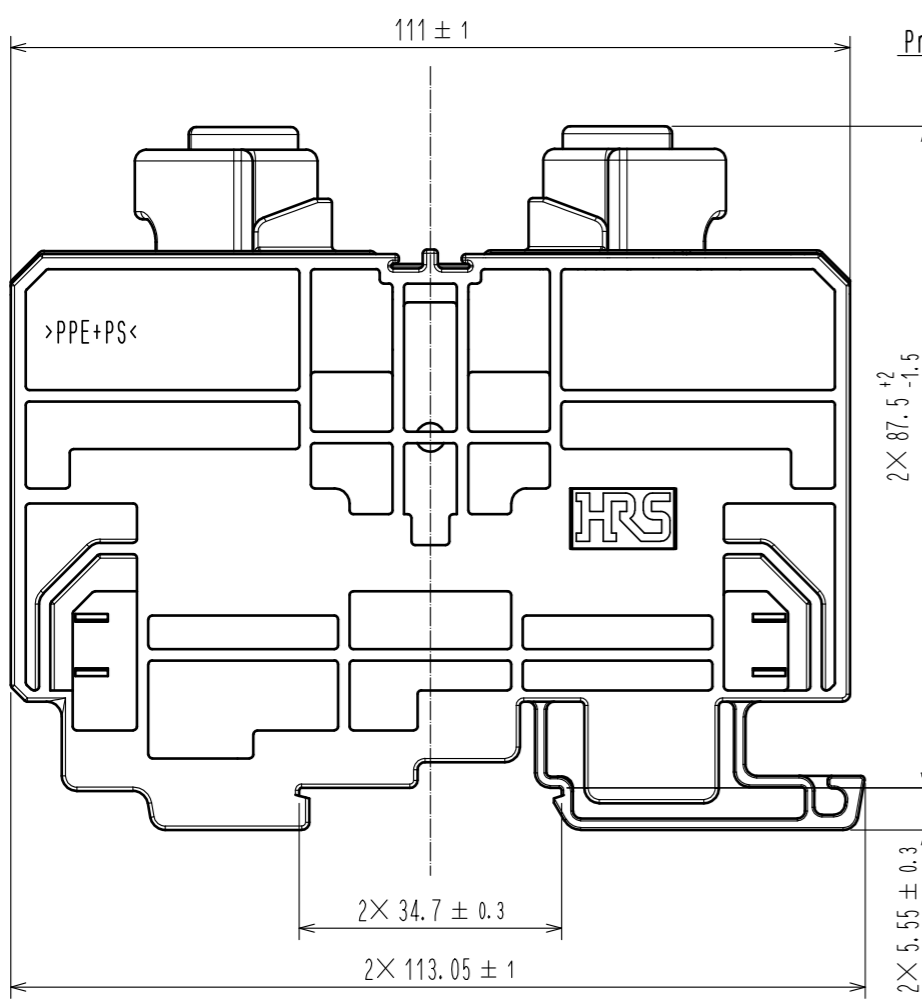
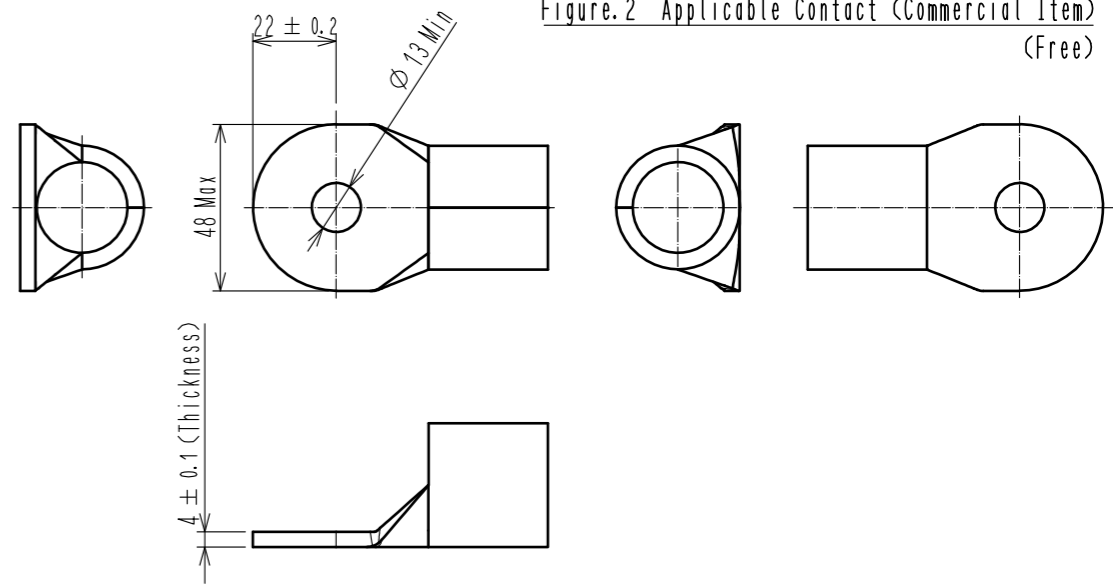

- Notes
- Applicable crimp contact: NICHIFU CO.,LTD R200-12S or J.S.T.MFG.CO.,LTD R200-12 or a similar product.
 - Applicable crimping tool: JIS-C-9711 IZUMI CO.,LTD REC-Li325.
 - Please assemble this product in coordination with the assembly manual ETAD-C0387-00.
 - When inserting the contact, please do so until Ref. No. ④ rotates back to its original position (shown in Figure.1 Locked State External View). Furthermore, lightly pull the cable to confirm that the contact is locked and mated.
 - Points to note before use:
 - Use only tin coated material.
 - Please check that dimensions satisfy those of Figure.2 and that there is no deformation, dirt etc., or abnormal contact resistance value.
 - Insertion and withdrawal forces, as well as contact resistance values could change due to the quality of the coating. Therefore, please evaluate beforehand.
- Warning 6. This product is not hot pluggable.
 Warning 7. Keep your fingers and other conductors from coming into contact with the electrically charged parts in order to avoid electrical shock or a short circuit.

4	PBT	(Red) UL94V-0	8	m-PPE	(Black) UL94V-0
3	Stainless steel		7	m-PPE	(Black) UL94V-0
2	Copper	Tin plating 1μm min	6	PBT	(Black) UL94V-0
1	m-PPE	(Black) UL94V-0	5	Stainless steel	
NO.	MATERIAL	FINISH . REMARKS	NO.	MATERIAL	FINISH . REMARKS
UNITS		SCALE	COUNT	DESCRIPTION OF REVISIONS	
mm		1 : 1	△	DESIGNED	CHECKED
HIROSE ELECTRIC CO., LTD.		APPROVED	17.08.03	DRAWING NO. EDC-119469-00-00	
		CHECKED	17.08.02	PART NO. EF2-D400-1	
		DESIGNED	17.08.02	CODE NO. CL142-0102-0-00	
		DRAWN	17.08.02	1/1	