

Art.-Number: 701132

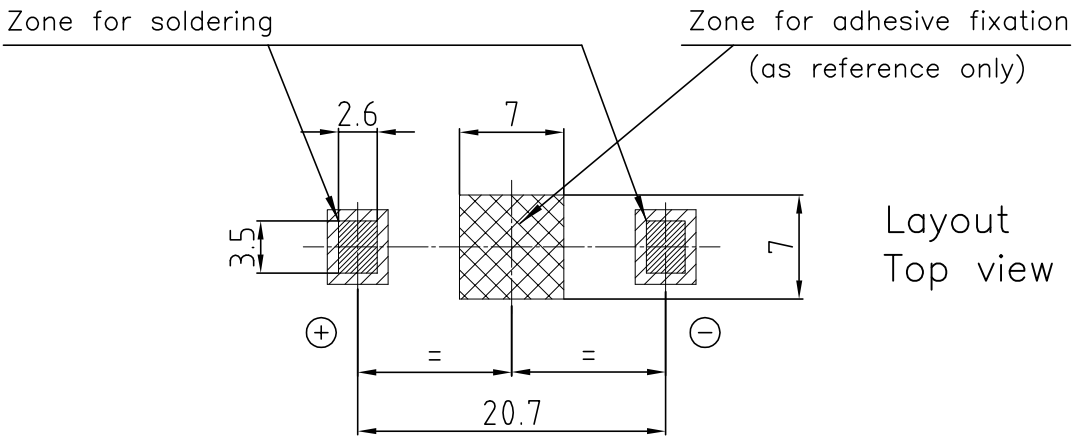
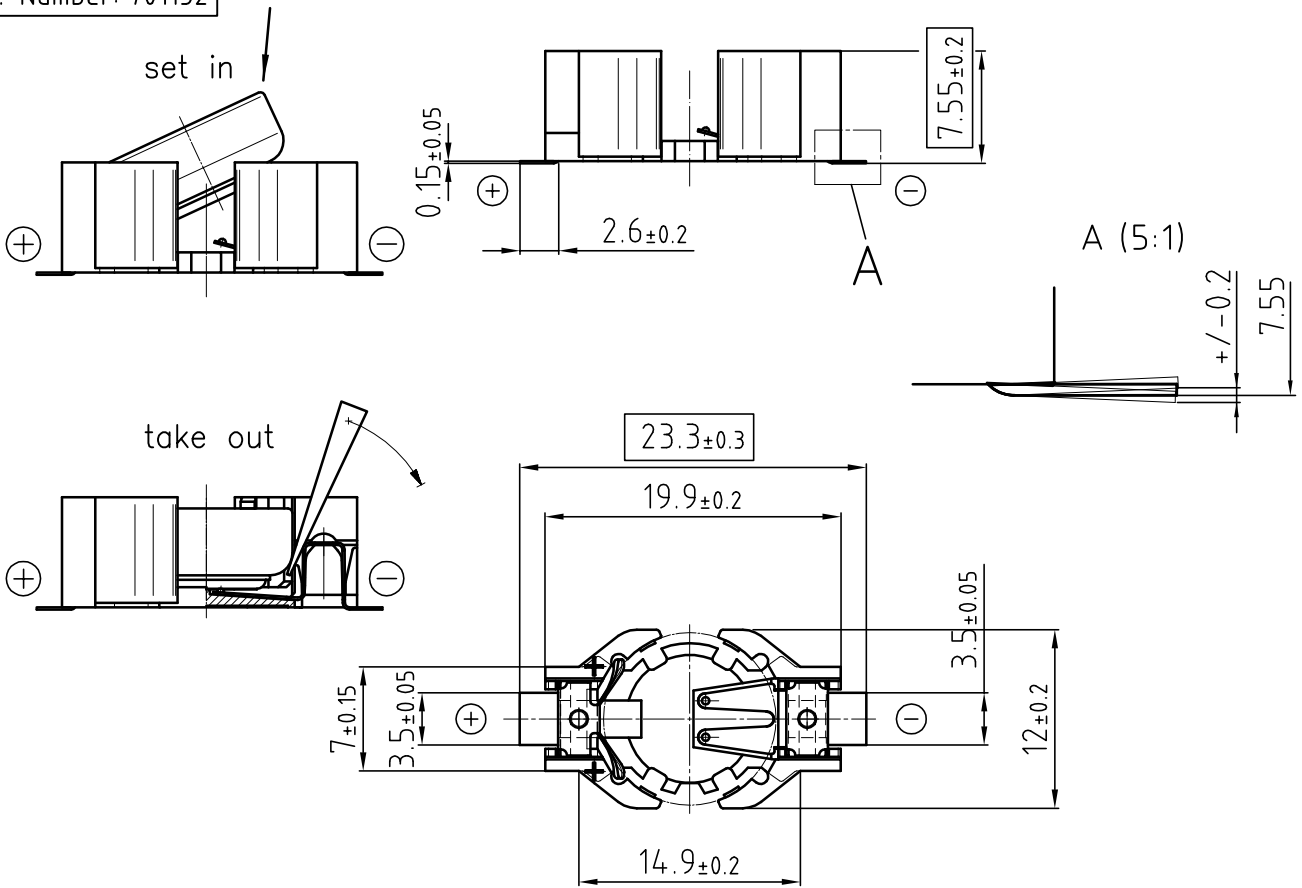

- Samples can deviate in the execution from the serie.

- Dimensions and tolerances can be specified only after the testing of the devices for the mass production definitely

- Holder material : heat resistant, glass-fiber reinforced LCP
- Battery contacts : spring stainless steel 301 nickel plated throughout
- Solder contacts : spring stainless steel 301 solder area tin-plated throughout, min. thickness 5µm

All framed values will be used for dimension checking !

Rev.	①	07.09.07	MCi	Rev.	○			Customer's Approval		
Rev.	②	25.10.07	SRI	Rev.	○			Date		
Rev.	③	15.09.10	Wu Ping	Rev.	○			Signature		
Titel:							Scale	Drawn	01.12.05	SRI
SMTU357-LF								Checked	16.09.10	SRI
								Approved		

	CH-4452 Itingen Switzerland	3.8922.4-3
--	--------------------------------	------------