

DESCRIPTION

Demonstration circuit 2290A features the **LTC[®]2387** family. With up to 15MSPS, these differential input, single channel, 18-/16-Bit, serial, high speed successive approximation register (SAR) ADCs are available in a 32-Pin QFN package. The LTC2387 family has an internal 20ppm/°C reference and a serial LVDS interface. The following text refers to the LTC2387 but applies to all members of the family, the only difference being the sample rate and the number of bits. The DC2290A demonstrates the AC performance of the LTC2387 in conjunction with the DC718 data collection

board. Differential amplifier demo boards are available separately that provide amplification of low level differential signals if required (see Table 2). Alternatively, by connecting the DC2290A into a customer application the performance of the LTC2387 can be evaluated directly in that circuit.

Design files for this circuit board are available at <http://www.linear.com/demo/DC2290A>

LT, LT, LTC, LTM, Linear Technology and the Linear logo are registered trademarks and PScope is a trademark of Linear Technology Corporation. All other trademarks are the property of their respective owners.

BOARD PHOTO

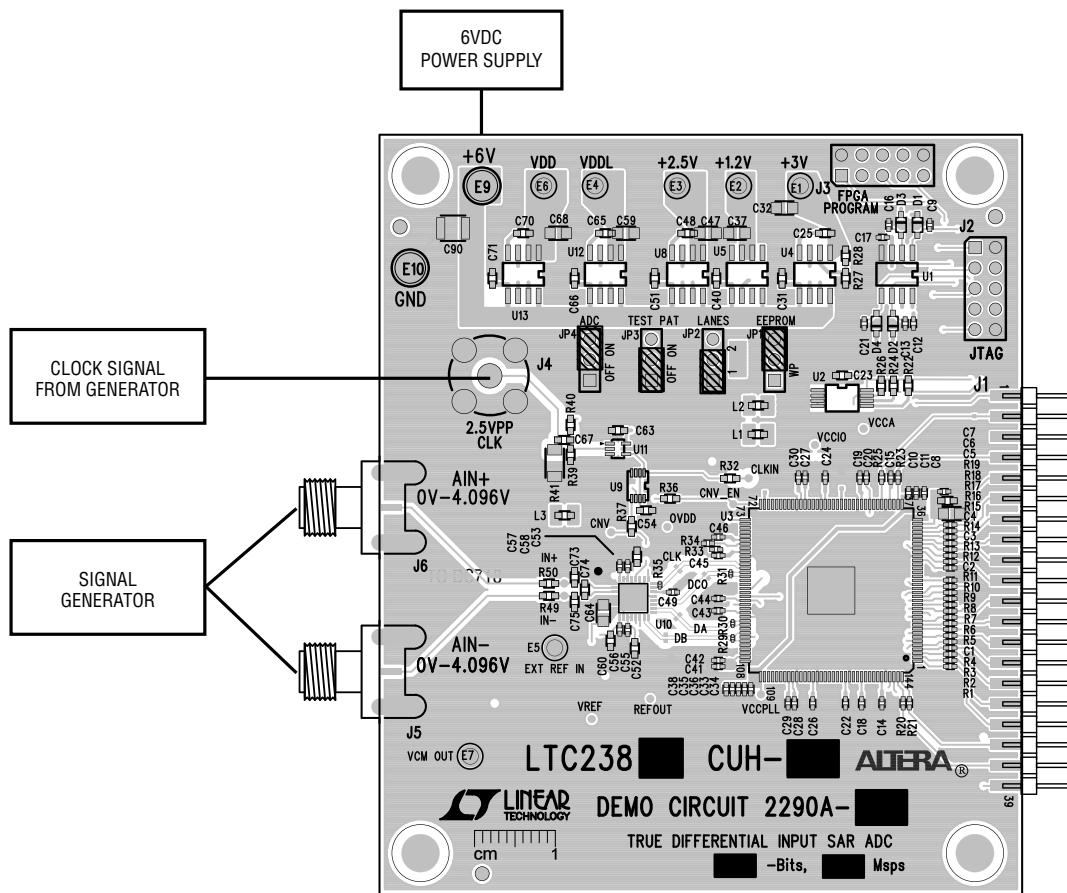

Figure 1. DC2290A Connection Diagram

DC718 QUICK START PROCEDURE

Connect the DC2290A to a DC718 USB High Speed Data Collection Board using edge connector J1. Connect the DC718 to a host PC with a standard USB A/B cable. Apply a low noise differential signal to J6 (A_{IN}^+) and J5 (A_{IN}^-). Note that the DC2290A requires a differential input signal of approximately 8.192V peak-to-peak to reach 0dBFS. If a differential signal source of this amplitude is not available use one of the recommended differential amplifier demo boards available to increase the signal level. For a clock source, apply a low jitter 10dBm sine wave or square wave to connector J4. See Table 1 for maximum clock frequen-

cies. Note that J4 has a 50 Ω termination resistor to ground. Run the PScope™ software (Pscope.exe version K73 or later) supplied with DC718 or download it from www.linear.com/software. Complete software documentation is available from the Help menu. Updates can be downloaded from the Tools menu. Check for updates periodically as new features may be added. The PScope software should recognize the DC2290A and configure itself automatically. Click the Collect button (Figure 2) to begin acquiring data. The Collect button then changes to Pause, which can be used to stop data acquisition.

Table 1. DC2290A Assembly Options

VERSION	U1 PART NUMBER	MAX CONVERSION RATE	# OF BITS	MAX CLOCK FREQUENCY
DC2290A-A	LTC2387CUH-18#PBF	15Msps	18	15MHz
DC2290A-B	LTC2387CUH-16#PBF	15Msps	16	15MHz
DC2290A-C	LTC2386CUH-18#PBF	10Msps	18	10MHz
DC2290A-D	LTC2386CUH-16#PBF	10Msps	16	10MHz
DC2290A-E	LTC2385CUH-18#PBF	5Msps	18	5MHz
DC2290A-F	LTC2385CUH-16#PBF	5Msps	16	5MHz

HARDWARE SETUP

SIGNAL CONNECTIONS

J2: JTAG. Factory use only.

J3: FPGA Program. Factory use only.

J4: CLK IN. This input has a 50 Ω termination resistor, and is intended to be driven by a low jitter, 10dBm sine or square wave. To achieve full AC performance of this part, the clock jitter should be kept under 2ps_{RMS}. This input is capacitively coupled so that the input clock can be either 0V to 3.3V or $\pm 1.65V$. This eliminates the need for level shifting. To run at the maximum conversion rate, apply the frequency specified in Table 1.

J5: A_{IN}^- Input. This is the negative signal input.

J6: A_{IN}^+ Input. This is the positive signal input.

JUMPERS

JP1: EEPROM. Factory use only.

JP2: Lanes. Use this jumper to select either single lane or two lane data output mode from the LTC2387. The default setting is 1. The 1 setting clocks out all data on pin DA of the LTC2387. The 2 setting clocks out data alternately on pins DA and DB of the LTC2387.

JP3: Test Pattern. Use this jumper to deliver a fixed repeating test pattern from the LTC2387. The default setting is OFF. The output data will be -97796 if the jumper is in the ON position in 1 lane mode, and will be -52996 in 2 lane mode.

JP4: ADC ON. Use this jumper to enable or disable the ADC. The default setting is ON.

HARDWARE SETUP

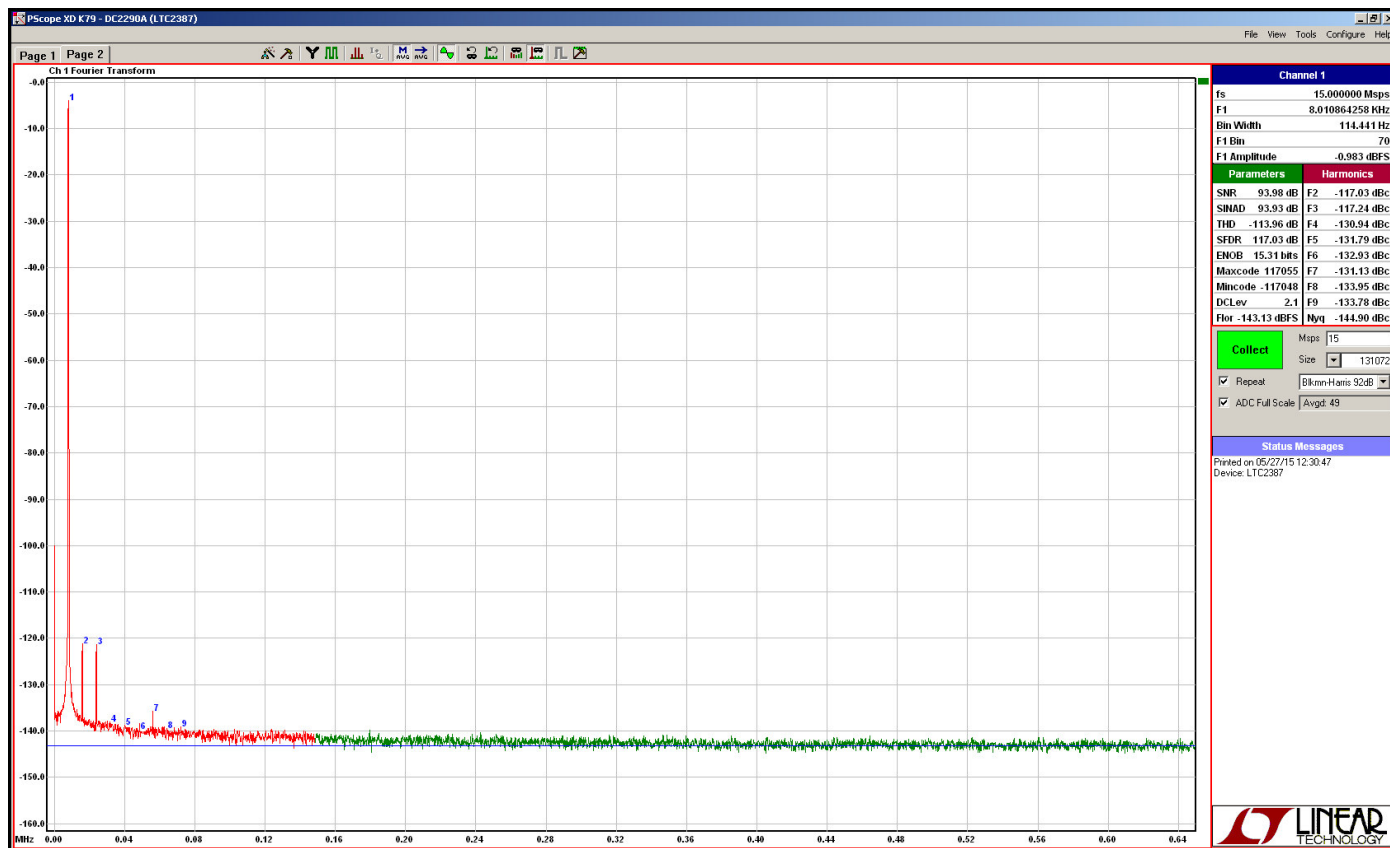

Figure 2. DC2290A PScope Screenshot

Table 2. DC2290A (LTC2387 Family) Driver Board

INPUT FREQUENCY	DRIVE BOARD	AMPLIFIER
Up to 10kHz	DC2402	LT6237
Up to 1MHz	DC2403	LT6200
> 1MHz	Contact Factory	Contact Factory

DEMO MANUAL DC2290A

PARTS LIST

ITEM	QTY	REFERENCE	PART DESCRIPTION	MANUFACTURER/PART NUMBER
DC2290A				
Required Circuit Components				
1	3	C7, C41, C42	CAP., X5R, 0.022 μ F, 25V, 10%, 0402	
2	4	C9, C13, C16, C21	CAP., NPO, 10pF, 50V, 5%, 0402	AVX, 04023A100KAT2A
3	7	C32, C37, C47, C59, C64, C68, C77	CAP., X7R, 10 μ F, 6.3V, 10%, 0805	AVX, 08056C106KAT2A
4	5	C31, C51, C66, C69, C71	CAP., X7R, 1 μ F, 10V, 10%, 0603	AVX, 0603ZC105KAT2A
5	1	C40	CAP., X5R, 3.3 μ F, 10V, 10%, 06035	C1608X5R1A335K
6	2	C5, C97	CAP., X5R, 47 μ F, 6.3V, 20%, 0805	TAIYO YUDEN, JMK212BJ476MG-T
7	1	C90	CAP., X5R, 22 μ F, 16V, 20%, 1210	AVX, 1210YD226MAT2A
8	1	C8	CAP., X5R, 0.0047 μ F, 25V, 10%, 0402	AVX, 04023D472KAT2A
9	33	C1, C2, C3, C4, C12, C14, C15, C17, C18, C19, C20, C22, C24, C26, C27, C28, C29, C30, C33, C34, C35, C36, C38, C43, C44, C45, C46, C49, C55, C56, C57, C58, C98	CAP., X5R, 0.1 μ F, 10V, 10%, 0402	AVX, 0402ZD104KAT2A
10	5	C23, C54, C63, C67, C87	CAP., X7R, 0.1 μ F, 16V, 10%, 0603	NIC, NMC0603X7R104K16TRPF
11	4	C25, C48, C65, C70	CAP., X7R, 0.01 μ F, 6.3V, 10%, 0603	MURATA, GRM188R70J103KA01D
12	2	C10, C11	CAP., X5R, 0.01 μ F, 25V, 10%, 0402	AVX, 04023D103MAT2A
13	0	C74	CAP, DNI, 0603	
14	1	C76	CAP., X7R, 2.2 μ F, 10V, 10%, 0603	AVX, 0603ZC225KAT2A
15	1	C95	CAP., X7R, 0.0022 μ F, 50V, 10%, 0402	
16	7	C6, C52, C53, C60, C80, C96, C99	CAP., X5R, 4.7 μ F, 10V, 10%, 0603	AVX 0603ZD475KAT2A
17	2	C73, C75	CAP., NPO, 82pF, 25V, 10%, 0603	AVX, 06033A820KAT2A
18	8	E1, E2, E3, E4, E5, E6, E7, E8	TEST POINT, TURRET, .064"	MILL MAX, 2308-2-00-80-00-00-07-0
19	2	E9, E10	TEST POINT, TURRET, .094"	MILL-MAX, 2501-2-00-80-00-00-07-0
20	1	J1	HEADER, 20 \times 2, 0.1IN, STRAIGHT_PINS	SAMTEC, TSW-120-07-L-D
21	2	J2, J3	HEADER, 2 \times 5, 0.100"	SAMTEC, TSW-105-07-L-D
22	2	J5, J6	CONN, SMA, 50 Ω , EDGE-LAUNCH, FEMALE	E.F. JOHNSON, 142-0701-851
23	1	J4	CONN BNC FEM JACK PC MNT STRGHT	AMPHENOL CONNEX, 112404
24	4	JP1, JP2, JP3, JP4	HEADER, 1 \times 3, 0.100"	SAMTEC, TSW-103-07-L-S
25	4	L1, L2, L3, L5	FERRITE BEAD, 33 Ω , 0603	MURATA, BLM18PG330SN1L
26	1	R44	RES., 0 Ω , 1/10W, 0603	PANASONIC, ERJ-3GEY0R00V
27	1	R71	RES., 0 Ω , 1/10W, 0402	PANASONIC, ERJ-2GEY0R00V
28	0	R38, R45, R46, R55, R57, R72	RES, DNI, 0603	
29	19	R1, R2, R3, R4, R5, R7, R8, R14, R15, R16, R17, R18, R19, R20, R21, R23, R25, R68, R69	RES., 33 Ω , 1/10W, 5%, 0402	YAGEO, RC0402JR-0733RL
30	3	R32, R36, R37	RES., 33 Ω , 1/10W, 5%, 0603	YAGEO, RC0603JR-0733RL
31	4	R29, R30, R31, R35	RES., 100 Ω , 1/10W, 1%, 0201	YAGEO, RC201FR-07101L
32	2	R49, R50	RES., 10.0 Ω , 1/10W, 1%, 0603	PANASONIC, ERJ-3EKF10R0V
33	1	R41	RES., 49.9 Ω , 1/10W, 1%, 1206	PANASONIC, ERJ-8ENF49R9V
34	7	R6, R9, R10, R12, R13, R53, R54, R70	RES., 10k, 1/10W, 5%, 0402	PANASONIC, ERJ-2GEYJ103V
35	3	R22, R24, R26	RES., 4.99k, 1/10W, 5%, 0603	PANASONIC, ERJ-3GEYJ4991V
36	3	R27, R39, R40	RES., 1.00k, 1/10W, 5%, 0603	PANASONIC, ERJ-3GEYJ102V

dc2290afb

PARTS LIST

ITEM	QTY	REFERENCE	PART DESCRIPTION	MANUFACTURER/PART NUMBER
37	1	R11	RES.,1.00k, 1/10W, 5%, 0402	PANASONIC, ERJ-2GEYJ102V
38	1	R28	RES.,1.43k, 1/10W, 1%, 0603	PANASONIC, ERJ-3EKF1431V
39	1	D1, D2, D3, D4	DIODE, SCHOTTKY 30V, 200MW, SOD323	DIODE INC., BAT54WS-7-F
40	1	U1	IC, CONFIG DEVICE 4MBIT, SO8	ALTERA, EPCS4SI8N
41	1	U2	IC, EEPROM 2KBIT 400kHz, TSSOP8	MICROCHIP, 24LC024-I/ST
42	1	U3	IC, CYCLONE III FPGA 5k, EQFP144	ALTERA, EP3C5E144C7N
43	1	U4	IC, MICROPOWER REGULATOR, SO8	LINEAR TECH., LT1763CS8#PBF
44	1	U5	IC, LINEAR REGULATOR, SO8	LINEAR TECH., LT3021ES8-1.2#PBF
45	1	U11	IC, INVERTER UHS SINGLE SC70-5	FAIRCHILD, NC7SZ04P5X
46	2	U8, U12	IC, MICROPOWER REGULATOR, SO8	LINEAR TECH., LT1763CS8-2.5#PBF
47	1	U9	IC, FLIP FLOP D-TYPE LOG, US8	ON SEMI., NL17SZ74USG
48	1	U13	IC, MICROPOWER REGULATOR, SO8	LINEAR TECH., LT1763CS8-5#PBF
49	1	U14	IC, VOLTAGE REFERENCE, MSOP8	LINEAR TECH., LTC6655BHMS8-4.096#PBF
50	1	U17	IC, OP-AMP, TSOT23-5	LINEAR TECH., LT6202CS5#PBF
51	6	SHOWN ON ASSY DWG	SHUNT, 0.100	SAMTEC, SNT-100-BK-G
52	4	MH1-MH4	STANDOFF, NYLON 0.25"	KEYSTONE, 8831 (SNAP ON)

DC2290A-A

1	0	R34	RES, DNI, 0402	
2	1	R33	RES.,1.00k, 1/10W, 5%, 0402	PANASONIC, ERJ-2GEYJ102V
3	1	U10	I.C., SAR ADC, QFN32UH-5x5	LINEAR TECH., LTC2387CUH-18#PBF

DC2290A-B

1	1	R34	RES.,1.00k, 1/10W, 5%, 0402	PANASONIC, ERJ-2GEYJ102V
2	0	R33	RES.,DNI, 0402	
3	1	U10	I.C., SAR ADC, QFN32UH-5x5	LINEAR TECH., LTC2387CUH-16#PBF

DC2290A-C

1	0	R34	RES, DNI, 0402	
2	1	R33	RES.,1.00k, 1/10W, 5%, 0402	PANASONIC, ERJ-2GEYJ102V
3	1	U10	I.C., SAR ADC, QFN32UH-5x5	LINEAR TECH., LTC2386CUH-18#PBF

DC2290A-D

1	1	R34	RES.,1.00k, 1/10W, 5%, 0402	PANASONIC, ERJ-2GEYJ102V
2	0	R33	RES.,DNI, 0402	
3	1	U10	I.C., SAR ADC, QFN32UH-5x5	LINEAR TECH., LTC2386CUH-16#PBF

DC2290A-E

1	0	R34	RES, DNI, 0402	
2	1	R33	RES.,1.00k, 1/10W, 5%, 0402	PANASONIC, ERJ-2GEYJ102V
3	1	U10	I.C., SAR ADC, QFN32UH-5x5	LINEAR TECH., LTC2385CUH-18#PBF

DC2290A-F

1	1	R34	RES.,1.00k, 1/10W, 5%, 0402	PANASONIC, ERJ-2GEYJ102V
2	0	R33	RES.,DNI, 0402	
3	1	U10	I.C., SAR ADC, QFN32UH-5x5	LINEAR TECH., LTC2385CUH-16#PBF

DEMO MANUAL DC2290A

SCHEMATIC DIAGRAM

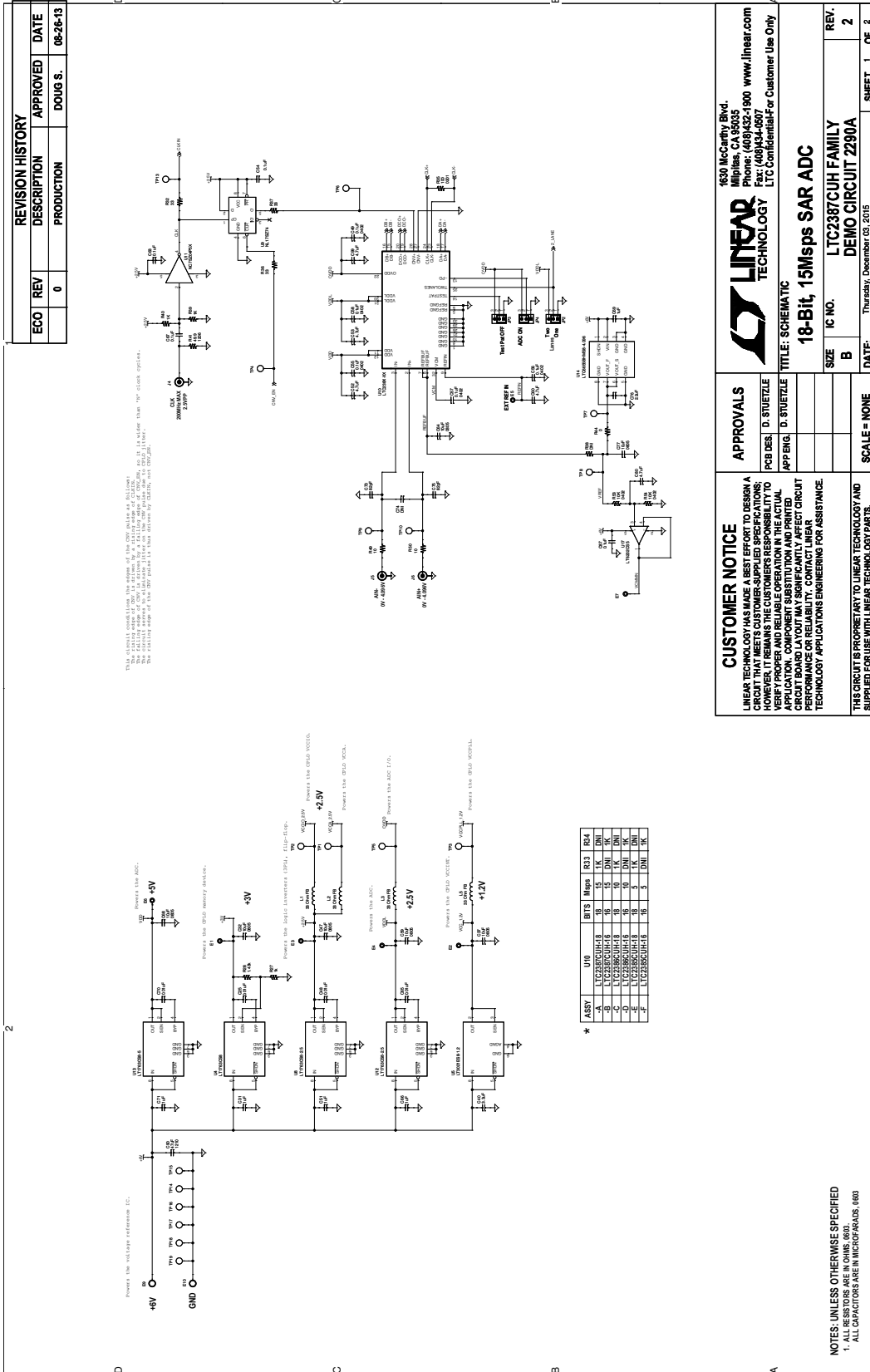

REVISION HISTORY				
ECO	REV	DESCRIPTION	APPROVED	DATE
	0	PRODUCTION	DOUG S.	08-26-13

THIS SCHEMATIC MODEL IS THE PROPERTY OF LINEAR TECHNOLOGY. IT IS PROVIDED AS A SERVICE TO OUR CUSTOMERS. IT IS NOT TO BE REPRODUCED OR TRANSMITTED IN ANY FORM OR BY ANY MEANS, ELECTRONIC OR MECHANICAL, INCLUDING PHOTOCOPYING, RECORDING, OR BY ANY INFORMATION STORAGE AND RETRIEVAL SYSTEM. THE SCHEMATIC MODEL IS PROVIDED AS IS WITHOUT WARRANTY OF ANY KIND, EXPRESS OR IMPLIED, INCLUDING BUT NOT LIMITED TO THE WARRANTIES OF MERCHANTABILITY, FITNESS FOR A PARTICULAR PURPOSE, AND NONINFRINGEMENT OF THIRD PARTY RIGHTS. ALL RIGHTS ARE RESERVED. THIS SCHEMATIC MODEL IS PROVIDED AS A SERVICE TO OUR CUSTOMERS. IT IS NOT TO BE REPRODUCED OR TRANSMITTED IN ANY FORM OR BY ANY MEANS, ELECTRONIC OR MECHANICAL, INCLUDING PHOTOCOPYING, RECORDING, OR BY ANY INFORMATION STORAGE AND RETRIEVAL SYSTEM. THE SCHEMATIC MODEL IS PROVIDED AS IS WITHOUT WARRANTY OF ANY KIND, EXPRESS OR IMPLIED, INCLUDING BUT NOT LIMITED TO THE WARRANTIES OF MERCHANTABILITY, FITNESS FOR A PARTICULAR PURPOSE, AND NONINFRINGEMENT OF THIRD PARTY RIGHTS. ALL RIGHTS ARE RESERVED.

LINEAR TECHNOLOGY

1630 McCarthy Blvd.
Milpitas, CA 95035
Phone: (408)432-1900 www.linear.com
Fax: (408)434-0077
LTC Confidential-For Customer Use Only

APPROVALS

DESIGNER: D. STUETZLE
CHECKED: D. STUETZLE
APPEN: D. STUETZLE

CUSTOMER NOTICE

LINEAR TECHNOLOGY HAS MADE A BEST EFFORT TO DESIGN A CIRCUIT THAT MEETS CUSTOMER-SUPPLIED SPECIFICATIONS AND MEETS CUSTOMER-SUPPLIED REQUIREMENTS. CUSTOMERS SHOULD VERIFY PROPER AND RELIABLE OPERATION IN THE ACTUAL APPLICATION. COMPONENT SUBSTITUTION AND PRINTED CIRCUIT BOARD LAYOUT MAY SIGNIFICANTLY AFFECT CIRCUIT PERFORMANCE OR RELIABILITY. CONTACT LINEAR TECHNOLOGY APPLICATION ENGINEERING FOR ASSISTANCE.

THIS CIRCUIT IS PROPRIETARY TO LINEAR TECHNOLOGY AND SUPPLIED FOR USE WITH LINEAR TECHNOLOGY PARTS.

18-Bit, 15MSPS SAR ADC

SIZE: B IC NO: LTC2387CUH FAMILY: DEMO CIRCUIT 2290A REV: 2

DATE: Thursday, December 03, 2015 SHEET 1 OF 2

NOTES: UNLESS OTHERWISE SPECIFIED
1. ALL CAPACITORS ARE IN MICROFARADS (µF)

SCHEMATIC DIAGRAM

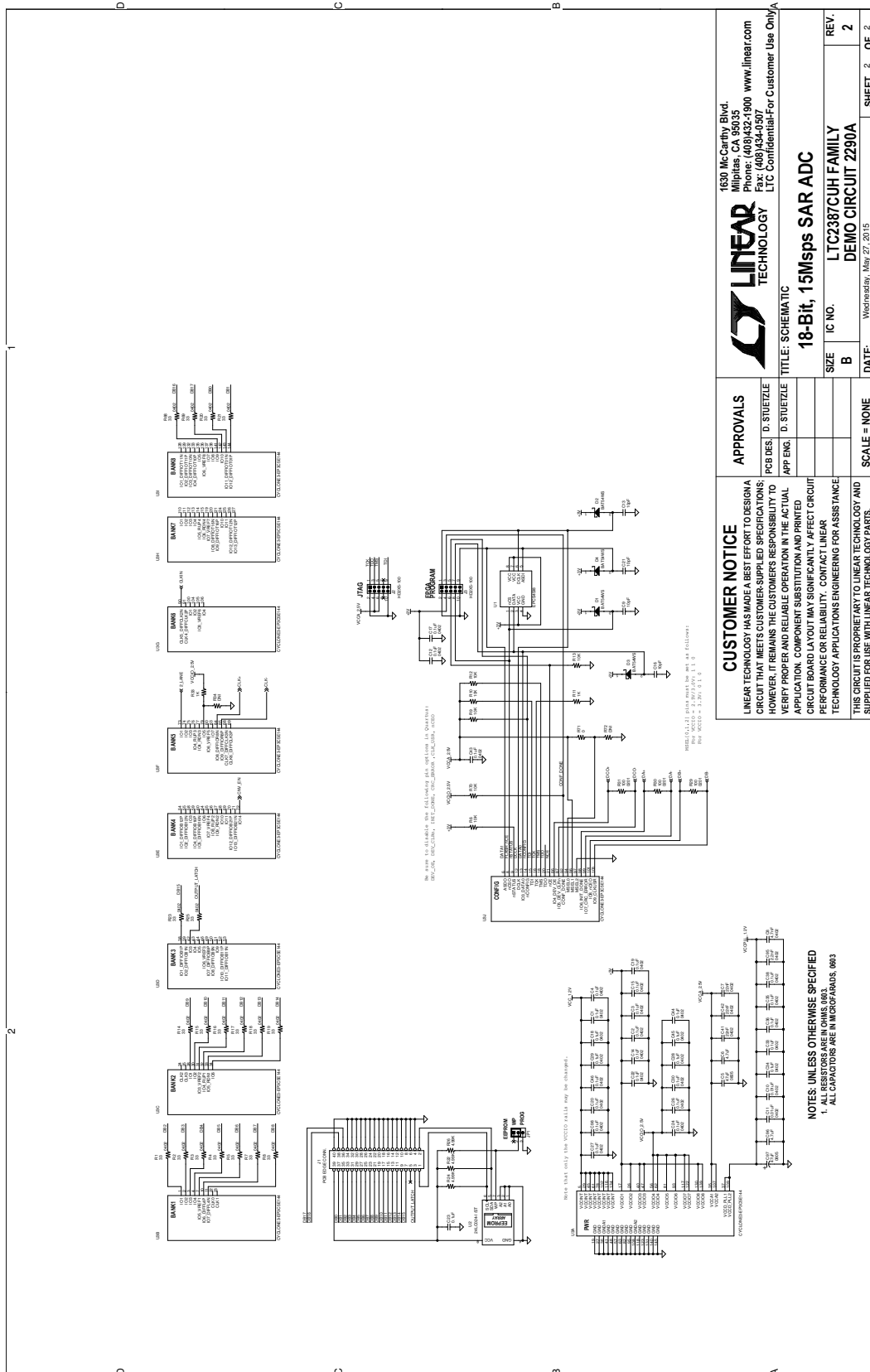

DEMO MANUAL DC2290A

DEMONSTRATION BOARD IMPORTANT NOTICE

Linear Technology Corporation (LTC) provides the enclosed product(s) under the following **AS IS** conditions:

This demonstration board (DEMO BOARD) kit being sold or provided by Linear Technology is intended for use for **ENGINEERING DEVELOPMENT OR EVALUATION PURPOSES ONLY** and is not provided by LTC for commercial use. As such, the DEMO BOARD herein may not be complete in terms of required design-, marketing-, and/or manufacturing-related protective considerations, including but not limited to product safety measures typically found in finished commercial goods. As a prototype, this product does not fall within the scope of the European Union directive on electromagnetic compatibility and therefore may or may not meet the technical requirements of the directive, or other regulations.

If this evaluation kit does not meet the specifications recited in the DEMO BOARD manual the kit may be returned within 30 days from the date of delivery for a full refund. **THE FOREGOING WARRANTY IS THE EXCLUSIVE WARRANTY MADE BY THE SELLER TO BUYER AND IS IN LIEU OF ALL OTHER WARRANTIES, EXPRESSED, IMPLIED, OR STATUTORY, INCLUDING ANY WARRANTY OF MERCHANTABILITY OR FITNESS FOR ANY PARTICULAR PURPOSE. EXCEPT TO THE EXTENT OF THIS INDEMNITY, NEITHER PARTY SHALL BE LIABLE TO THE OTHER FOR ANY INDIRECT, SPECIAL, INCIDENTAL, OR CONSEQUENTIAL DAMAGES.**

The user assumes all responsibility and liability for proper and safe handling of the goods. Further, the user releases LTC from all claims arising from the handling or use of the goods. Due to the open construction of the product, it is the user's responsibility to take any and all appropriate precautions with regard to electrostatic discharge. Also be aware that the products herein may not be regulatory compliant or agency certified (FCC, UL, CE, etc.).

No License is granted under any patent right or other intellectual property whatsoever. **LTC assumes no liability for applications assistance, customer product design, software performance, or infringement of patents or any other intellectual property rights of any kind.**

LTC currently services a variety of customers for products around the world, and therefore this transaction **is not exclusive**.

Please read the DEMO BOARD manual prior to handling the product. Persons handling this product must have electronics training and observe good laboratory practice standards. **Common sense is encouraged.**

This notice contains important safety information about temperatures and voltages. For further safety concerns, please contact a LTC application engineer.

Mailing Address:

Linear Technology
1630 McCarthy Blvd.
Milpitas, CA 95035

Copyright © 2004, Linear Technology Corporation