

MOLEX P/N	LENGTH	TOLERANCE	JACKET RATING
745461601	1M	0.05M	VW1
745461602	2M	0.05M	VW1
745461603	3M	0.05M	VW1
745461604	4M	0.10M	VW1
745461605	5M	0.10M	CL2
745461606	6M	0.13M	CL2
745461607	7M	0.13M	CL2
745461608	8M Δ	0.13M	CL2
745461609	9M Δ	0.15M	CL2
745461610	10M Δ	0.15M	CL2
745461611	0.5M	0.05M	VW1

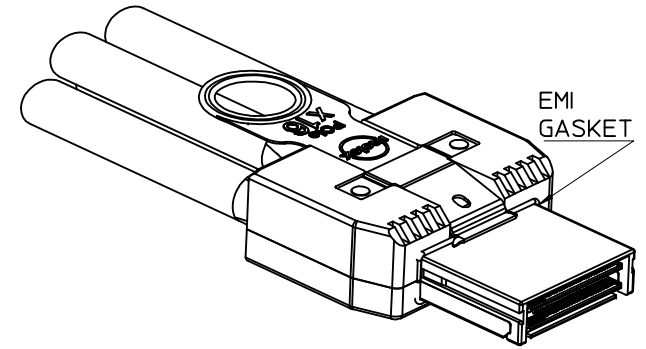

iPass™ is a trademark of Molex

- NOTES:
- MATERIAL - BACKSHELLS - ZINC DIECAST
PULL - NYLON
CABLE JACKET - SEE TABLE
 - LENGTH AND TOLERANCE - SEE TABLE
 - ELECTRICAL PERFORMANCE PER PCI EXPRESS EXTERNAL CABLING SPEC. REV 0.4
 - PLUG MATES TO RECEPTACLE - EMI GUIDE HOUSING ASSY. 75581-0001
 - NOT COMPLIANT WITH INSERTION LOSS SPEC. PER THE PCIe CABLING SPEC.
 - RoHS COMPLIANT

ADD DUST COVER EC NO: CPG2013-2029 DRWN:TPRATT 2012/12/14 CHKD:KWEBER 2012/12/14 APPR:KJANOTA 2013/01/09	QUALITY SYMBOLS	GENERAL TOLERANCES (UNLESS SPECIFIED)	DIMENSION STYLE	SCALE	DESIGN UNITS	THIRD ANGLE PROJECTION
	$\nabla=0$ $\nabla=0$	mm INCH	MM ONLY	1:1	METRIC	
		4 PLACES ± --- ± ---	DRAWN BY DATE	TITLE		
		3 PLACES ± --- ± ---	BREED 2005/01/26	I-PASS X16 CABLE ASSEMBLY GEN 1		
	2 PLACES ± 0.13 ± ---	CHECKED BY DATE	MOLEX INCORPORATED			
	1 PLACE ± 0.25 ± ---	DDOYE 2005/01/26	DOCUMENT NO. SD-74546-160			
	ANGULAR ± 1/2°	APPROVED BY DATE	SHEET NO. 1 OF 3			
		DDOYE 2005/01/26	THIS DRAWING CONTAINS INFORMATION THAT IS PROPRIETARY TO MOLEX INCORPORATED AND SHOULD NOT BE USED WITHOUT WRITTEN PERMISSION			
		MATERIAL NO.				
		SEE TABLE				
		SIZE B				

P1		P2	
GND	A1	C1	GND
PERp1	A2	C2	PETp1
PERn1	A3	C3	PETn1
GND	A4	C4	GND
PERp3	A5	C5	PETp3
PERn3	A6	C6	PETn3
GND	A7	C7	GND
PERp5	A8	C8	PETp5
PERn5	A9	C9	PETn5
GND	A10	C10	GND
PERp7	A11	C11	PETp7
PERn7	A12	C12	PETn7
GND	A13	C13	GND
NC	A14	C14	NC
NC	A15	C15	NC
NC	A16	C16	NC
SB_RTN	A17	C17	SB_RTN
GND	A18	C18	GND
CREFLCK+	A19	C19	CREFLCK+
CREFLCK-	A20	C20	CREFLCK-
GND	A21	C21	GND
PERp9	A22	C22	PETp9
PERn9	A23	C23	PETn9
GND	A24	C24	GND
PERp11	A25	C25	PETp11
PERn11	A26	C26	PETn11
GND	A27	C27	GND
PERp13	A28	C28	PETp13
PERn13	A29	C29	PETn13
GND	A30	C30	GND
PERp15	A31	C31	PETp15
PERn15	A32	C32	PETn15
GND	A33	C33	GND
NC	A34	C34	NC
GND	C1	A1	GND
PETp1	C2	A2	PERp1
PETn1	C3	A3	PERn1
GND	C4	A4	GND
PETp3	C5	A5	PERp3
PETn3	C6	A6	PERn3
GND	C7	A7	GND
PETp5	C8	A8	PERp5
PETn5	C9	A9	PERn5
GND	C10	A10	GND
PETp7	C11	A11	PERp7
PETn7	C12	A12	PERn7
GND	C13	A13	GND
NC	C14	A14	NC
NC	C15	A15	NC
NC	C16	A16	NC
SB_RTN	C17	A17	SB_RTN
GND	C18	A18	GND
CREFLCK+	C19	A19	CREFLCK+
CREFLCK-	C20	A20	CREFLCK-
GND	C21	A21	GND
PETp9	C22	A22	PERp9
PETn9	C23	A23	PERn9
GND	C24	A24	GND
PETp11	C25	A25	PERp11
PETn11	C26	A26	PERn11
GND	C27	A27	GND
PETp13	C28	A28	PERp13
PETn13	C29	A29	PERn13
GND	C30	A30	GND
PETp15	C31	A31	PERp15
PETn15	C32	A32	PERn15
GND	C33	A33	GND
NC	C34	A34	NC

P1		P2	
GND	B1	D1	GND
PERp0	B2	D2	PETp0
PERn0	B3	D3	PETn0
GND	B4	D4	GND
PERp2	B5	D5	PETp2
PERn2	B6	D6	PETn2
GND	B7	D7	GND
PERp4	B8	D8	PETp4
PERn4	B9	D9	PETn4
GND	B10	D10	GND
PERp6	B11	D11	PETp6
PERn6	B12	D12	PETn6
GND	B13	D13	GND
NC	B14	D14	NC
NC	B15	D15	NC
NC	B16	D16	NC
CPWRON	B17	D17	CPWRON
CWAKE#	B18	D18	CWAKE#
CPRSNT#	B19	D19	CPRSNT#
CPERSNT#	B20	D20	CPERSNT#
GND	B21	D21	GND
PERp8	B22	D22	PETp8
PERn8	B23	D23	PETn8
GND	B24	D24	GND
PERp10	B25	D25	PETp10
PERn10	B26	D26	PETn10
GND	B27	D27	GND
PERp12	B28	D28	PETp12
PERn12	B29	D29	PETn12
GND	B30	D30	GND
PERp14	B31	D31	PETp14
PERn14	B32	D32	PETn14
GND	B33	D33	GND
NC	B34	D34	NC
GND	D1	B1	GND
PETp0	D2	B2	PERp0
PETn0	D3	B3	PERn0
GND	D4	B4	GND
PETp2	D5	B5	PERp2
PETn2	D6	B6	PERn2
GND	D7	B7	GND
PETp4	D8	B8	PERp4
PETn4	D9	B9	PERn4
GND	D10	B10	GND
PETp6	D11	B11	PERp6
PETn6	D12	B12	PERn6
GND	D13	B13	GND
NC	D14	B14	NC
NC	D15	B15	NC
NC	D16	B16	NC
CPWRON	D17	B17	CPWRON
CWAKE#	D18	B18	CWAKE#
CPRSNT#	D19	B19	CPRSNT#
CPERSNT#	D20	B20	CPERSNT#
GND	D21	B21	GND
PETp8	D22	B22	PERp8
PETn8	D23	B23	PERn8
GND	D24	B24	GND
PETp10	D25	B25	PERp10
PETn10	D26	B26	PERn10
GND	D27	B27	GND
PETp12	D28	B28	PERp12
PETn12	D29	B29	PERn12
GND	D30	B30	GND
PETp14	D31	B31	PERp14
PETn14	D32	B32	PERn14
GND	D33	B33	GND
NC	D34	B34	NC

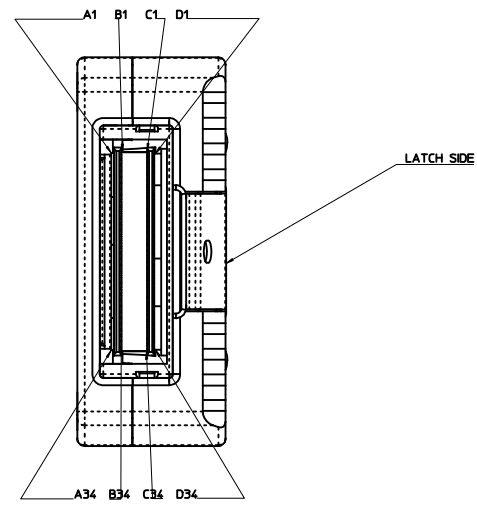

PASSTM IS A TRADEMARK OF MOLEX

ADD DUST COVER EC NO: CPG2013-2029 DRAWN: PRATT 2012/10/14 CHECKED: WEBER 2012/10/14 APPROVED: JANOTA 2013/01/09 REV: DESCRIPTION	QUALITY SYMBOLS ▽=0 ▽=0		GENERAL TOLERANCES (UNLESS SPECIFIED) <table border="1"> <thead> <tr> <th></th> <th>mm</th> <th>INCH</th> </tr> </thead> <tbody> <tr> <td>4 PLACES</td> <td>±.005</td> <td>±.0005</td> </tr> <tr> <td>3 PLACES</td> <td>±.005</td> <td>±.0005</td> </tr> <tr> <td>2 PLACES</td> <td>±.013</td> <td>±.0005</td> </tr> <tr> <td>1 PLACE</td> <td>±.025</td> <td>±.0010</td> </tr> </tbody> </table> ANGULAR ±1/2°			mm	INCH	4 PLACES	±.005	±.0005	3 PLACES	±.005	±.0005	2 PLACES	±.013	±.0005	1 PLACE	±.025	±.0010	DIMENSION STYLE MM ONLY		SCALE 1:1		DESIGN UNITS METRIC		THIRD ANGLE PROJECTION	
		mm	INCH																								
	4 PLACES	±.005	±.0005																								
	3 PLACES	±.005	±.0005																								
2 PLACES	±.013	±.0005																									
1 PLACE	±.025	±.0010																									
DRAFT WHERE APPLICABLE MUST REMAIN WITHIN DIMENSIONS			MATERIAL NO. SEE TABLE		DATE 2005/01/26		DATE 2005/01/26		TITLE I-PASS X16 CABLE ASSEMBLY GEN 1																		
			DOCUMENT NO. SD-74546-160		DATE 2005/01/26		MOLEX INCORPORATED		SHEET NO. 2 OF 3																		
THIS DRAWING CONTAINS INFORMATION THAT IS PROPRIETARY TO MOLEX INCORPORATED AND SHOULD NOT BE USED WITHOUT WRITTEN PERMISSION																											

10 9 8 7 6 5 4 3 2 1

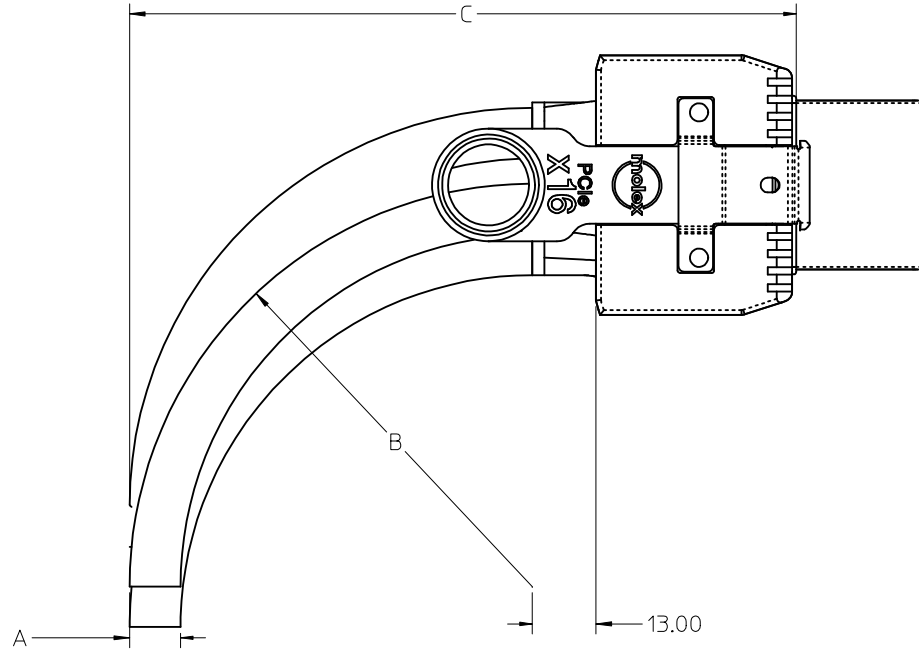

CABLE GAUGE	24	26	28
A. CABLE DIAMETER	10.4	9.3	8.4
B. MINIMUM OUTER RADIUS	46.9	41.7	37.7
C. FACEPLATE TO OUTER RADIUS	102.2	97.0	93.0

ADD DUST COVER EC NO: CPG2013-2029 DRWN:TPRATT 2012/12/14 CHKD:KWEBER 2012/12/14 APPR:KJANOTA 2013/01/09	QUALITY SYMBOLS	GENERAL TOLERANCES (UNLESS SPECIFIED)	DIMENSION STYLE MM ONLY	SCALE 1:1	DESIGN UNITS METRIC	THIRD ANGLE PROJECTION
	▽=0	4 PLACES ± --- ± ---	DRAWN BY DATE BREED 2005/01/26	TITLE I-PASS X16 CABLE ASSEMBLY GEN 1		
	▽=0	3 PLACES ± --- ± ---	CHECKED BY DATE DDOYE 2005/01/26	MATERIAL NO.		
		2 PLACES ± 0.13 ± ---	APPROVED BY DATE DDOYE 2005/01/26	DOCUMENT NO. SD-74546-160		
	1 PLACE ± 0.25 ± ---	ANGULAR ± 1/2°	SEE CHART	SHEET NO. 3 OF 3		
		DRAFT WHERE APPLICABLE MUST REMAIN WITHIN DIMENSIONS	THIS DRAWING CONTAINS INFORMATION THAT IS PROPRIETARY TO MOLEX INCORPORATED AND SHOULD NOT BE USED WITHOUT WRITTEN PERMISSION			

9 8 7 6 5 4 3 2 1