

**SJxx16xx Series**

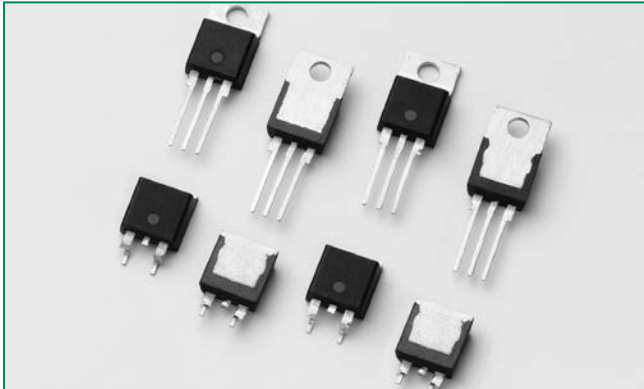

**Description**

This SJxx16xx high junction temperature SCR series is ideal for uni-directional switch applications such as phase control in heating, motor speed controls, converters/rectifiers and inrush current controllers.

These SCRs offer low gate current trigger levels of 6 mA, 10 mA, or 30 mA at approximately 1.5V.

**Features & Benefits**

- Halogen free and RoHS compliant
- Surge capability up to 225A at 60 Hz half cycle
- 150°C maximum junction temperature

**Applications**

Typical applications include AC Generator (ACG) rectifiers, battery voltage regulators, generic converters and inrush current controller in various AC and DC applications. Additional applications include controls for power tools, home/brown good and white goods appliances.

Internally constructed isolated packages are offered for ease of heat sinking with high isolation voltage.

**Agency Approvals**

AGENCY	AGENCY FILE NUMBER
	E71639*

\* - L Package Only

**Schematic Symbol**

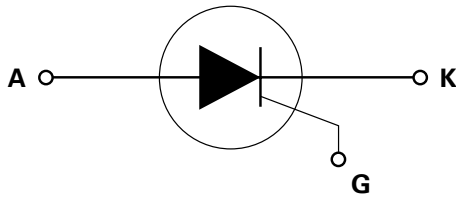

**Main Features**

Symbol	Value	Unit
$I_{T(RMS)}$	16	A
$V_{DRM}/V_{RRM}$	400 or 600	V
$I_{GT}$	6, 10 or 30	mA

**Absolute Maximum Ratings – Standard SCRs**

Symbol	Parameter	Test Conditions	Value	Unit
$V_{DRM}/V_{RSM}$	Peak non-repetitive blocking voltage	Pw=100 $\mu$ s	$V_{DRM}/V_{RRM} + 100$	V
$I_{T(RMS)}$	RMS on-state current	SJxx16Lx $T_c = 110^\circ\text{C}$	16	A
		SJxx16Rx SJxx16Nx $T_c = 135^\circ\text{C}$	16	
$I_{T(AV)}$	Average on-state current	SJxx16Lx $T_c = 110^\circ\text{C}$	10	A
		SJxx16Rx SJxx16Nx $T_c = 135^\circ\text{C}$	10	
$I_{TSM}$	Peak non-repetitive surge current	single half cycle; f = 50Hz; $T_J$ (initial) = 25°C	188	A
		single half cycle; f = 60Hz; $T_J$ (initial) = 25°C	225	
$I^2t$	$I^2t$ Value for fusing	$t_p = 8.3$ ms	210	A <sup>2</sup> s
di/dt	Critical rate of rise of on-state current	f = 60 Hz ; $T_J = 150^\circ\text{C}$	125	A/ $\mu$ s
$I_{GM}$	Peak gate current	$T_J = 150^\circ\text{C}$	3	A
$P_{G(AV)}$	Average gate power dissipation	$T_J = 150^\circ\text{C}$	0.6	W
$T_{stg}$	Storage temperature range		-40 to 150	°C
$T_J$	Operating junction temperature range		-40 to 150	°C

Note: xx=voltage/10, x=sensitivity

**Electrical Characteristics ( $T_J = 25^\circ\text{C}$ , unless otherwise specified)**

Symbol	Test Conditions		SJxx16x	SJxx16x1	SJxx16x2	Unit
$I_{GT}$	$V_D = 12\text{V}; R_L = 60\ \Omega$	MIN.	8	2	5	mA
		MAX.	30	6	10	
$V_{GT}$		MAX.	1.5	1.5	1.5	V
dv/dt	$V_D = 67\% V_{DRM};$ gate open; $T_J = 125^\circ\text{C}$	MIN.	800	70	500	V/ $\mu\text{s}$
	$V_D = 67\% V_{DRM};$ gate open; $T_J = 150^\circ\text{C}$		400	-	200	
$V_{GD}$	$V_D = V_{DRM}$ $R_L = 3.3\ \text{k}\Omega$ $T_J = 110^\circ\text{C}$	MIN.	0.2	0.2	0.2	V
$I_H$	$I_T = 200\text{mA}$ (initial)	MAX.	75	15	35	mA
$t_q$	$I_T = 2\text{A}; t_p = 50\ \mu\text{s}; dv/dt = 5\text{V}/\mu\text{s}; di/dt = 30\text{A}/\mu\text{s}$	MAX.	40	40	40	$\mu\text{s}$
$t_{gt}$	$I_G = 2 \times I_{GT}$ $PW = 15\ \mu\text{s}$ $I_T = 32\text{A}$	TYP.	2	2	2	$\mu\text{s}$

Note: xx=voltage/10, x=package

**Static Characteristics**

Symbol	Test Conditions		Value	Unit	
$V_{TM}$	Component $I_T = 32\text{A}; t_p = 380\ \mu\text{s}$	MAX.	1.6	V	
$I_{DRM} / I_{RRM}$	$V_{DRM} = V_{RRM}$	$T_J = 25^\circ\text{C}$	MAX.	10	$\mu\text{A}$
		$T_J = 125^\circ\text{C}$		1000	
		$T_J = 150^\circ\text{C}$		3000	

**Thermal Resistances**

Symbol	Parameter		Value	Unit
$R_{\theta(j-c)}$	Junction to case (AC)	SJxx16Rx SJxx16Nx	1.0	$^\circ\text{C}/\text{W}$
		SJxx16Lx	2.5	

Note: xx=voltage/10, x=sensitivity

**Figure 1: Normalized DC Gate Trigger Current vs. Junction Temperature**

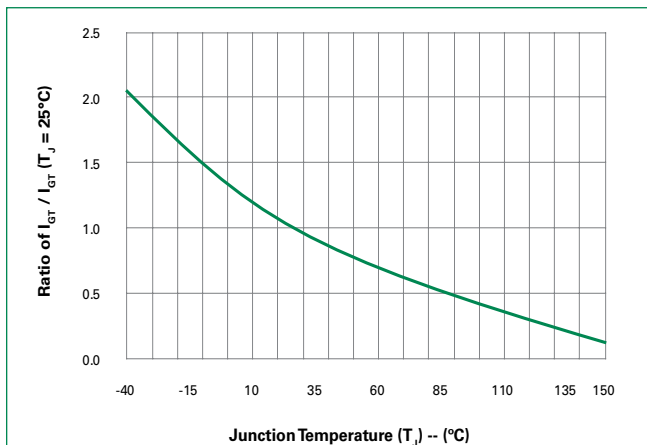

**Figure 2: Normalized DC Gate Trigger Voltage vs. Junction Temperature**

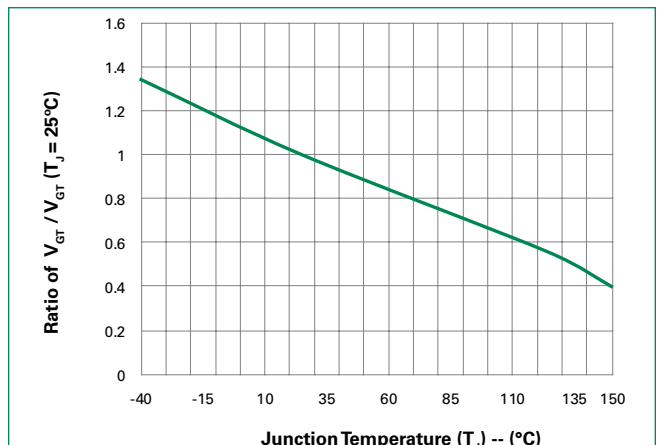

**Figure 3: Normalized DC Holding Current vs. Junction Temperature**

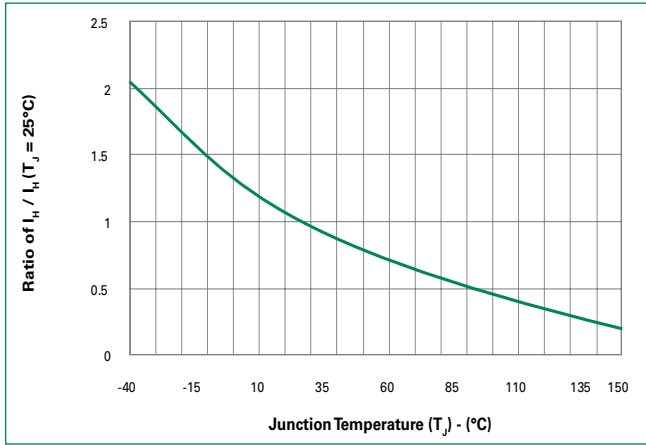

**Figure 4: On-State Current vs. On-State Voltage (Typical)**

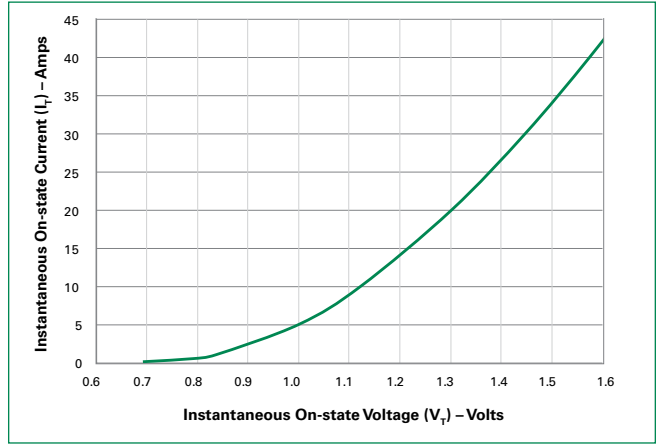

**Figure 5: Power Dissipation (Typical) vs. RMS On-State Current**

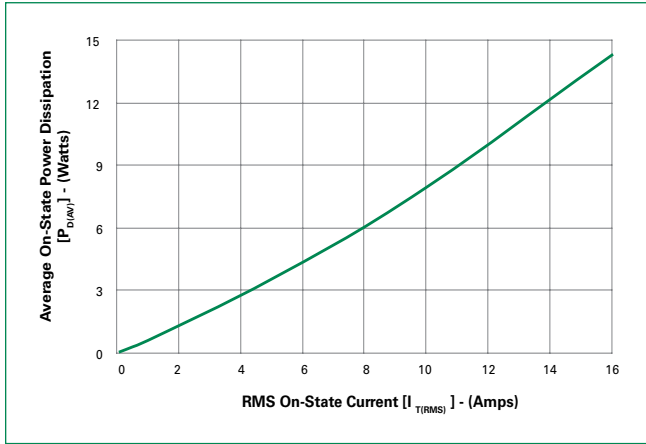

**Figure 6: Maximum Allowable Case Temperature vs. RMS On-State Current**

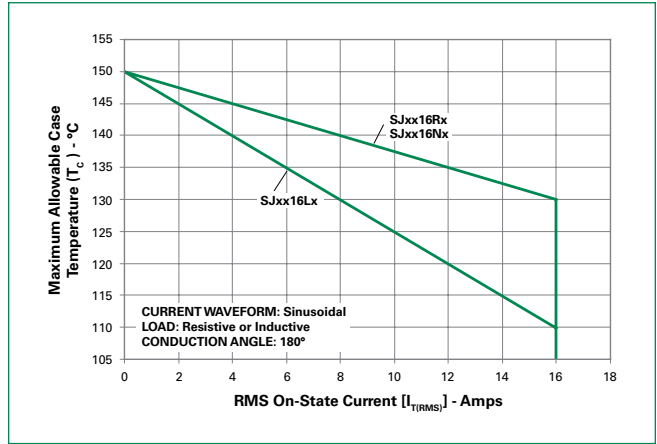

**Figure 7: Maximum Allowable Case Temperature vs. Average On-State Current**

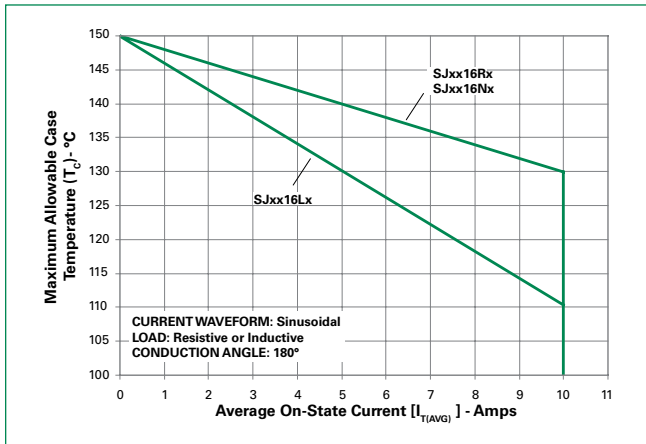

**Figure 8: Peak Capacitor Discharge Current**

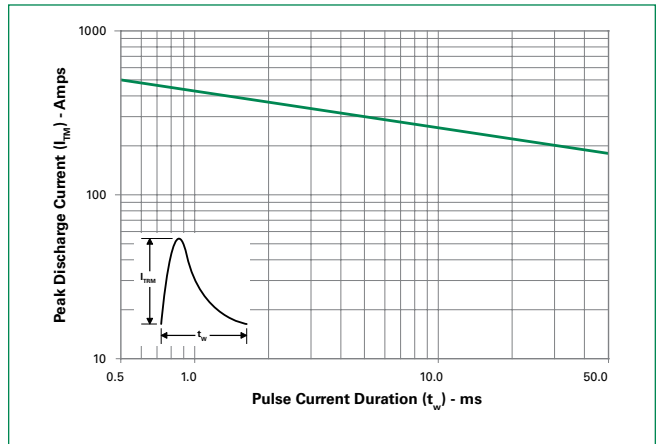

**Figure 9: Peak Capacitor Discharge Current Derating**

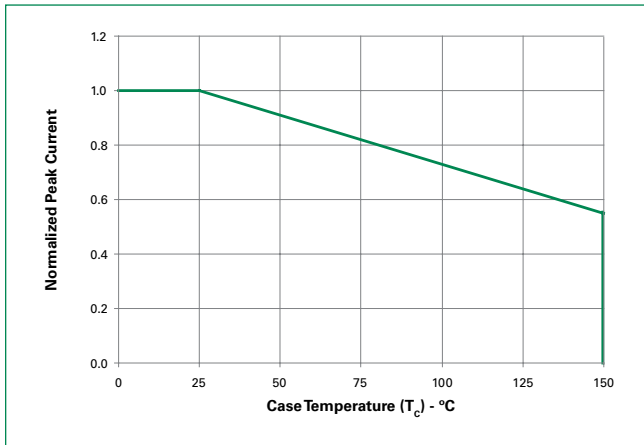

**Figure 10: Surge Peak On-State Current vs. Number of Cycles**

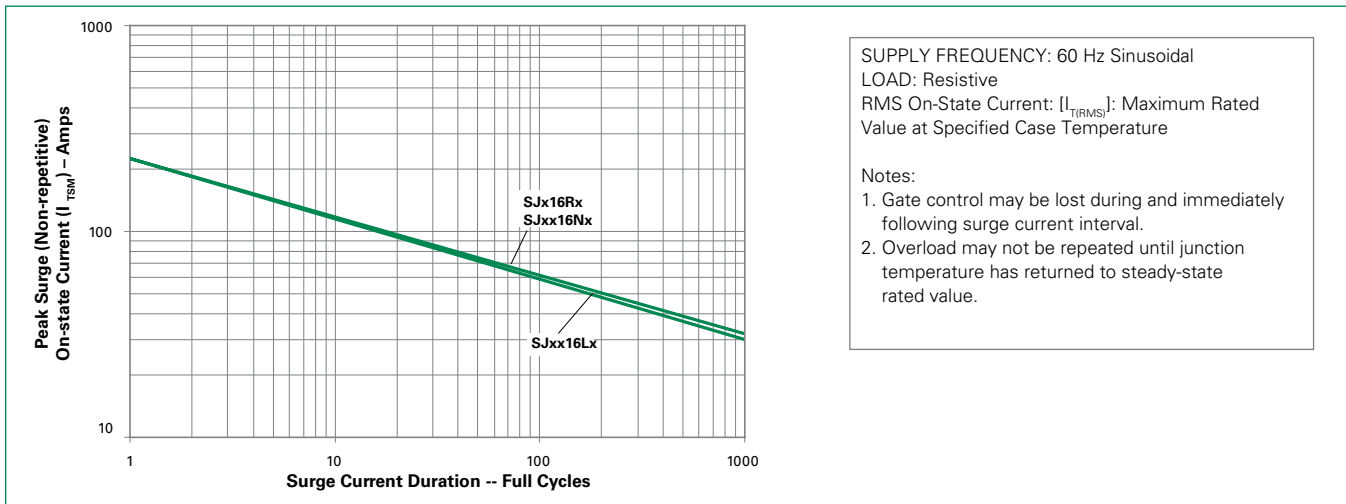

SJxx16xx Series

**Soldering Parameters**

<b>Reflow Condition</b>		Pb – Free assembly
<b>Pre Heat</b>	- Temperature Min ( $T_{s(min)}$ )	150°C
	- Temperature Max ( $T_{s(max)}$ )	200°C
	- Time (min to max) ( $t_s$ )	60 – 180 secs
<b>Average ramp up rate (Liquidus Temp) (<math>T_L</math>) to peak</b>		5°C/second max
<b><math>T_{s(max)}</math> to <math>T_L</math> - Ramp-up Rate</b>		5°C/second max
<b>Reflow</b>	- Temperature ( $T_L$ ) (Liquidus)	217°C
	- Time ( $t_L$ )	60 – 150 seconds
<b>Peak Temperature (<math>T_p</math>)</b>		260 <sup>+0/-5</sup> °C
<b>Time within 5°C of actual peak Temperature (<math>t_p</math>)</b>		20 – 40 seconds
<b>Ramp-down Rate</b>		5°C/second max
<b>Time 25°C to peak Temperature (<math>T_p</math>)</b>		8 minutes Max.
<b>Do not exceed</b>		280°C

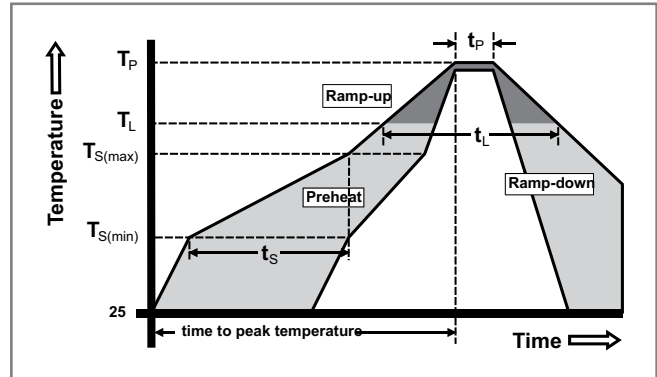

**Physical Specifications**

<b>Terminal Finish</b>	100% Matte Tin-plated
<b>Body Material</b>	UL recognized compound meeting flammability rating V-0.
<b>Lead Material</b>	Copper Alloy

**Design Considerations**

Careful selection of the correct component for the application’s operating parameters and environment will go a long way toward extending the operating life of the Thyristor. Good design practice should limit the maximum continuous current through the main terminals to 75% of the component rating. Other ways to ensure long life for a power discrete semiconductor are proper heat sinking and selection of voltage ratings for worst case conditions. Overheating, overvoltage (including dv/dt), and surge currents are the main killers of semiconductors. Correct mounting, soldering, and forming of the leads also help protect against component damage.

**Environmental Specifications**

Test	Specifications and Conditions
<b>AC Blocking</b>	MIL-STD-750, M-1040, Cond A Applied Peak AC voltage @ 150°C for 1008 hours
<b>Temperature Cycling</b>	MIL-STD-750, M-1051, 100 cycles; -55°C to +150°C; 15-min dwell-time
<b>Temperature/Humidity</b>	EIA / JEDEC, JESD22-A101 1008 hours; 160V - DC: 85°C; 85% rel humidity
<b>High Temp Storage</b>	MIL-STD-750, M-1031, 1008 hours; 150°C
<b>Low-Temp Storage</b>	1008 hours; -40°C
<b>Resistance to Solder Heat</b>	MIL-STD-750 Method 2031
<b>Solderability</b>	ANSI/J-STD-002, category 3, Test A
<b>Lead Bend</b>	MIL-STD-750, M-2036 Cond E
<b>Moisture Sensitivity Level</b>	Level 1, JEDEC-J-STD-020D

**Dimensions — TO-220AB (R-Package) — Non-Isolated Mounting Tab Common with Center Lead**

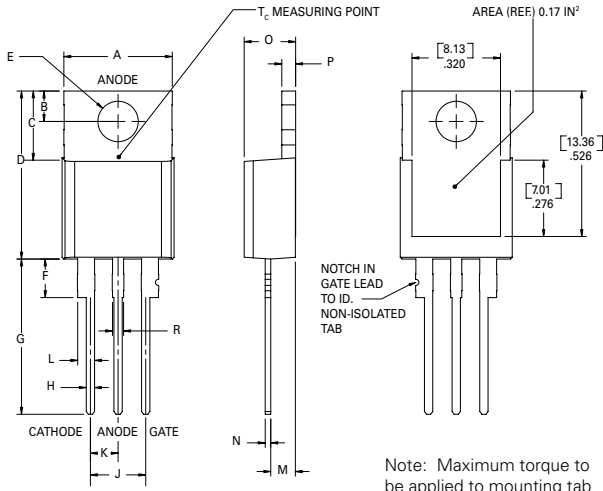

Dimension	Inches		Millimeters	
	Min	Max	Min	Max
A	0.380	0.420	9.65	10.67
B	0.105	0.115	2.67	2.92
C	0.230	0.250	5.84	6.35
D	0.590	0.620	14.99	15.75
E	0.142	0.147	3.61	3.73
F	0.110	0.130	2.79	3.30
G	0.540	0.575	13.72	14.61
H	0.025	0.035	0.64	0.89
J	0.195	0.205	4.95	5.21
K	0.095	0.105	2.41	2.67
L	0.060	0.075	1.52	1.91
M	0.085	0.095	2.16	2.41
N	0.018	0.024	0.46	0.61
O	0.178	0.188	4.52	4.78
P	0.045	0.060	1.14	1.52
R	0.038	0.048	0.97	1.22

**Dimensions — TO-220AB (L-Package) — Isolated Mounting Tab**

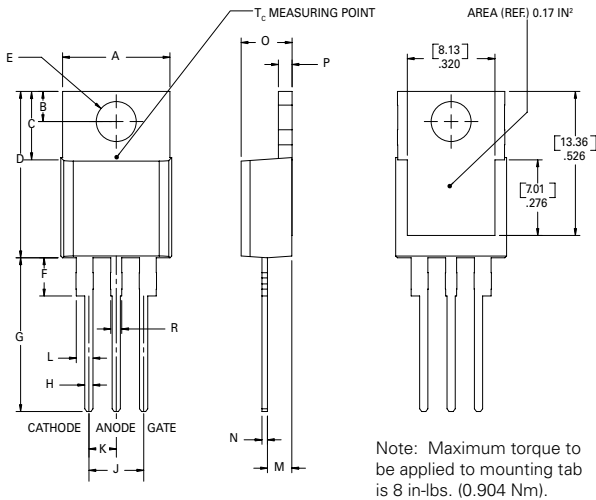

Dimension	Inches		Millimeters	
	Min	Max	Min	Max
A	0.380	0.420	9.65	10.67
B	0.105	0.115	2.67	2.92
C	0.230	0.250	5.84	6.35
D	0.590	0.620	14.99	15.75
E	0.142	0.147	3.61	3.73
F	0.110	0.130	2.79	3.30
G	0.540	0.575	13.72	14.61
H	0.025	0.035	0.64	0.89
J	0.195	0.205	4.95	5.21
K	0.095	0.105	2.41	2.67
L	0.060	0.075	1.52	1.91
M	0.085	0.095	2.16	2.41
N	0.018	0.024	0.46	0.61
O	0.178	0.188	4.52	4.78
P	0.045	0.060	1.14	1.52
R	0.038	0.048	0.97	1.22

**Dimensions – TO-263AB (N-package) – D<sup>2</sup>-Pak Surface Mount**

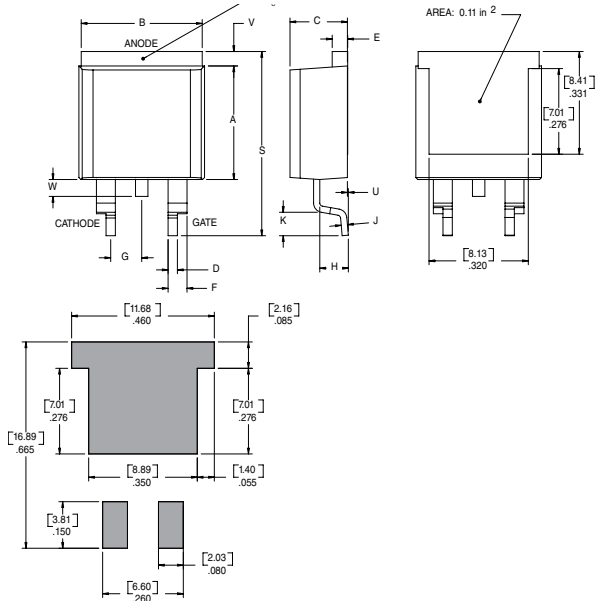

Dimension	Inches		Millimeters	
	Min	Max	Min	Max
A	0.360	0.370	9.14	9.40
B	0.380	0.420	9.65	10.67
C	0.178	0.188	4.52	4.78
D	0.025	0.035	0.64	0.89
E	0.045	0.060	1.14	1.52
F	0.060	0.075	1.52	1.91
G	0.095	0.105	2.41	2.67
H	0.092	0.102	2.34	2.59
J	0.018	0.024	0.46	0.61
K	0.090	0.110	2.29	2.79
S	0.590	0.625	14.99	15.88
V	0.035	0.045	0.89	1.14
U	0.002	0.010	0.05	0.25
W	0.040	0.070	1.02	1.78

**Product Selector**

Part Number	Voltage		Gate Sensitivity	Type	Package
	400V	600V			
SJxx16L	X	X	30mA	Standard SCR	TO-220L
SJxx16R	X	X	30mA	Standard SCR	TO-220R
SJxx16N	X	X	30mA	Standard SCR	TO-263
SJxx16L1	X	X	6mA	Standard SCR	TO-220L
SJxx16R1	X	X	6mA	Standard SCR	TO-220R
SJxx16N1	X	X	6mA	Standard SCR	TO-263
SJxx16L2	X	X	10mA	Standard SCR	TO-220L
SJxx16R2	X	X	10mA	Standard SCR	TO-220R
SJxx16N2	X	X	10mA	Standard SCR	TO-263

Note: xx = Voltage/10

**Packing Options**

Part Number	Marking	Weight	Packing Mode	Base Quantity
SJxx16LxTP	SJxx16Lx	2.2g	Tube	500 (50 per tube)
SJxx16RxTP	SJxx16Rx	2.2g	Tube	500 (50 per tube)
SJxx16NxTP	SJxx16Nx	1.6g	Tube	500 (50 per tube)
SJxx16NxRP	SJxx16Nx	1.6g	Embossed Carrier	500

Note: xx=voltage/10, x=sensitivity

### TO-263 Embossed Carrier Reel Pack (RP) Specifications

Meets all EIA-481-2 Standards

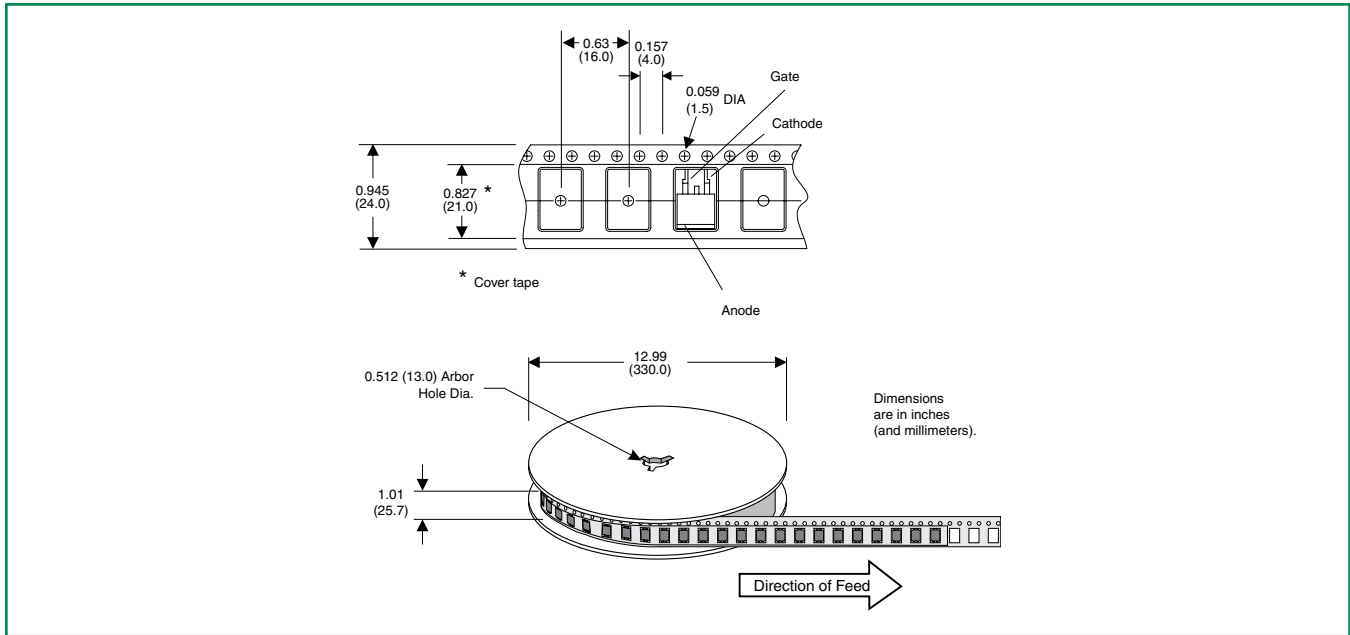

### Part Numbering System

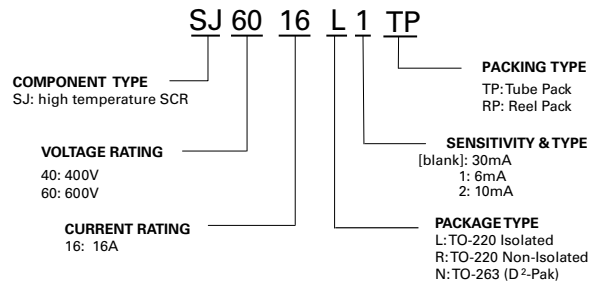

### Part Marking System

TO-220 AB - (L and R Package)  
TO-263 AB - (N Package)

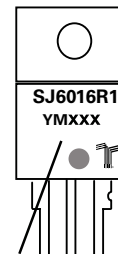

Date Code Marking  
Y: Year Code  
M: Month Code  
XXX: Lot Trace Code

**Disclaimer Notice** - Information furnished is believed to be accurate and reliable. However, users should independently evaluate the suitability of and test each product selected for their own applications. Littelfuse products are not designed for, and may not be used in, all applications. Read complete Disclaimer Notice at <http://www.littelfuse.com/disclaimer-electronics>.

©2018 Littelfuse, Inc.

Specifications are subject to change without notice.

Revision: 12/11/18