

# MS-Series

## CIRCUIT BREAKER

Designed and tested to operate flawlessly in the harshest of environments, the MS-Series sealed toggle circuit breaker is ideally suited for COTS (commercial off the shelf) military applications. Our space saving envelope meets IP68 requirements and features a durable metal and sealed mounting bushing with MIL-PRF-39019F ingress protection when mounted in a panel.

This class-leading, affordable circuit breaker was designed in accordance with the requirements of MIL-PRF-55629 and MIL STD 202, making it the best choice for those applications where shock, vibration, moisture resistance, salt spray and thermal shock are of the utmost consideration. The MS-Series' compact size and reliability make it ideal for crucial communication equipment and other mission critical components.

1-3 poles; 0.02-30 amps; 65VDC, 240VAC, 120/240VAC; UL, cUL recognized & TUV pending.

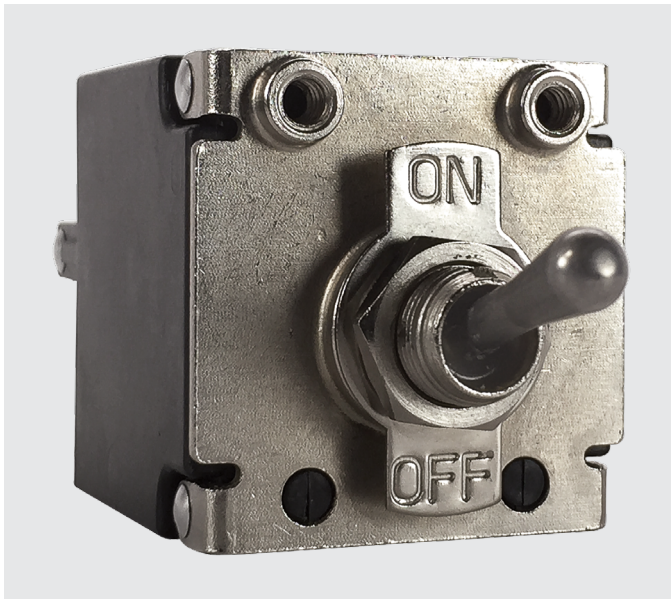

### Resources:

[Download 3D CAD Files](#)



[Watch Product Video](#)



### Product Highlights:

- ♦ Sealed Toggle Actuator
- ♦ MIL-PRF-39019F Ingress Protection
- ♦ MIL-PRF-55629 and MIL STD 202 Compliant
- ♦ Compact Design

### Typical Applications:

- ♦ COTS Military
  - Communication Equipment
- ♦ Off Highway Equipment
  - Construction, Mining & Agriculture
- ♦ Generators & Power Supplies
- ♦ Harsh Environment Applications



**Carling Technologies™**

Innovative Designs. Powerful Solutions.

**Carling Technologies, Inc.**  
60 Johnson Avenue, Plainville, CT 06062  
Email: [sales@carlingtech.com](mailto:sales@carlingtech.com)  
Application Support: [team2@carlingtech.com](mailto:team2@carlingtech.com)  
Phone: 860.793.9281 Fax: 860.793.9231

[www.carlingtech.com](http://www.carlingtech.com)

# MS-Series

## DESIGN FEATURES

### SEALS

IP68 Designed and tested to comply with MIL-PRF-39019F Ingress Protection

### COMPACT SIZE

Max performance in compact size: 0.20-30 Amps; 65 VDC, 240 VAC 120/240 VAC

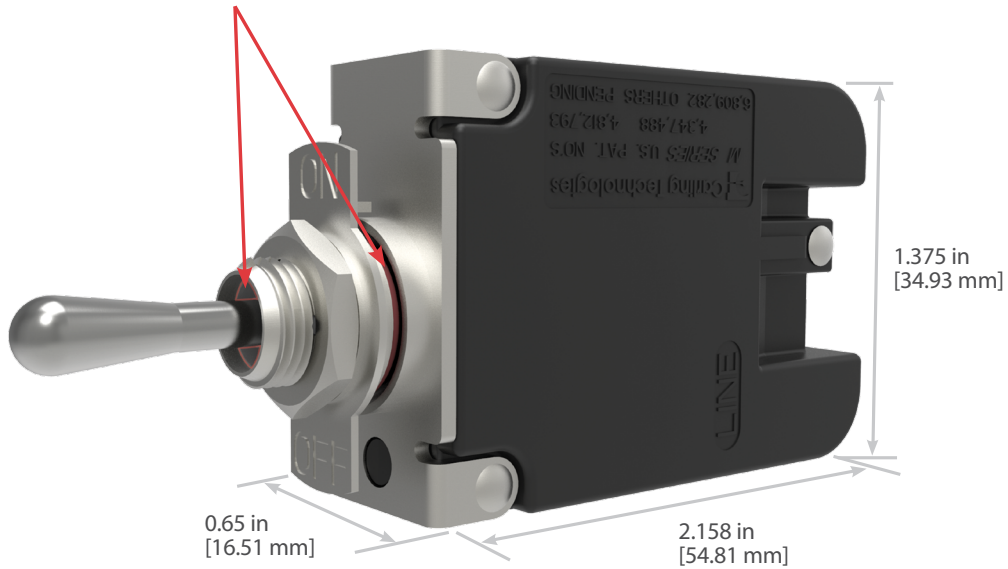

### TERMINAL BARRIERS

Meet UL 1077 Spacing Requirements

### OPTIONAL AUXILIARY SWITCH

Provides Breaker Status Indication

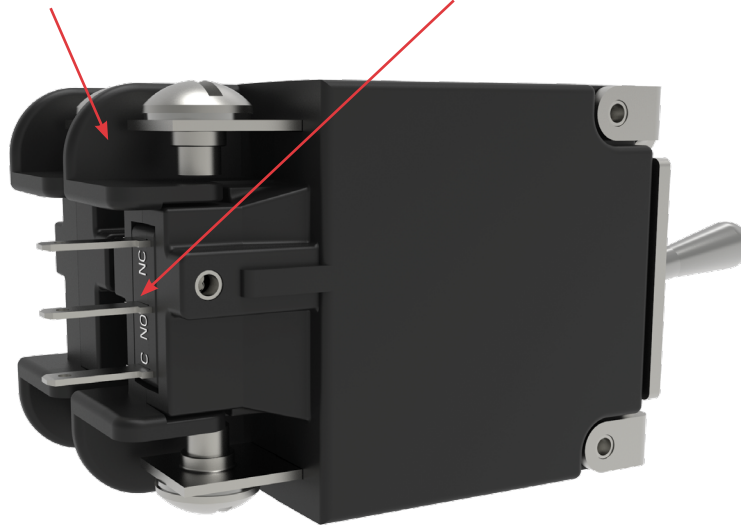

## Electrical Tables

**Table A:** Lists UL & cUL Configuration & Performance Capabilities

MS-SERIES TABLE A: COMPONENT SUPPLEMENTARY PROTECTORS							
Circuit Configuration	Voltage			Current Rating		Short Circuit Capacity (Amps) <sup>1</sup>	
	Max Rating	Frequency	Phase	General Purpose Amps	Poles Breaking	UL / cUL	
						U1	U3
Series	65	DC	---	0.02 - 30	1	3000	300
	240	50 / 60	1	0.02 - 30	1, 2	2000	300
	120 / 240	50 / 60	1	0.02 - 30	2 or 3	2000	300

**Notes:**

1 Short Circuit Current Rating (SC) Codes — The short-circuit current rating, followed by a letter and number designating the test conditions and any calibration following the short-circuit test as defined below:

U - Indicates that the short circuit test was performed without a series fuse

1 - Indicates that a re-calibration was not performed as part of the short circuit testing

3 - Indicates that the protector has proven to be suitable for further use after the short circuit test

Re-calibration, dielectric strength and voltage withstand tests were performed after the short circuit testing

### Electrical

Current Ratings	.02 - 30 Amps
Voltage Rating	65VDC, 240VAC, 120/240VAC
Short Circuit Rating	See Table A
Auxiliary Switch Rating	5A @ 125VAC, 3A @ 32VDC, .1A @ 125VAC, 32VDC
Dielectric Strength	UL,CSA 1500V, 50/60 Hz for one minute between all electrically isolated terminals.
Insulation Resistance	Minimum of 100 Megohms @ 500VDC
Time Delay	See delay curve
Impedance	

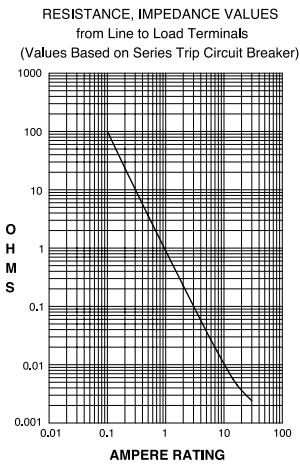

CURRENT (AMPS)	TOLERANCE (%)
0.20 - 30.0	25%

### Physical

Number of Poles	1-3 poles
Weight	Approximately 1.8 oz (50 G) per pole
Dimensions	See form & fit drawing

### Agency Certifications

UL Standard 1077



CUL Standard C22.2

### Mechanical

Current Ratings	10,000 On-Off operations @ 6 per minute with rated current and voltage.
Trip Free	Trips on short circuit and overload, even when the actuator is forcibly held in the "On" position.
Trip Indication	The operating handle moves positively to the "Off" position when a short circuit or overload causes the circuit breaker to trip.

### Environmental

Designed in accordance with requirements of specification MIL PRF-55629 & MIL-STD-202G as follows:

Shock	Withstands 100G's, 6ms, saw tooth while carrying rated current per Method 213, Condition I. Instantaneous curves tested at 80% of rated current.
Vibration	Withstands 0.060" excursion from 10-55 Hz, and 10G's 55-500 Hz, at rated current per Method 204C, Test Condition A. Instantaneous curves tested at 80% of rated current.
Salt Spray	Method 101, Condition A (90-95% RH @ 5% NaCl Solution, 96 hrs)
Moisture Resistance	Method 106G
Thermal Shock	Method 107D, Condition A (Five cycles @ -55°C to +25°C to +85°C to +25°C)
Operating Temperature	-40°C to +85°C
Ingress Protection Level	MIL-PRF-55629C when mounted in panel.
Other	Materials used in this product are non-nutrient to fungus growth.

\*Manufacturer reserves the right to change product specification without prior notice.



**Form & Fit**

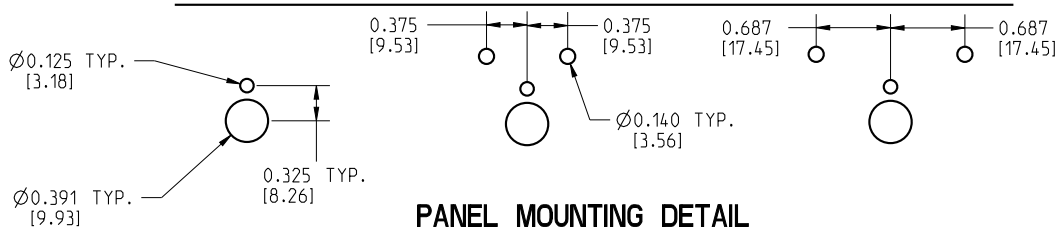
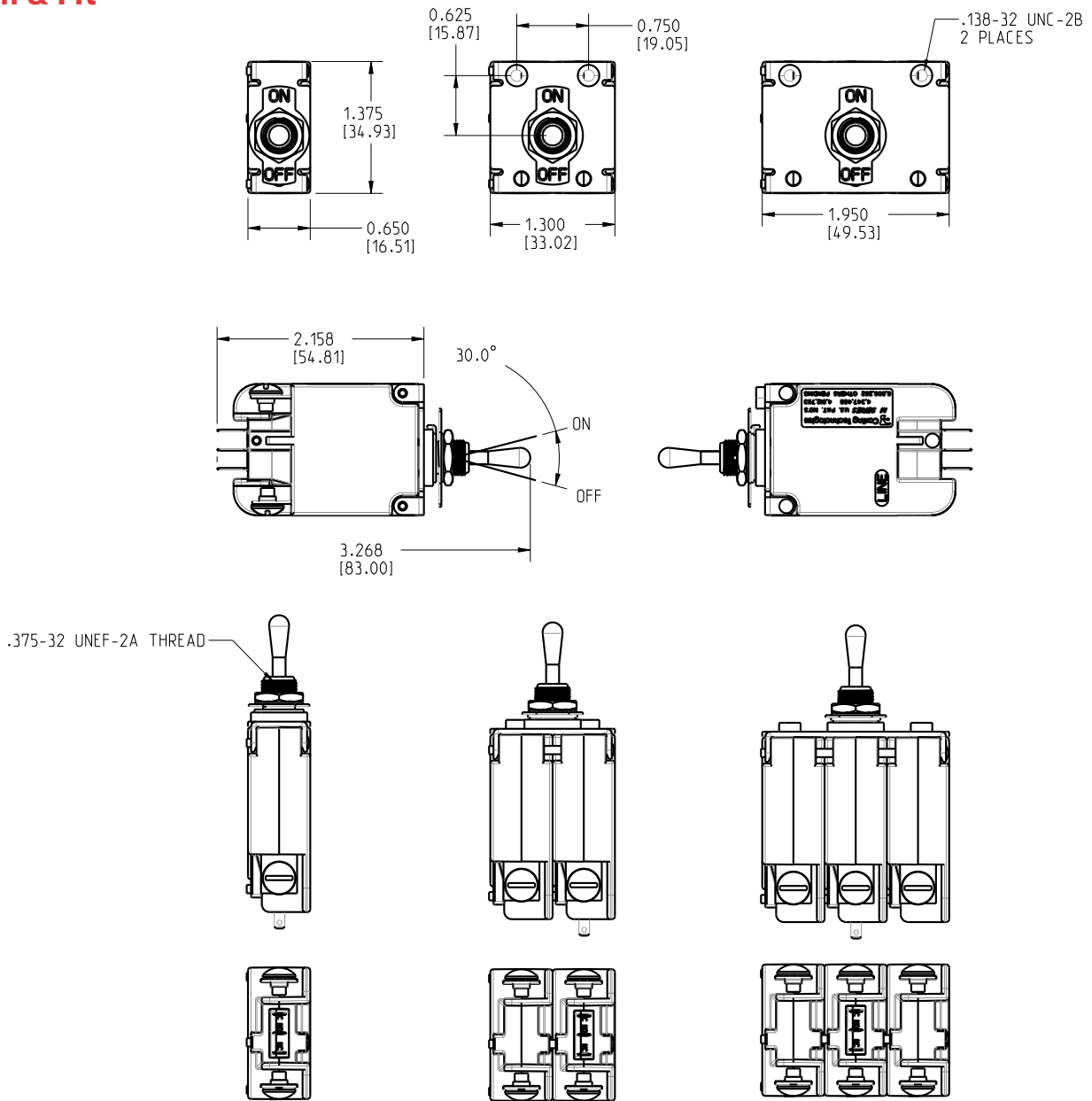

**PANEL MOUNTING DETAIL**  
**PANEL THICKNESS 0.125" TO 0.156"**

- Notes:  
 1 All dimensions are in inches [millimeters].  
 2 Tolerance ±.020 [.51] unless otherwise specified.

## Delay Curve

Dual Rated AC/DC

### Instantaneous

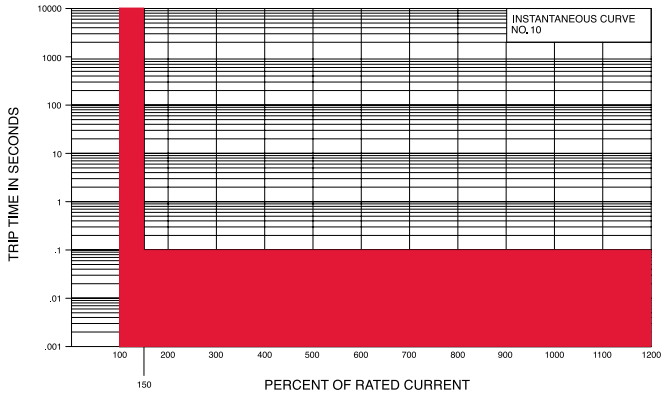

### Short

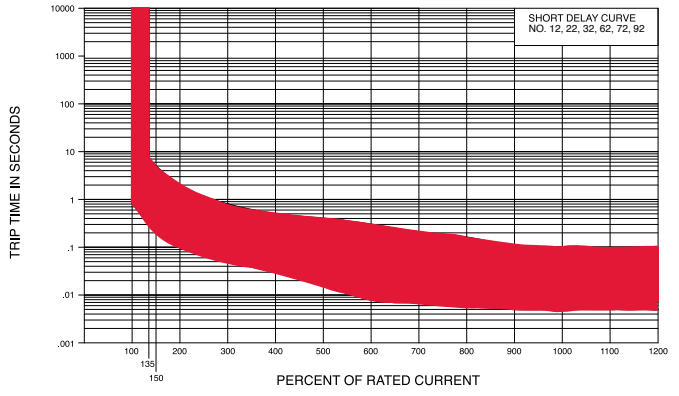

### Medium

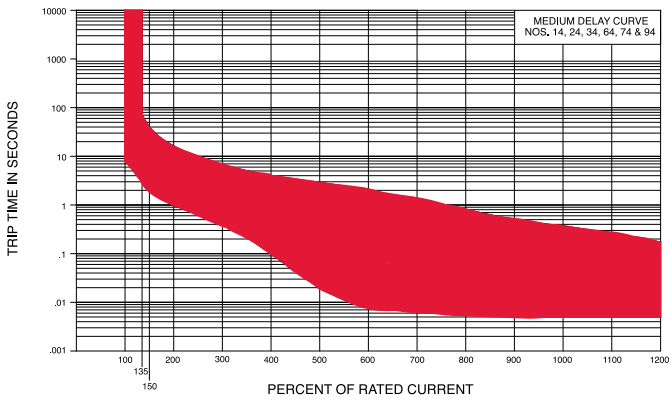

## Authorized Sales Representatives

Click on the group name on the map below to find your local representative or visit [www.carlingtech.com/findarep](http://www.carlingtech.com/findarep).

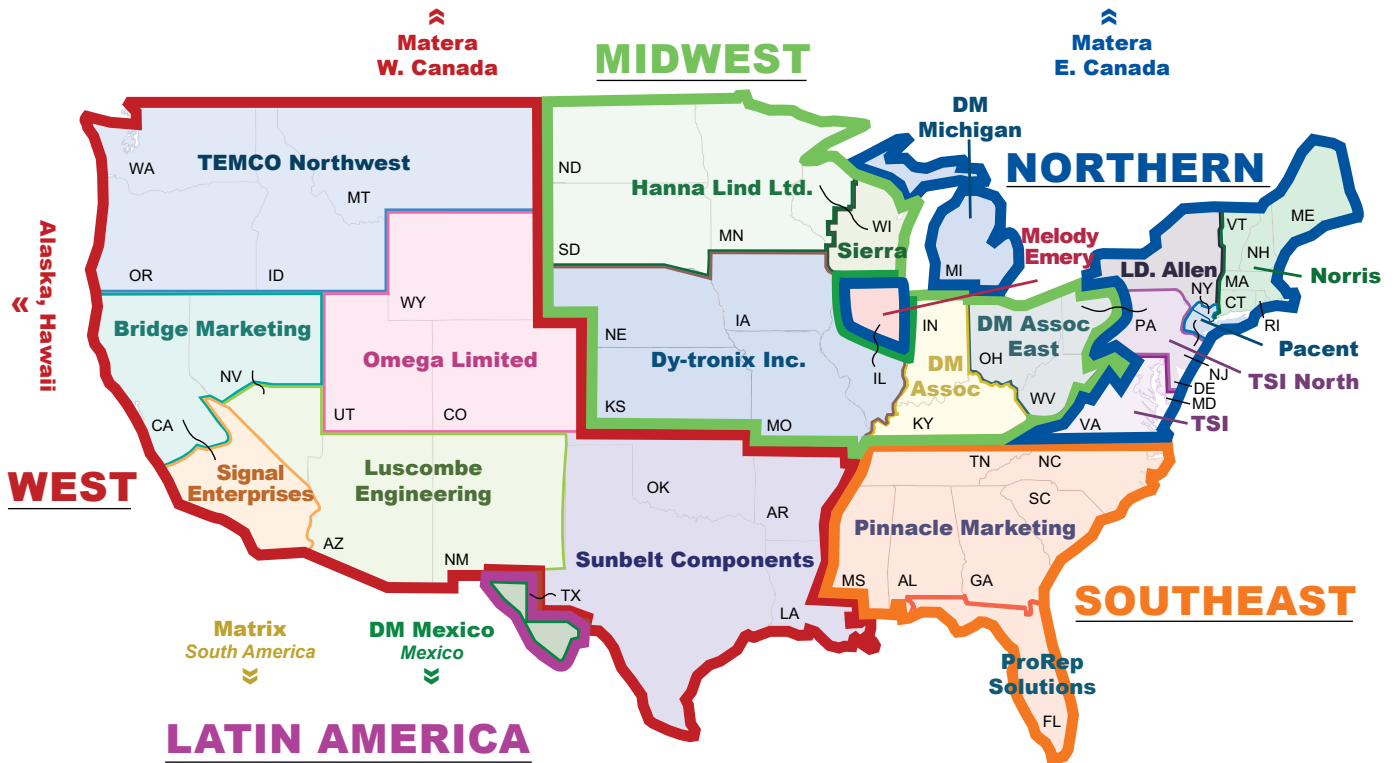

Americas



Europe  
Middle East  
Africa



Asia-Pacific  
Oceania

## About Carling

Founded in 1920, Carling Technologies is a leading manufacturer of electrical and electronic switches and assemblies, circuit breakers, electronic controls, power distribution units, and multiplexed power distribution systems. With four ISO registered manufacturing facilities and technical sales offices worldwide, Carling Technologies Sales, Service and Engineering teams do much more than manufacture electrical components, they engineer powerful solutions! To learn more about Carling please visit [www.carlingtech.com/company-profile](http://www.carlingtech.com/company-profile).

To view all of Carling’s environmental, quality, health & safety certifications please visit [www.carlingtech.com/environmental-certifications](http://www.carlingtech.com/environmental-certifications)

## **Worldwide Headquarters**

Carling Technologies, Inc.  
60 Johnson Avenue, Plainville, CT 06062  
**Phone:** 860.793.9281 **Fax:** 860.793.9231  
**Email:** sales@carlingtech.com

**Northern Region Sales Office:** nrsm@carlingtech.com  
**Southeast Region Sales Office:** sersm@carlingtech.com  
**Midwest Region Sales Office:** mrrsm@carlingtech.com  
**West Region Sales Office:** wrsm@carlingtech.com  
**Latin America Sales Office:** larsm@carlingtech.com

## **Asia-Pacific Headquarters**

Carling Technologies, Asia-Pacific Ltd.,  
Kowloon, Hong Kong  
**Phone:** Int + 852-2737-2277 **Fax:** Int + 852-2736-9332  
**Email:** sales@carlingtech.com.hk

**Shenzhen, China:** shenzhen@carlingtech.com  
**Shanghai, China:** shanghai@carlingtech.com  
**Pune, India:** india@carlingtech.com  
**Kaohsiung, Taiwan:** taiwan@carlingtech.com  
**Yokohama, Japan:** japan@carlingtech.com

## **Europe | Middle East | Africa Headquarters**

Carling Technologies LTD  
4 Airport Business Park, Exeter Airport,  
Clyst Honiton, Exeter, Devon, EX5 2UL, UK  
**Phone:** Int + 44 1392.364422 **Fax:** Int + 44 1392.364477  
**Email:** ltd.sales@carlingtech.com

**Germany:** gmbh@carlingtech.com  
**France:** sas@carlingtech.com



**Carling Technologies™**

Innovative Designs. Powerful Solutions.