

THIS DRAWING IS UNPUBLISHED. RELEASED FOR PUBLICATION 20
 © COPYRIGHT 20 BY - ALL RIGHTS RESERVED.

REVISIONS					
P	LTR	DESCRIPTION	DATE	DWN	APVD
A		INITIAL RELEASE	16DEC2014	HMR	CW
B		ECR-15-013292	16SEP2015	DL	CW
C		ECR-18-016084	13OCT2018	GY	CW

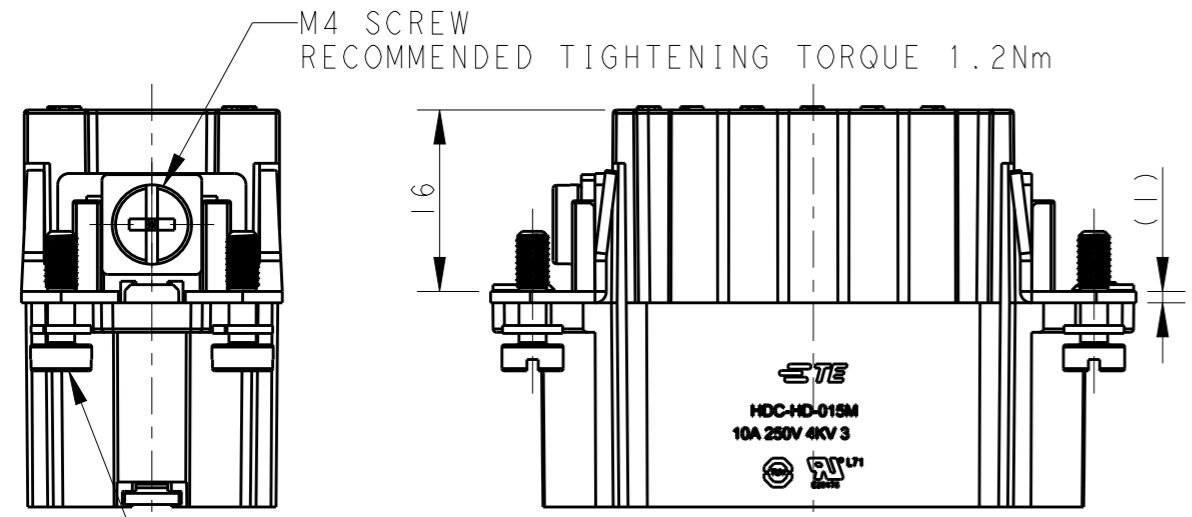

4-M3 SCREW
 RECOMMENDED TIGHTENING TORQUE 0.5Nm

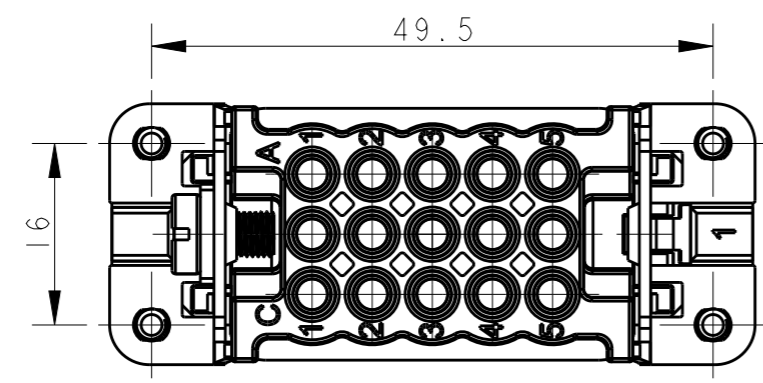
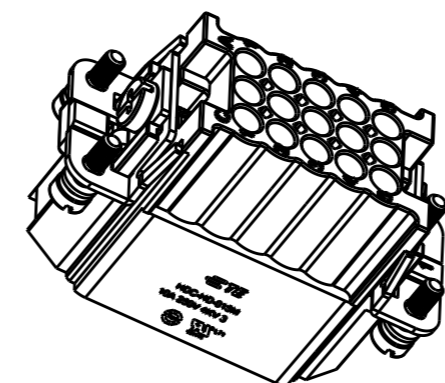
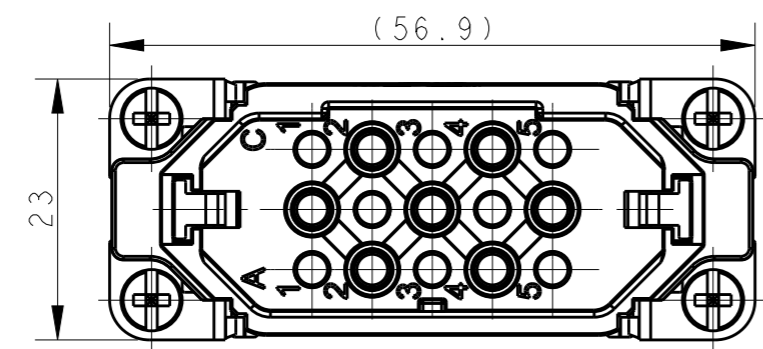

SCALE 1:1

NOTES:
 1. TECHNICAL CHARACTERISTICS:
 INSULATION MATERIAL: PC
 RATED VOLTAGE: 250 V
 RATED CURRENT: 10 A
 INSULATION RESISTANCE: $\geq 400M\Omega$
 RATED IMPULSE VOLTAGE: 4 KV
 POLLUTION DEGREE: 3
 FLAMMABILITY: UL94V-0
 MATING CYCLES: 500 CYCLES
 OPERATION TEMPERATURE: $-40-+125^{\circ}C$
 WIRE RANGE: 0.14-2.5 mm² (26-14 AWG)
 CONTACT TYPE: CRIMP CONTACT
 2. CONTACT NEED TO BE ORDERED SEPARATELY.
 (ORDER No. REFER TO DRAWING: T20200X10XX000)

注释:
 1. 技术参数:
 绝缘材料: PC
 额定电压: 250V
 额定电流: 10A
 绝缘电阻: $\geq 400M\Omega$
 额定脉冲电压: 4 KV
 污染等级: 3
 阻燃等级: UL94V-0
 插拔次数: 500次
 工作温度: $-40-+125^{\circ}C$
 接线范围: 0.14-2.5 mm² (26-14 AWG)
 接线类型: 冷压接
 2. 端子需要单独订购.
 (订货号参考图面: T20200X10XX000)

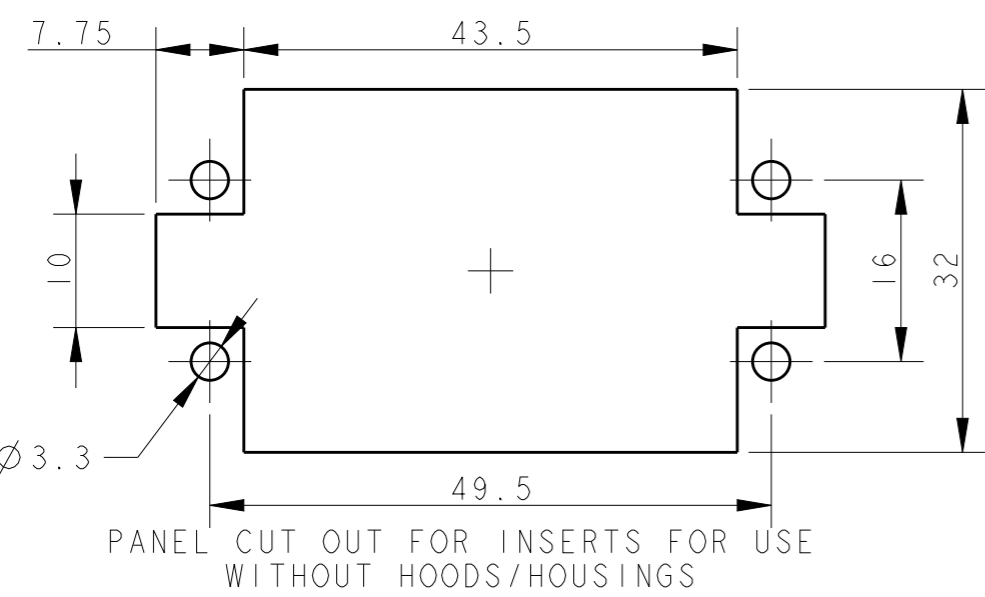

T2020152101-000	HD-015-M	HD-015 MALE INSERT HD-015公插
PART NUMBER 零件料号	PART DESCRIPTION 零件描述	

THIS DRAWING IS A CONTROLLED DOCUMENT.		DWN 16DEC2014 RAGHAVENDRA H M	STE TE Connectivity	
DIMENSIONS: mm		CHK 16DEC2014 CHRIS WANG		
TOLERANCES UNLESS OTHERWISE SPECIFIED:		APVD 16DEC2014 XU XIANG	NAME HD-015-M	
0 PLC ±.015		PRODUCT SPEC 108-137042	SIZE A3	
1 PLC ±.015		APPLICATION SPEC 114-137042	CAGE CODE -	DRAWING NO T2020152101000
2 PLC ±.015		WEIGHT -	RESTRICTED TO	
3 PLC ±.015		CUSTOMER DRAWING	SCALE 3:2	
4 PLC ±.015			SHEET 1 OF 1	
ANGLES ±.015			REV C	
FINISH				