

### INTRODUCTIONS

1. Designed to meet globally accepted IEC publication 320 Class 1, that allows users to comply with industry standard in power entry requirement.
2. Connector for cold condition, with pin temperature 70°C max.
3. Nickel-plated brass pins for soldering on PC board.
4. SK-1010: UL, CSA, VDE, CCC approved.  
SK-1019: UL, CSA, VDE, CCC approved.  
SK-1013: UL, CSA approved.

### SPECIFICATIONS

1. Rated voltage: 250VAC
2. Minimum insulation resistance at 500VDC: 10M OHM
3. Dielectric strength (one minute): 2000VAC between pins
4. Flammability class: UL 94V-0

### MECHANICAL CONSTRUCTION



SK-1010

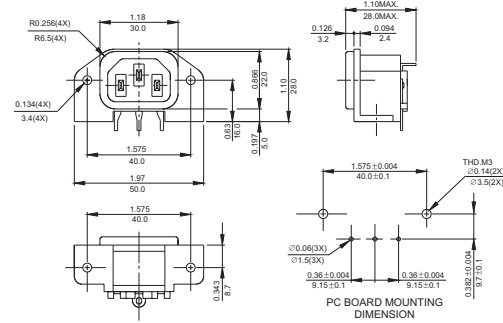

SK-1013

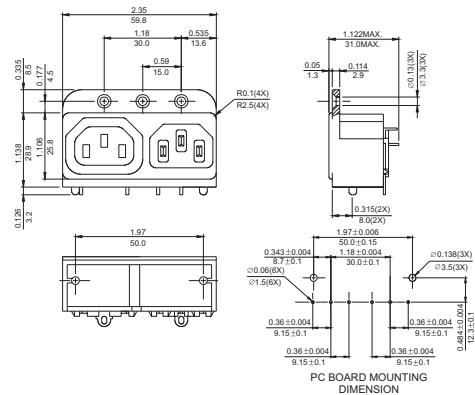

SK-1019

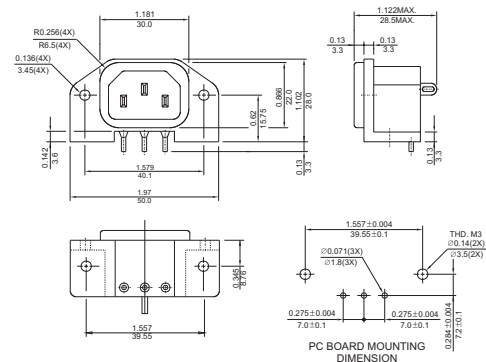

UNIT: INCH  
mm