

DATE	DESCRIPTION	REV.
9.17.04	CHANGE AS PER ECN 04-107	B
11.04.11	CHANGE AS PER ECN 11-149	C

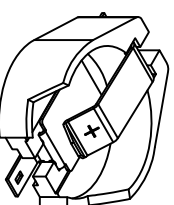
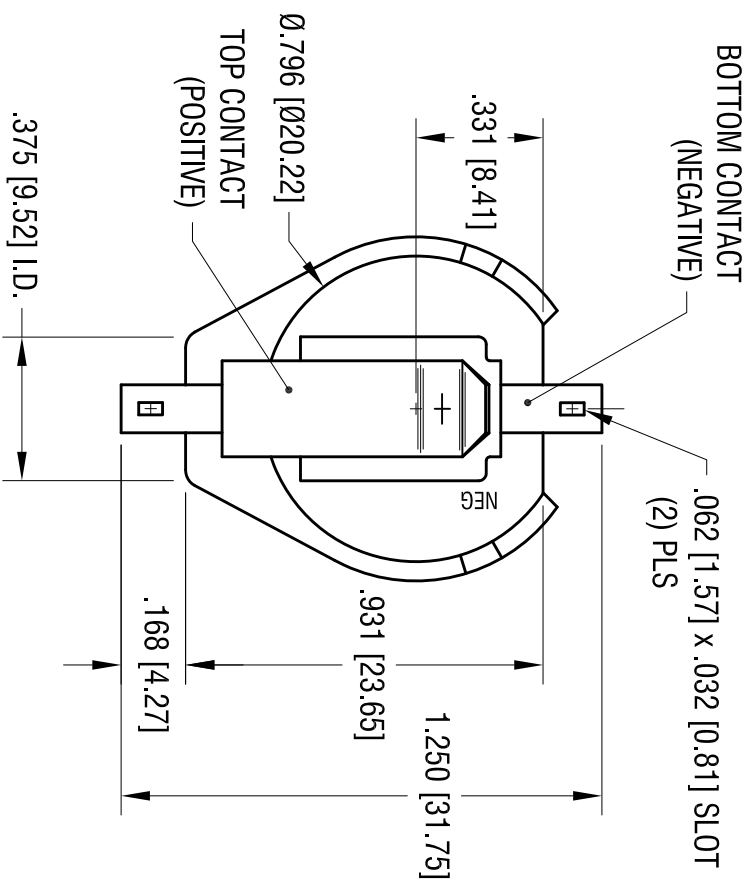
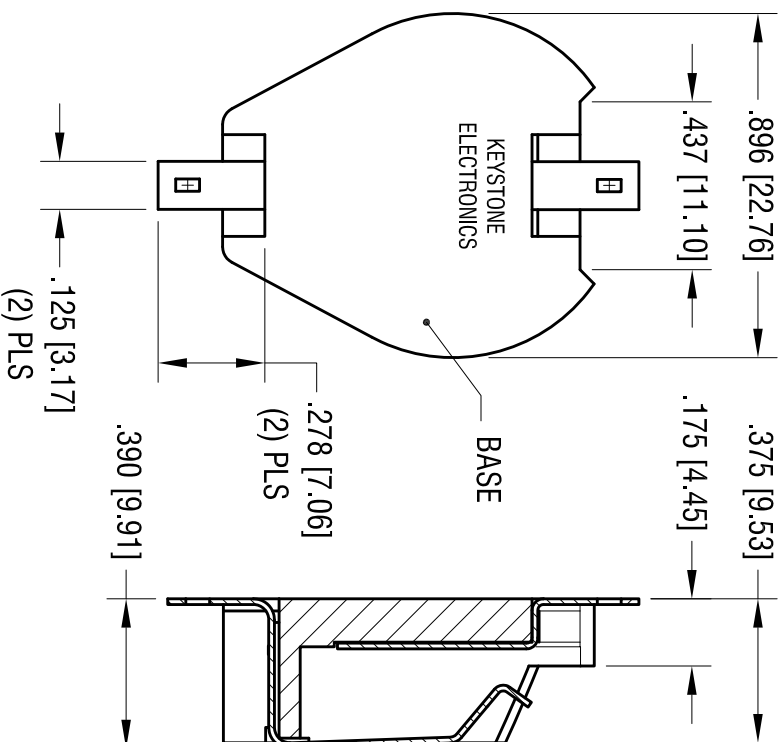
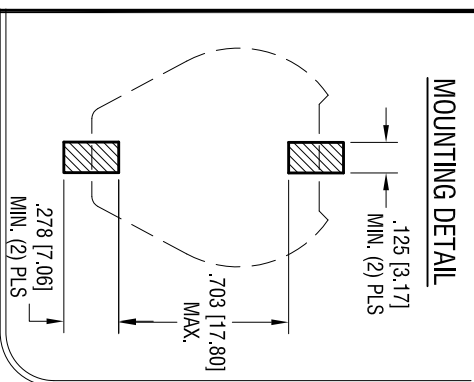

ACTUAL SIZE

THIS DOCUMENT IS THE PROPERTY OF KEYSTONE ELECTRONICS CORP. AND SHALL NOT BE REPRODUCED, DISTRIBUTED OR USED AS A BASIS FOR MANUFACTURE WITHOUT PRIOR WRITTEN PERMISSION FROM KEYSTONE ELECTRONICS CORP.

**KEYSTONE ELECTRONICS CORP.**  
 www.keystelco.com • ASTORIA, N.Y. 11105-2017 • Tel (718) 956-8900

PART NAME: DUAL 20mm BATTERY HOLDER, SMT  
 MATERIAL: AS NOTED

FINISH: AS NOTED  
 DRN BY: BOONE  
 DATE: 8.9.95

App'd: LN  
 SCALE: 2X  
 TOLERANCES: INCH [MM]  
 DECIMAL ± .010 [± 0.25]  
 ANGULAR ± 1°  
 CODE: C  
 DWG NO.: 1064

- NOTES:
1. BASE:  
 MAT'L - HIGH TEMPERATURE NYLON (UL 94V-0)  
 COLOR BLACK
  2. CONTACTS (TOP AND BOTTOM):  
 MAT'L - .015 [0.38] THK SPRING STEEL  
 FINISH: TIN NICKEL PLATE