

# EVERY DENNISON MARKETING SPECIFICATION

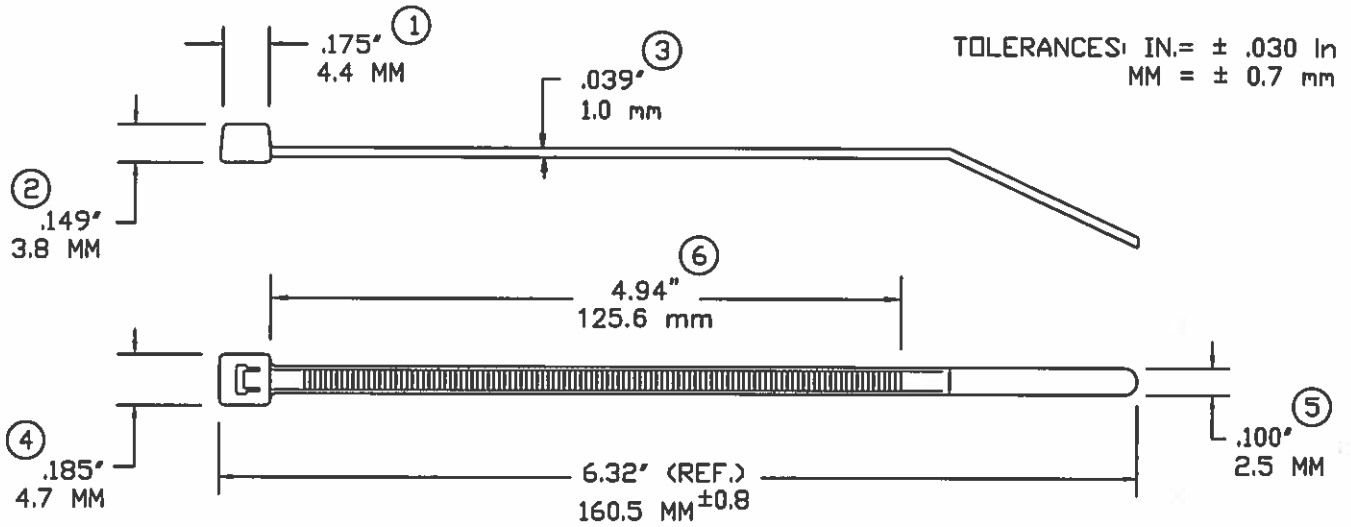

NOT TO SCALE

LOOPED TENSILE STRENGTH:	18 Lbsf. / 80N MINIMUM
MILITARY STANDARD:	N/A
MATERIAL:	NYLON 6/6
WEIGHT:	.01363 OZ. / .40 GRAMS
BUNDLE DIAMETER:	Ø0.063"/1.59mm TO 1.5"/38.1mm
MIN. INSTALLATION TEMP:	32°F (0°C)
OPERATING TEMPERATURE:	-40°F(-40°C) TO 220°F(105°C)
APPLICATION TOOL:	TOOL, HAND ADJUSTABLE, FOR PLASTIC TIE DOWN STRAP. AVERY DENNISON PART NUMBER 12001.
TOOL TENSION SETTING:	1-3
PACKAGED IN:	1000 PACKS IN SEALED BAGS (100 PACKS AVAILABLE)

Plenum rated and has a flammability rating of V-2  
UL applications require use within enclosures

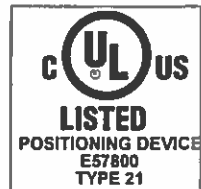

FASTENER DIVISION  
FITCHBURG, MA 01420 U.S.A.  
TEL. 1-800-225-5913  
MA. 978-353-8157

DESCRIPTION:

6" CABLE TIE, SLIM-LINE  
BLACK HEAT STABILIZED

APPROVAL:

*Jinda Boyd 4/1/2016*

STOCK NO. 10392-0

REV  
K