

PART NAME: KNOB

SCALE: 1:1

DATE: 4/18/45

DR. BY JWC

DAVIES MOLDING COMPANY
CAROL STREAM, ILLINOIS 60188

P/N 1450-G

THIS DRAWING IS THE PROPERTY OF DAVIES MOLDING COMPANY, IS SUBMITTED SOLELY AS A DESIGN OR ENGINEERING PROJECT.
WE ACCEPT NO RESPONSIBILITY WHATSOEVER FOR THE PRACTICAL APPLICATION OF THE PIECES MADE TO THIS DESIGN.

BASE PART 1450-07

SET SCREW I0357

SCALE 2:1

KNURL 60 SEPRATION
EQUALLY SPACED AT 6° APART

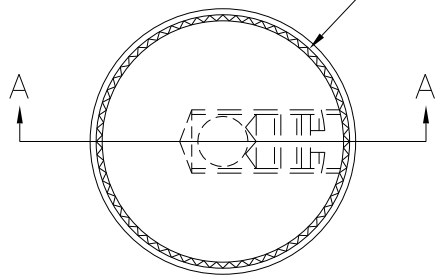

(B)

SECTION A-A

USE # 28 DRILL (ø0.140), #8-32 TAP,
#8-32 X 1/4 LG. CUP POINTED,
SLOTTED TYPE, SET SCREW, I0357.

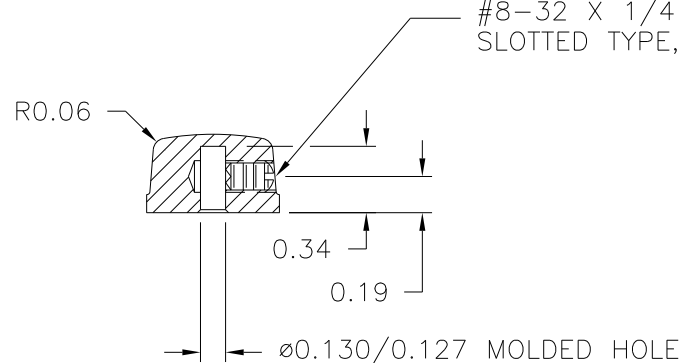
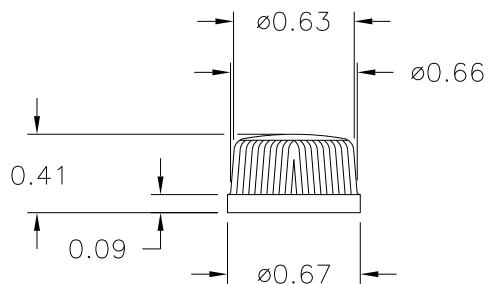

(B)

(A)

MATERIAL: G.P. PHENOLIC (B11)
COLOR: BLACK

TOLERANCES: UNLESS OTHERWISE SPECIFIED	DO NOT SCALE DRAWING	-	UPDATED/HAD TOOLBOX	ST	7/28/2000
DECIMALS: X.XXX ± .005 X.XX ± .015	MM: X.XX ± 0.15MM X.X ± 0.4MM	B	WAS I0027	MS	1/16/57
FRACTIONS ± 1/64	ANG. ± 1°	A	DELETED #6-32 TAP	JWC	5/1/45
CHANGES					

PART NAME: KNOB SCALE: 1:1 DATE: 4/18/45 DR. BY JWC

DAVIES MOLDING COMPANY
CAROL STREAM, ILLINOIS 60188

P/N 1450-G

THIS DRAWING IS THE PROPERTY OF DAVIES MOLDING COMPANY, IS SUBMITTED SOLELY AS A DESIGN OR ENGINEERING PROJECT.
WE ACCEPT NO RESPONSIBILITY WHATSOEVER FOR THE PRACTICAL APPLICATION OF THE PIECES MADE TO THIS DESIGN.

BASE PART 1450-07

SET SCREW I0357

SCALE 2:1

KNURL 60 SEPRATION
EQUALLY SPACED AT 6° APART

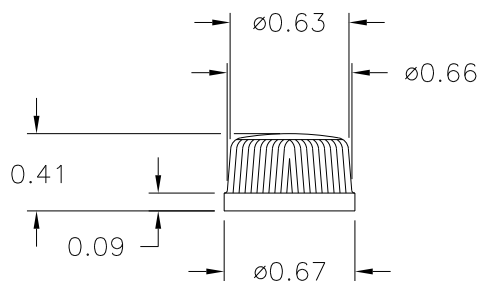
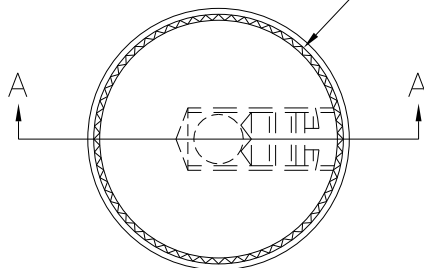

SECTION A-A

USE # 28 DRILL ($\phi 0.140$), #8-32 TAP,
#8-32 X 1/4 LG. CUP POINTED,
SLOTTED TYPE, SET SCREW, I0357.

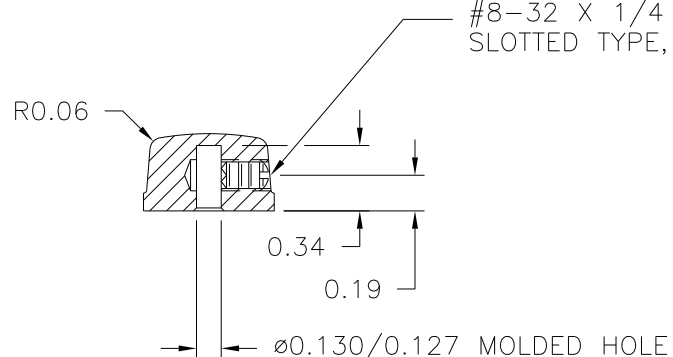

MATERIAL: G.P. PHENOLIC (B11)
COLOR: BLACK

TOLERANCES: UNLESS OTHERWISE SPECIFIED	DO NOT SCALE DRAWING	-	UPDATED/HAD TOOLBOX	ST	7/28/2000
DECIMALS: X.XXX ± .005 X.XX ± .015	MM: X.XX ± 0.15MM X.X ± 0.4MM	B	WAS I0027	MS	1/16/57
FRACTIONS ± 1/64	ANG. ± 1°	A	DELETED #6-32 TAP	JWC	5/1/45
CHANGES					