

AVERY DENNISON MARKETING SPECIFICATION

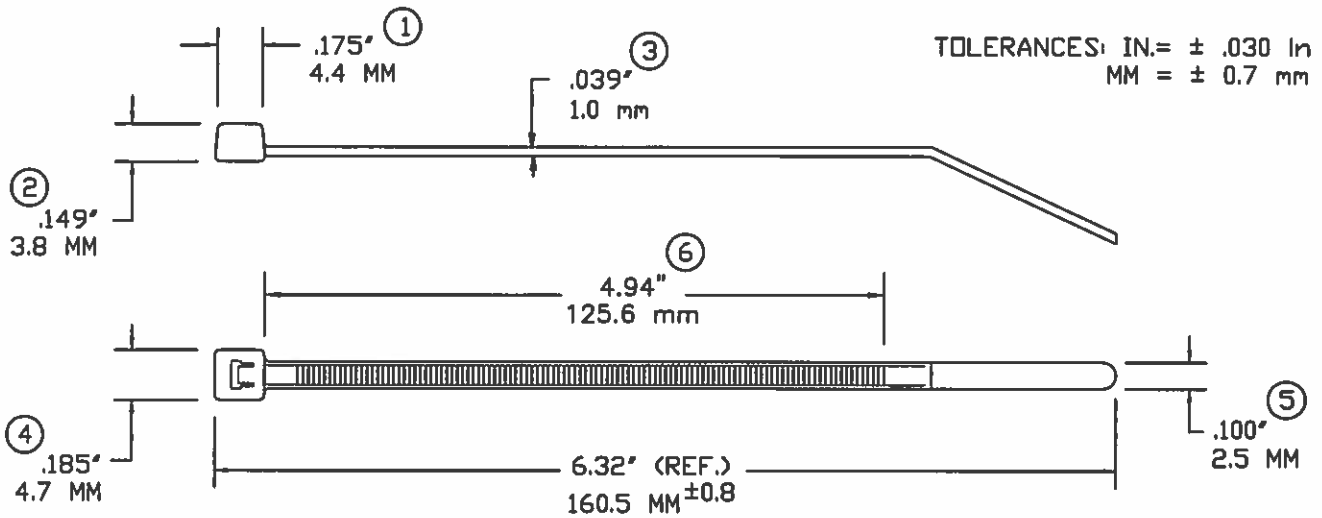

NOT TO SCALE

| | |
|--------------------------|--|
| LOOPED TENSILE STRENGTH: | 18 Lbsf. / 80N MINIMUM |
| MILITARY STANDARD: | MS-3367-4-0 |
| MATERIAL: | NYLON 6/6 |
| WEIGHT: | .01363 OZ. / .40 GRAMS |
| BUNDLE DIAMETER: | ∅0.063"/1.59mm TO 1.5"/38.1mm |
| MIN. INSTALLATION TEMP: | 32°F (0°C) |
| OPERATING TEMPERATURE: | -40°F(-40°C) TO 176°F(80°C) |
| APPLICATION TOOL: | TOOL, HAND ADJUSTABLE, FOR PLASTIC TIE DOWN STRAP. AVERY DENNISON PART NUMBER 12001. |
| TOOL TENSION SETTING: | 1-3 |
| PACKAGED IN: | 1000 PACKS IN SEALED BAGS (100 PACKS AVAILABLE) |

UV Resistant and has a flammability rating of V-2
For use indoors and outdoors



FASTENER DIVISION
FITCHBURG, MA 01420 U.S.A.
TEL 1-800-225-5913
MA. 978-353-8157

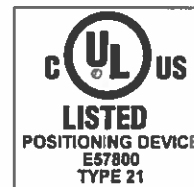

DESCRIPTION:

**6" CABLE TIE, SLIM-LINE
BLACK WEATHER RESISTANT**

APPROVAL:

Jurda Boyle 4/1/2016

STOCK NO. 10393-0

REV
J