

# QUICK START GUIDE FOR DEMONSTRATION CIRCUIT 1292 NO RSENSE STEP-DOWN DC/DC CONVERTER

## LTC3878EGN

### DESCRIPTION

Demonstration circuit 1292 is a NO RSENSE STEP-DOWN DC/DC CONVERTER featuring the LTC3878EGN. Its output supplies 1.2V @ 18A and its input voltage range is 4.5V to 14V. The demo board uses a high density, two sided drop-in layout. The power components, excluding the bulk output capacitors and bulk input capacitors, fit within a 0.94" x 0.63" area on the top layer. The control circuit on the bottom layer has a footprint of 0.63" x 0.40".

The fixed on-time valley current mode architecture of the LTC3878EGN provides a very fast load step response. Other features of the board include a RUN/SS pin, a PGOOD pin and jumper to select either CCM or DCM operation at light load.

**Design files for this circuit board are available. Call the LTC factory.**

PowerPath is a trademark of Linear Technology Corporation

**Table 1. Performance Summary (T<sub>A</sub> = 25°C)**

PARAMETER	CONDITION	VALUE
Minimum Input Voltage		4.5V
Maximum Input Voltage		14V
Output Voltage	V <sub>IN</sub> = 4.5V to 14V, I <sub>OUT</sub> = 0A to 18A	1.2V ±2%
Maximum Output Current		18A
Typical Output Voltage Ripple	V <sub>IN</sub> = 12V, I <sub>OUT</sub> = 18A (20MHz BW)	17mVp-p
Nominal Switching Frequency	100% load, V <sub>IN</sub> = 12V, I <sub>OUT</sub> = 18A	340kHz
Efficiency (see Figure 3 for efficiency curves)	V <sub>IN</sub> = 12V, 100% load	88.4% Typical

### QUICK START PROCEDURE

Demonstration circuit 1292 is easy to set up to evaluate the performance of the LTC3878EGN. Refer to Figure 1 for proper measurement equipment setup and follow the procedure below:

**NOTE:** When measuring the input or output voltage ripple, care must be taken to avoid a long ground lead on the oscilloscope probe. See Figure 2 for proper scope probe technique. Short, stiff leads should be soldered to the (+) and (-) terminals of an output capacitor. The probe's ground ring needs to touch the (-) lead and the probe tip needs to touch the (+) lead.

1. Place jumpers in the following positions:  
JP1 RUN        ON  
JP2 MODE       CCM
2. With power off, connect the input power supply to Vin and GND.
3. Turn on the power at the input.
4. Check for the proper output voltages.  
V<sub>out</sub> = 1.176V to 1.224V
5. Once the proper output voltages are established, adjust the loads within the operating range and observe the output voltage regulation, ripple voltage, efficiency and other parameters.

# QUICK START GUIDE FOR DEMONSTRATION CIRCUIT 1292

## NO RSENSE STEP-DOWN DC/DC CONVERTER

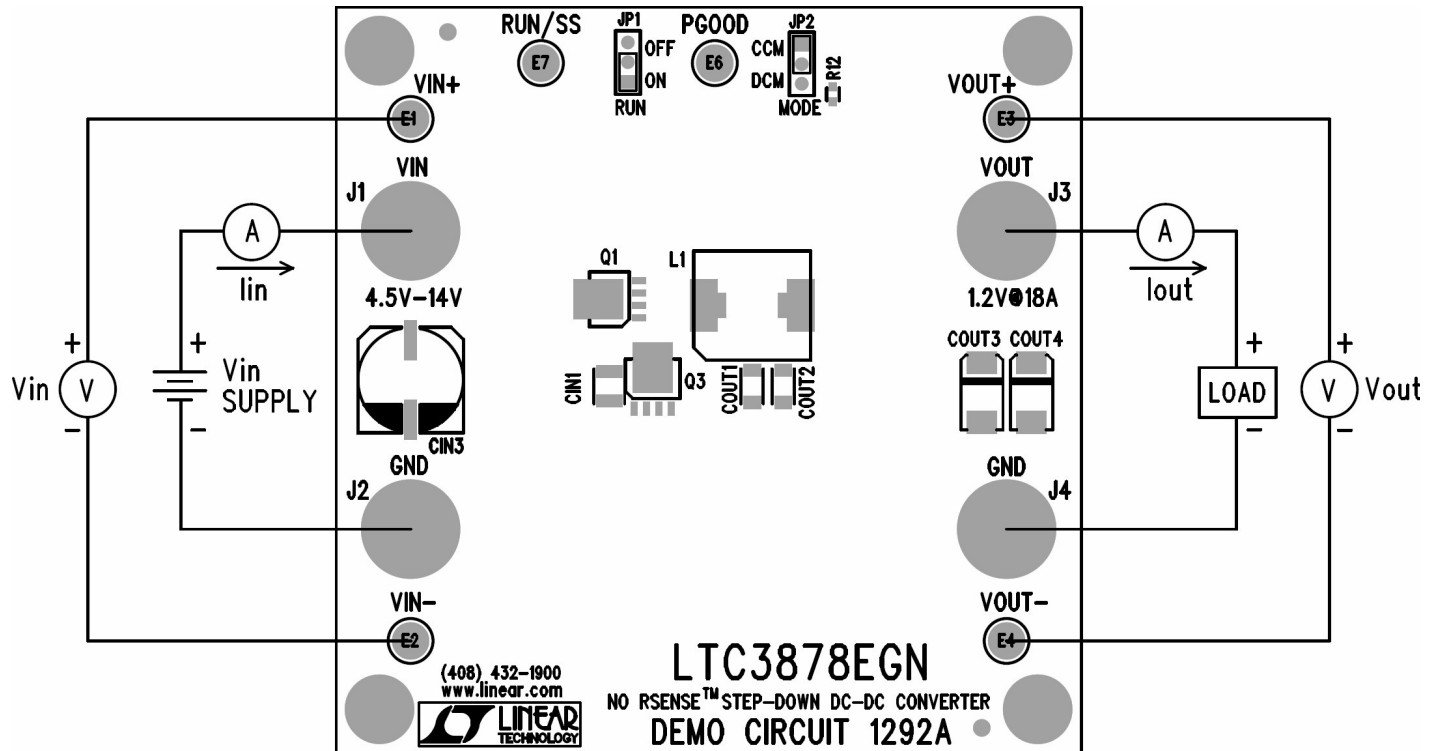

Figure 1. Proper Measurement Equipment Setup

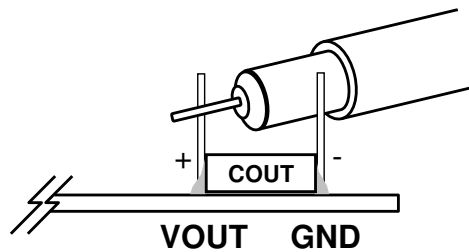

Figure 2. Measuring Output Voltage Ripple

**Fsw = 340kHz, mode = CCM**

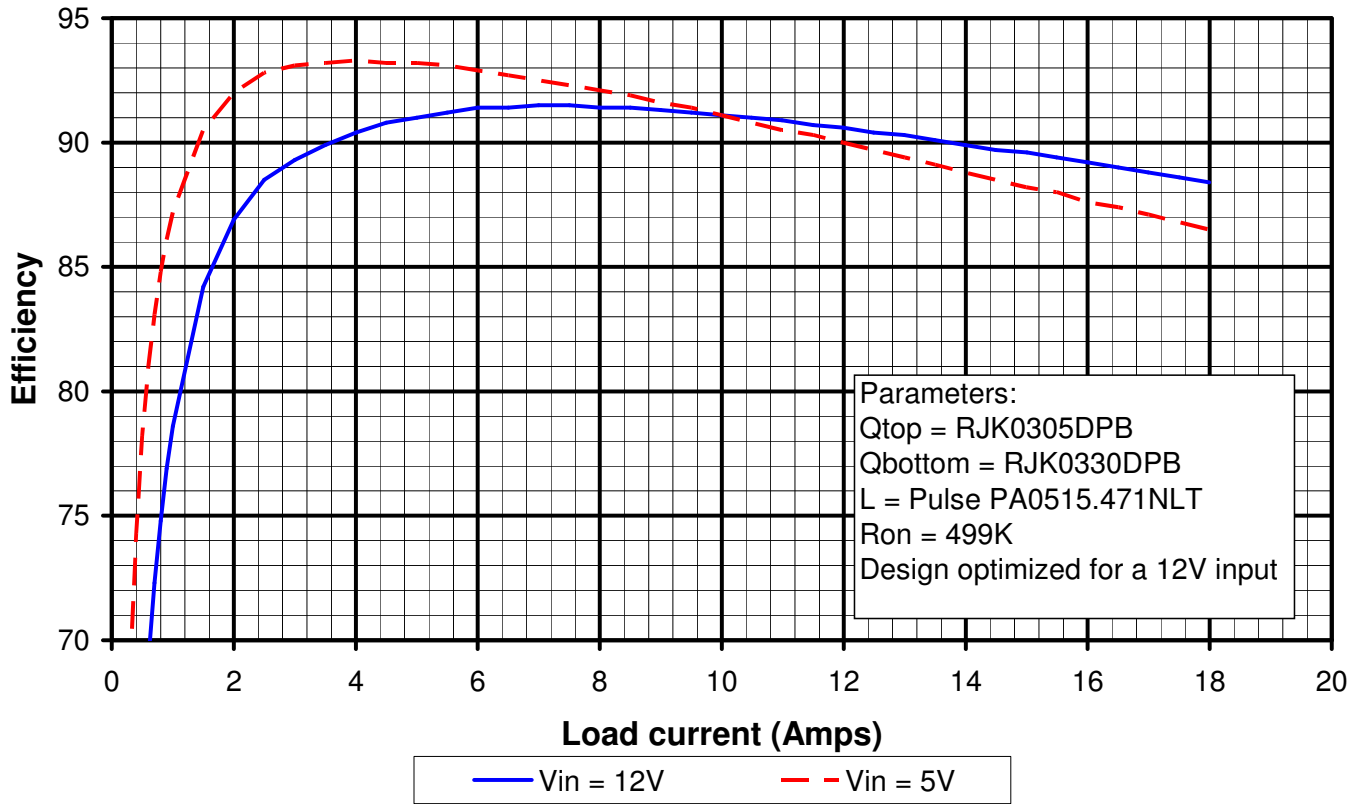
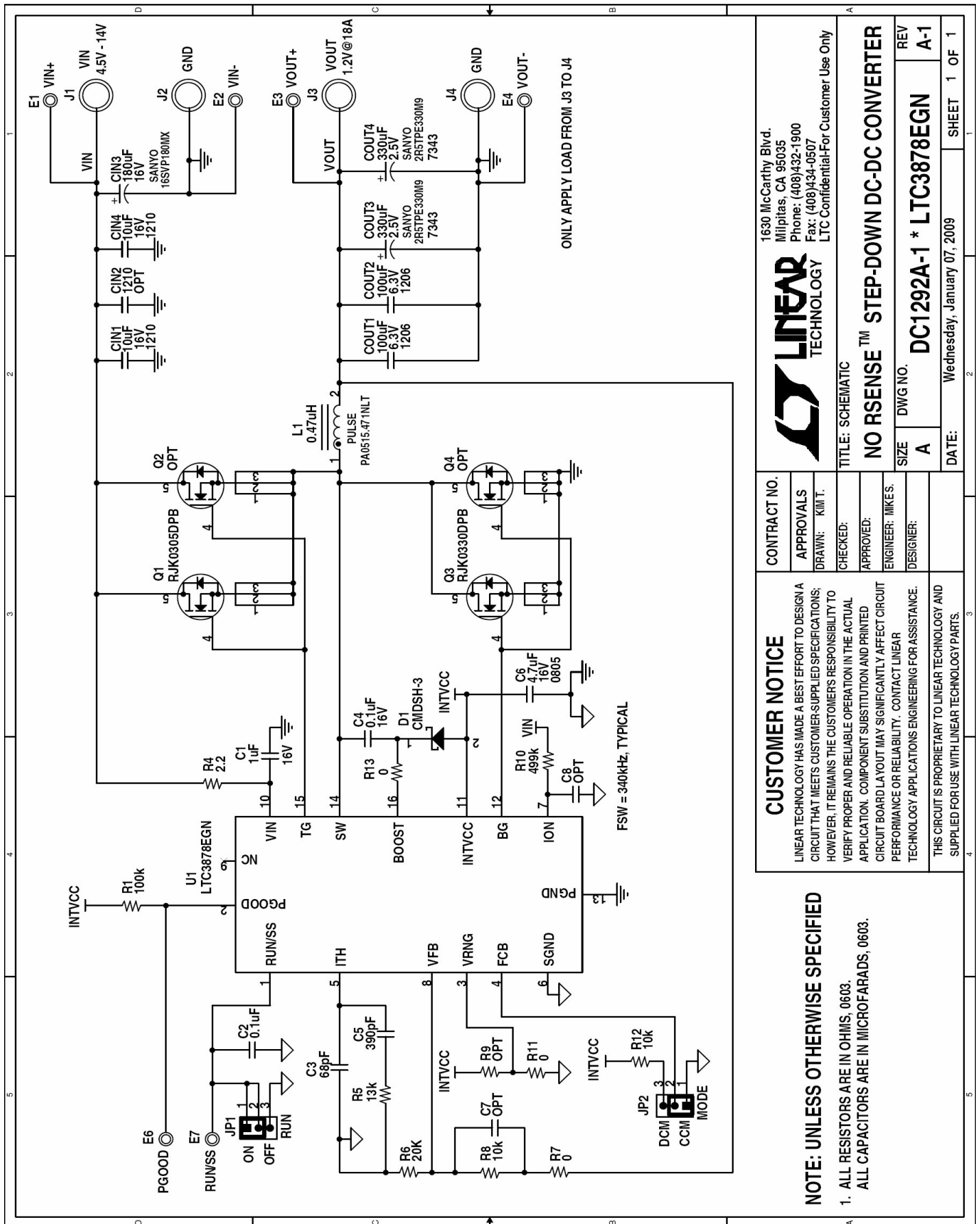

Figure 3. Typical efficiency curves

# QUICK START GUIDE FOR DEMONSTRATION CIRCUIT 1292

## NO RSENSE STEP-DOWN DC/DC CONVERTER



<b>CONTRACT NO.</b> APPROVALS DRAWN: KIM T. CHECKED: APPROVED: ENGINEER: MIKES. DESIGNER:		1630 McCarthy Blvd. Milpitas, CA 95035 Phone: (408)432-1900 Fax: (408)434-0507 LTC Confidential/For Customer Use Only	
<b>CUSTOMER NOTICE</b> LINEAR TECHNOLOGY HAS MADE A BEST EFFORT TO DESIGN A CIRCUIT THAT MEETS CUSTOMER-SUPPLIED SPECIFICATIONS; HOWEVER, IT REMAINS THE CUSTOMER'S RESPONSIBILITY TO VERIFY PROPER AND RELIABLE OPERATION IN THE ACTUAL APPLICATION. COMPONENT SUBSTITUTION AND PRINTED CIRCUIT BOARD LAYOUT MAY SIGNIFICANTLY AFFECT CIRCUIT PERFORMANCE OR RELIABILITY. CONTACT LINEAR TECHNOLOGY APPLICATIONS ENGINEERING FOR ASSISTANCE. THIS CIRCUIT IS PROPRIETARY TO LINEAR TECHNOLOGY AND SUPPLIED FOR USE WITH LINEAR TECHNOLOGY PARTS.		<b>TITLE: SCHEMATIC</b> <b>NO RSENSE™ STEP-DOWN DC-DC CONVERTER</b> SIZE DWG NO. <b>DC1292A-1 * LTC3878EGN</b> REV <b>A-1</b>	
<b>NOTE: UNLESS OTHERWISE SPECIFIED</b> 1. ALL RESISTORS ARE IN OHMS, 0603. ALL CAPACITORS ARE IN MICROFARADS, 0603.		DATE: Wednesday, January 07, 2009 SHEET 1 OF 1	