

THIS DRAWING IS UNPUBLISHED. RELEASED FOR PUBLICATION
 © COPYRIGHT 2007 BY - ALL RIGHTS RESERVED.

REVISIONS					
P	LTR	DESCRIPTION	DATE	DWN	APVD
C	I	Revised documentation ECR-09-002001	28JAN2009	AV	GT
D		Changed spring design	04FEB2010	AV	GT
E		UPDATED PART REVISION	24FEB2011	AV	GT
F		REVISED PER ECR-17-004903	09MAY2017	SK	JL

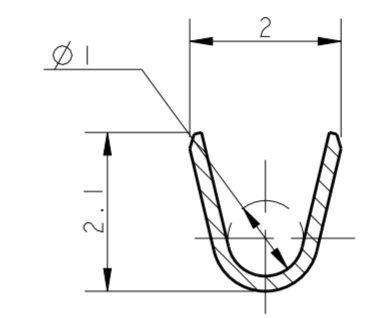

SECTION X - X

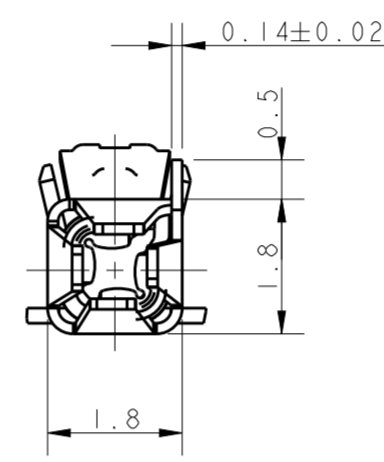
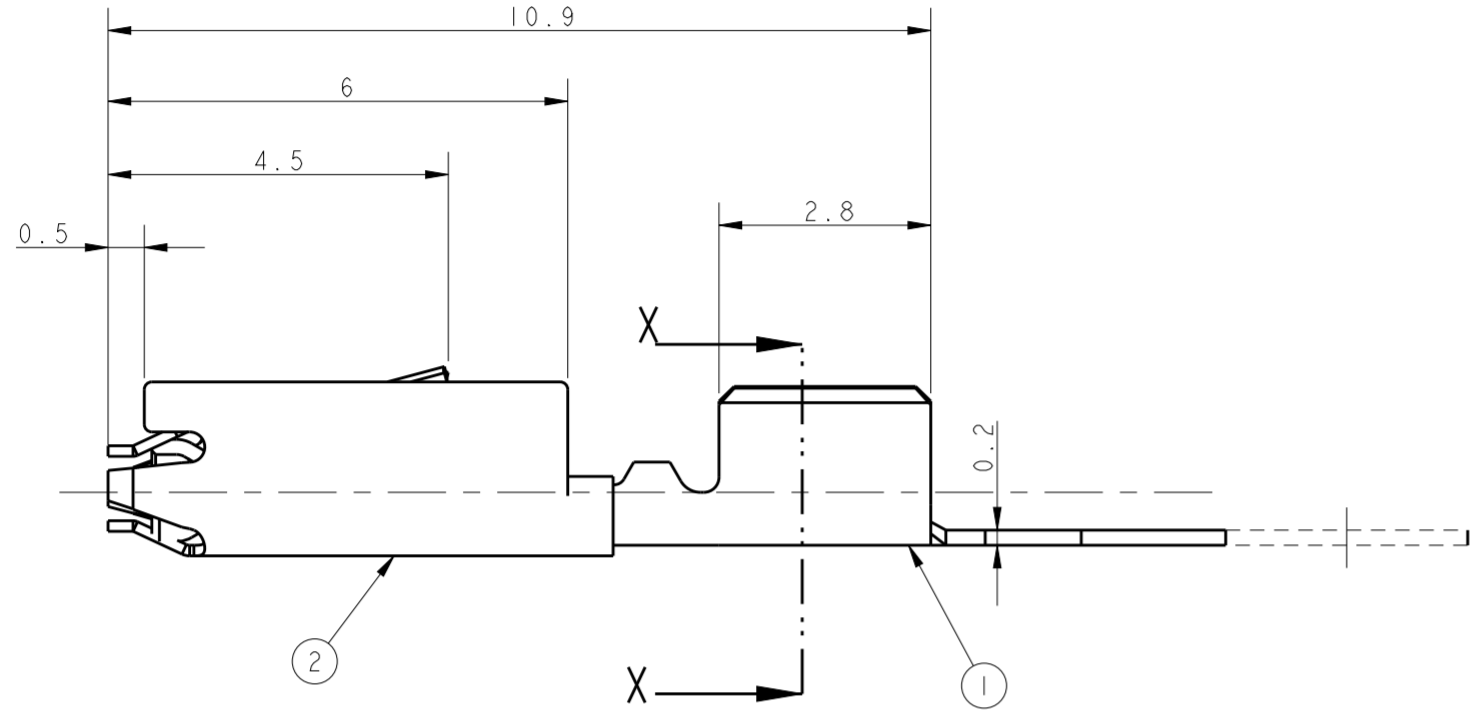
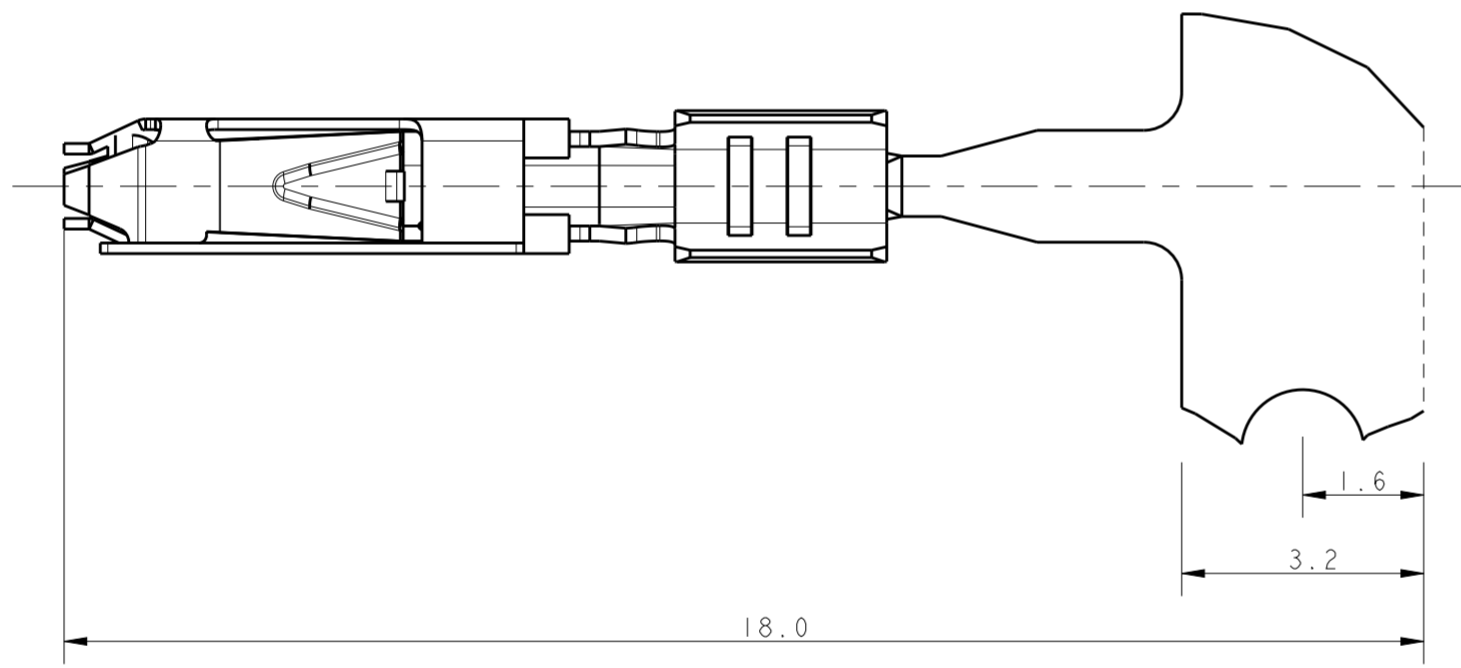

Bemerkungen
NOTES

1. Passend zu Stiftkontakt siehe Zeichnung: AMP: 1740335
SUITABLE FOR PIN CONTACT SEE DRAWING:
2. Kontakt geeignet für Drahtgroessenbereich 0.5...0.75mm²
CONTACT ACCEPTS WIRE-SIZE 0.5...0.75mm²
3. Halbautomatisches Werkzeug und Handzange
(je für 2 crimps in einem Durchgang) verfügbar
SEMI-AUTOMATIC TOOL AND HANDTOOL
(EACH FOR 2 CRIMPS IN ONE CYCLE) AVAILABLE:
4. Abmantellänge für crimp ist 3,5 mm
STRIPPED CABLE LENGTH FOR CRIMP IS 3.5mm
5. Gewicht ca. 0,12g
WEIGHT ABOUT 0.12g
6. Werkzeugvorschub 7,0 mm
DIE FEED 7.0 mm
7. Aufgerollt auf Kartonspule
REELED ON PAPER-REEL

9	1740336-8	1740336-7	E	2	SPRING	X10CrNi 18 8		
				1	BODY	CuNiSi	GOLD PLATED	
9	1740336-6	1740336-4	E	2	SPRING	X10CrNi 18 8		
				1	BODY	CuNiSi	TIN PLATED	
9	1740336-3	1740336-1	E	2	SPRING	X10CrNi 18 8		
				1	BODY	CuNiSi	BLANK	
DIRECTION OFF TOP OF REEL		LOOSE PIECE	PART NO	REV	POS	DESCRIPTION	MATERIAL	FINISH OF CONTACT AREA

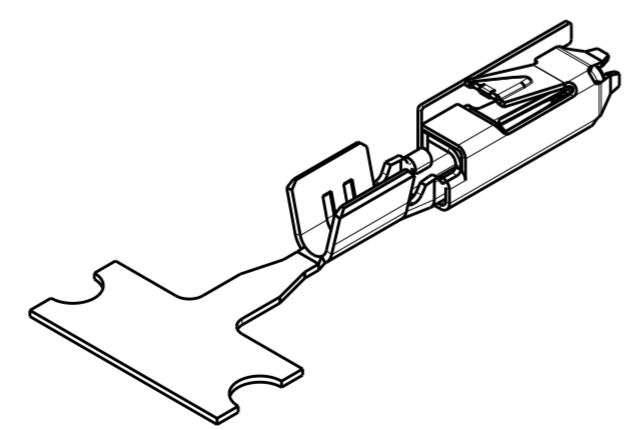

MASSSTAB 5:1

DIRECTION OFF TOP OF REEL	THIS DRAWING IS A CONTROLLED DOCUMENT.		DWN PRAVEEN 24 APR 06	TE Connectivity NAME MICRO QUADLOK SYSTEM SOCKET CONTACT				
	Fertig-zustand	M 1:1	CHK S. SKADE 24 APR 06					APVD T. GERLACH 24 APR 06
	DIMENSIONS: mm 	TOLERANCES UNLESS OTHERWISE SPECIFIED: 0 PLC ± 1 PLC ±0.2 2 PLC ± 3 PLC ± 4 PLC ± ANGLES ± FINISH SEE TABLE	PRODUCT SPEC 108-94018	SIZE	A200779	C-1740336		
MATERIAL SEE TABLE			APPLICATION SPEC 114-18751	WEIGHT			SCALE	10:1
			CUSTOMER DRAWING				SHEET	OF
							REV	F