

MAXIM

3.0V to 5.5V, 2.5Gbps VCSEL and Laser Driver

MAX3996

General Description

The MAX3996 is a high-speed laser driver for small-form-factor (SFF) fiber optic LAN transmitters. It contains a bias generator, a laser modulator, and comprehensive safety features. Automatic power control (APC) adjusts the laser bias current to maintain average optical power, regardless of changes in temperature or laser properties. The driver accommodates common anode or differential laser configurations. The output current range of the MAX3996 is appropriate for VCSELs and high-efficiency edge-emitting lasers.

The MAX3996 operates up to 3.2Gbps. It can switch up to 30mA of laser modulation current and sink up to 60mA bias current. Adjustable temperature compensation is provided to keep the optical extinction ratio within specifications over the operating temperature range. The MAX3996 accommodates various laser packages, including low-cost TO-46 headers. Low deterministic jitter (9ps_{p-p}), combined with fast edge transitions, (65ps) provides excellent margins compared to industry-standard transmitter eye masks.

This laser driver provides extensive safety features to guarantee single-point fault tolerance. Safety features include a transmit disable, redundant shutdown, and laser-bias monitoring. The safety circuit detects faults that could cause hazardous light levels and immediately disables the laser output. The MAX3996 safety circuits are compliant with SFF and small-form-factor pluggable (SFP) multisource agreements (MSA).

The MAX3996 is available in a compact 4mm × 4mm, 20-pin QFN package and a 20-pin thin QFN package. It operates over a temperature range of 0°C to +70°C.

Applications

- Fibre Channel Optical Transmitters
- VCSEL Transmitters
- Gigabit Ethernet Optical Transmitters
- ATM LAN Optical Transmitters
- 10 Gigabit Ethernet WWDM

Pin Configuration appears at end of data sheet.

Features

- ◆ 9ps_{p-p} Deterministic Jitter
- ◆ 20-Pin QFN 4mm × 4mm Package
- ◆ 3.0V to 5.5V Supply Voltage
- ◆ Automatic Power Control
- ◆ Integrated Safety Circuits
- ◆ 30mA Laser Modulation Current
- ◆ Temperature Compensation of Modulation Current
- ◆ Compliant with SFF and SFP MSA

Ordering Information

PART	TEMP RANGE	PIN-PACKAGE	PACKAGE CODE
MAX3996CGP	0°C to +70°C	20 QFN	G2044-3
MAX3996CTP+	0°C to +70°C	20 Thin QFN	T2044-3

+ Denotes Lead-Free Package

Typical Application Circuit

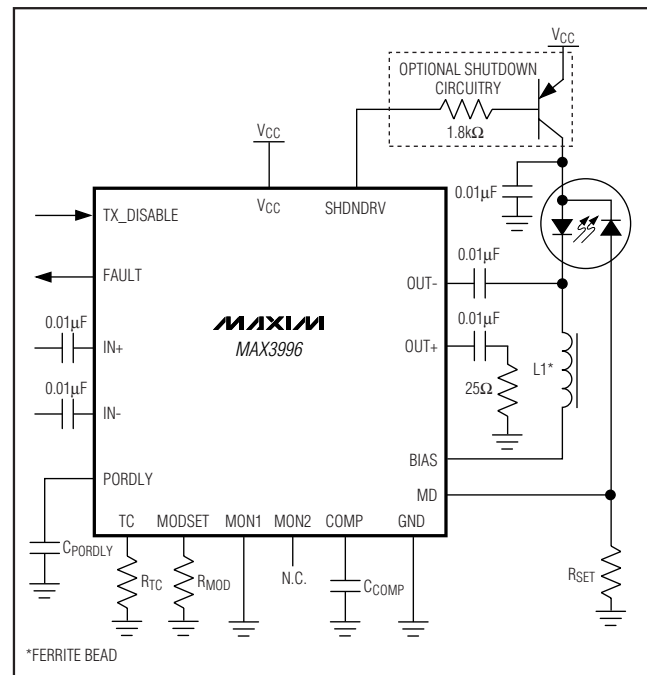

3.0V to 5.5V, 2.5Gbps VCSEL and Laser Driver

ABSOLUTE MAXIMUM RATINGS

Supply Voltage at V_{CC}-0.5V to +7.0V
 Voltage at TX_DISABLE, PORDLY, MON1, COMP,
 IN+, IN-, MD, BIAS, MODSET, TC.....-0.5V to ($V_{CC} + 0.5V$)
 Voltage between COMP and MON22.3V
 Voltage between IN+ and IN-5V
 Voltage at OUT+, OUT-.....($V_{CC} - 2V$) to ($V_{CC} + 2V$)
 Voltage between MON1 and MON21.5V
 Voltage between BIAS and MON2.....4V

Current into FAULT, SHDNDRV-1mA to +25mA
 Current into OUT+, OUT-60mA
 Current into BIAS120mA
 Continuous Power Dissipation ($T_A = +70^{\circ}C$)
 20-Pin QFN (derate 20mW/ $^{\circ}C$).....1600mW
 Operating Ambient Temperature Range-40 $^{\circ}C$ to +85 $^{\circ}C$
 Operating Junction Temperature Range.....-40 $^{\circ}C$ to +150 $^{\circ}C$
 Storage Temperature Range.....-55 $^{\circ}C$ to +150 $^{\circ}C$

Stresses beyond those listed under "Absolute Maximum Ratings" may cause permanent damage to the device. These are stress ratings only, and functional operation of the device at these or any other conditions beyond those indicated in the operational sections of the specifications is not implied. Exposure to absolute maximum rating conditions for extended periods may affect device reliability.

ELECTRICAL CHARACTERISTICS

($V_{CC} = 3.0V$ to $5.5V$, $T_A = 0^{\circ}C$ to $+70^{\circ}C$, unless otherwise noted. Typical values are at $V_{CC} = 3.3V$, TC pin not connected, $T_A = +25^{\circ}C$.) (Figure 1)

PARAMETER	SYMBOL	CONDITIONS	MIN	TYP	MAX	UNITS
Supply Current	I_{CC} (Figure 1) (Note 1)	$V_{CC} = 3.3V$, $I_{MOD} = 15mA$		47		mA
		$V_{CC} = 5.5V$, $I_{MOD} = 30mA$, $R_{MODSET} = 2.37k\Omega$		52	75	
Data Input Voltage Swing	V_{ID}	Total differential signal (Figure 2)	200		2200	mV _{P-P}
TX_DISABLE Input Current		$0 < V_{PIN} < V_{CC}$	-100		+100	μA
TX_DISABLE Input High Voltage	V_{IH}		2.0			V
TX_DISABLE Input Low Voltage	V_{IL}				0.8	V
FAULT Output High Voltage	V_{OH}	$I_{OH} = -100\mu A$, $4.7k\Omega < R_{FAULT} < 10k\Omega$	2.4			V
FAULT Output Low Voltage	V_{OL}	$I_{OL} = 1mA$			0.4	V
BIAS GENERATOR						
Minimum Bias Current	I_{BIAS}	Current into BIAS pin			1	mA
Maximum Bias Current	I_{BIAS}	Current into BIAS pin	60			mA
MD Quiescent Voltage	V_{MD}	APC loop is closed	1.04	1.12		V
		FAULT = high		$V_{CC} - 0.73$		
		TX_DISABLE = high		$V_{CC} - 0.73$		
Monitor Resistance	R_{MON}	(Figure 4)	9.3	11	12.7	Ω
MD Input Current		FAULT = low, TX_DISABLE = low	-3	+0.8	+3	μA
BIAS Current During Fault	I_{BIAS_OFF}				10	μA
APC Time Constant		$C_{COMP} = 0.1\mu F$		35		μs
POWER-ON RESET (POR)						
POR Threshold		Measured at V_{CC}	2.65	2.7	3.0	V
POR Delay	t_{PORDLY}	PORDLY = open (Note 3)	30	55		μs
		$C_{PORDLY} = 0.001\mu F$ (Note 3)	1.7	2.4		ms
POR Hysteresis				20		mV
SHUTDOWN						
Voltage at SHDNDRV		ISHDNDRV = 10 μA , FAULT = high	$V_{CC} - 0.4$			V
		ISHDNDRV = 1mA, FAULT = low		$V_{CC} - 2.4$		
		ISHDNDRV = 15mA, FAULT = low	0	$V_{CC} - 1.2$		
LASER MODULATOR						
Data Rate				< 3.2		Gbps

3.0V to 5.5V, 2.5Gbps VCSEL and Laser Driver

MAX3996

ELECTRICAL CHARACTERISTICS (continued)

($V_{CC} = 3.0V$ to $5.5V$, $T_A = 0^\circ C$ to $+70^\circ C$, unless otherwise noted. Typical values are at $V_{CC} = 3.3V$, TC pin not connected, $T_A = +25^\circ C$.) (Figure 1)

PARAMETER	SYMBOL	CONDITIONS	MIN	TYP	MAX	UNITS
Minimum Modulation Current	i_{MOD}				2	mAp-p
Maximum Modulation Current	i_{MOD}	$R_L \leq 25\Omega$	30	40		mAp-p
Accuracy of Modulation Current (Part-to-Part Variation)		$R_{MODSET} = 2.37k\Omega$ ($i_{MOD} \approx 30mAp-p$ into 25Ω)	-10		+10	%
Edge Transition Time	t_r, t_f	$i_{MOD} = 5mA$ into 25Ω , 20% to 80% (Note 3)		54	100	ps
		$i_{MOD} = 10mA$ into 25Ω , 20% to 80% (Note 3)		55	125	
		$i_{MOD} = 30mA$ into 25Ω , 20% to 80% (Note 3)		65	130	
Deterministic Jitter		$i_{MOD} = 5mA$ into 25Ω (Notes 2, 3)		17	35	psp-p
		$i_{MOD} = 10mA$ into 25Ω (Notes 2, 3)		14	22	
		$i_{MOD} = 30mA$ into 25Ω (Notes 2, 3)		9	20	
Random Jitter		(Note 3)		2	8	psRMS
Modulation Current During Fault	i_{MOD_OFF}			15	200	$\mu Ap-p$
Modulation Current Tempco		Tempco = MAX, $R_{MOD} = open$		4000		ppm/ $^\circ C$
		Tempco = MIN, $R_{TC} = open$		50		
Input Resistance	R_{IN}	Differential	85		115	Ω
Output Resistance	R_{OUT}	Single ended; outputs to V_{CC}	42	50	58	Ω
Input Common-Mode Voltage				$V_{CC} - 0.3$		V
SAFETY FEATURES (See <i>Typical Operating Characteristics</i>)						
MODSET and TC Pin Fault Threshold			200			mV
BIAS Pin Fault Threshold		A fault will be triggered if V_{BIAS} is less than this voltage	300	400		mV
Excessive Bias Current Fault		A fault will be triggered if V_{MON2} exceeds this voltage		400	440	mV
TX Disable Time	t_{off}	Time from rising edge of TX_DISABLE to $I_{BIAS} = I_{BIAS_OFF}$ and $i_{MOD} = i_{MOD_OFF}$ (Note 3)		0.06	5	μs
TX Disable Negate Time	t_{on}	Time from falling edge of TX_DISABLE to I_{BIAS} and i_{MOD} at 95% of steady state (Note 3)		37	500	μs
Reset Initialization Time	t_{init}	From power ON or negation of FAULT using TX_DISABLE. Time to set FAULT = low, $i_{MOD} = 95\%$ of steady state and $I_{BIAS} = 95\%$ of steady state (Note 3)		23	200	ms
Fault Assert Time	t_{fault}	Time from fault to FAULT = high, $C_{FAULT} < 20pF$, $R_{FAULT} = 4.7k\Omega$ (Note 3)		14	50	μs
TX_DISABLE Reset	t_{reset}	Time TX_DISABLE must be held high to reset FAULT (Note 3)		0.01	1	μs

Note 1: Supply current excludes bias and modulation currents.

Note 2: Deterministic jitter is the peak-to-peak deviation from the ideal time crossings measured with a K28.5 bit pattern 00111110101100000101.

Note 3: AC characteristics guaranteed by design and characterization.

3.0V to 5.5V, 2.5Gbps VCSEL and Laser Driver

Typical Operating Characteristics

($V_{CC} = 3.3V$, $T_A = +25^\circ C$, unless otherwise noted.)

ELECTRICAL EYE DIAGRAM
($i_{MOD} = 30mA$, $2^7 - 1$ PRBS, 2.5Gbps)

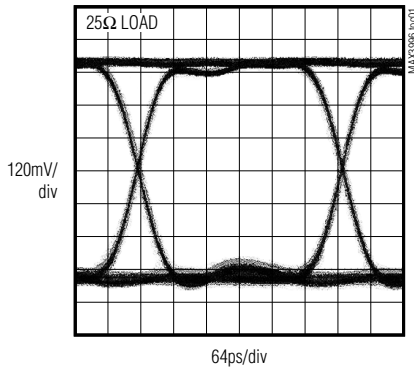

ELECTRICAL EYE DIAGRAM
($i_{MOD} = 30mA$, $2^7 - 1$ PRBS, 3.2Gbps)

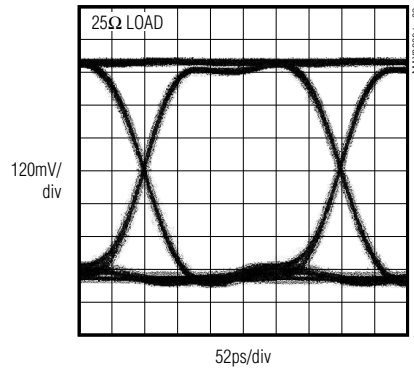

OPTICAL EYE DIAGRAM
($i_{MOD} = 5mA$, 850nm VCSEL, $2^7 - 1$ PRBS, 2.5Gbps, 1870MHz FILTER)

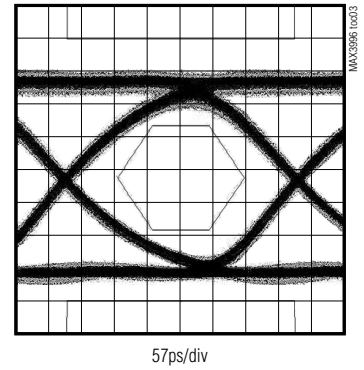

OPTICAL EYE DIAGRAM
($i_{MOD} = 15mA$, 1310nm LASER, $2^7 - 1$ PRBS, 2.5Gbps, 1870MHz FILTER)

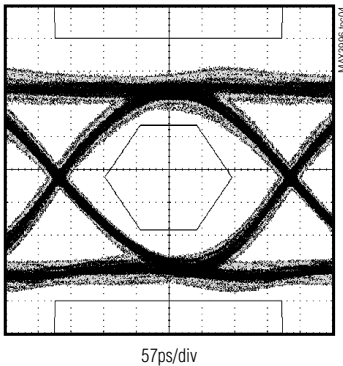

TRANSITION TIME vs. MODULATION CURRENT

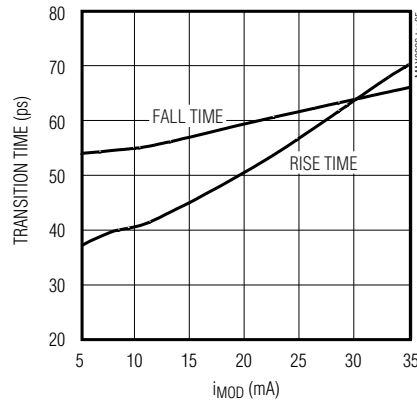

DETERMINISTIC JITTER vs. MODULATION CURRENT

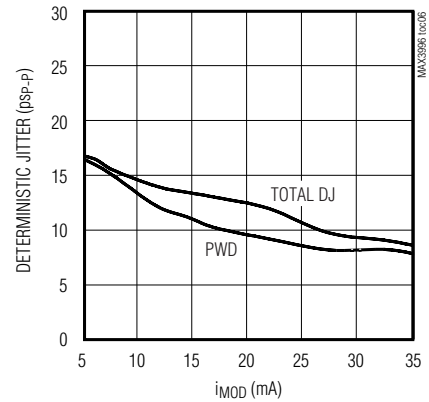

SUPPLY CURRENT vs. TEMPERATURE ($i_{MOD} = 15mA$)

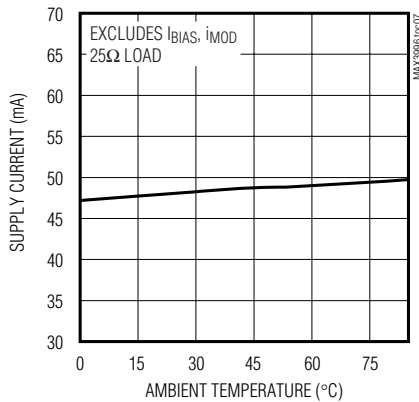

POR DELAY vs. C_{PORDLY}

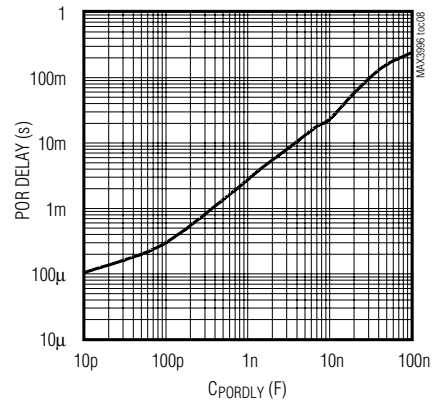

3.0V to 5.5V, 2.5Gbps VCSEL and Laser Driver

MAX3996

Typical Operating Characteristics (continued)

(V_{CC} = 3.3V, T_A = +25°C, unless otherwise noted.)

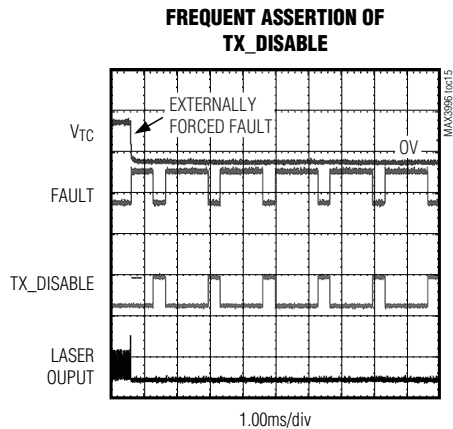
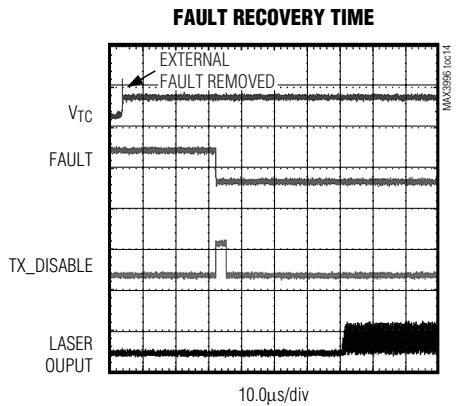
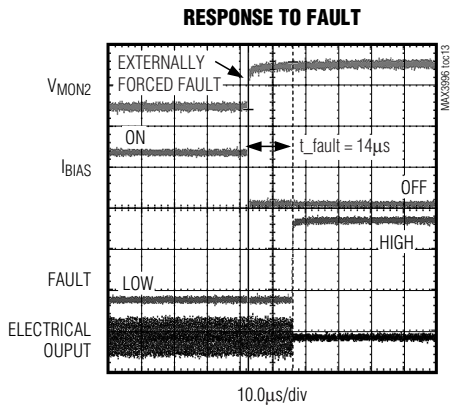
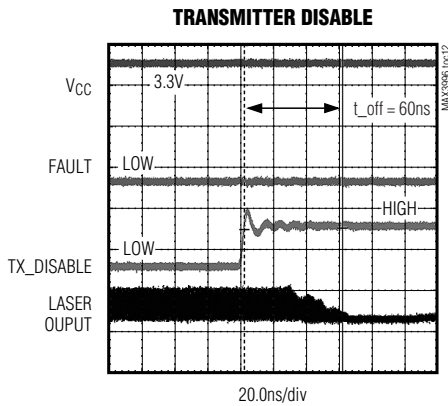
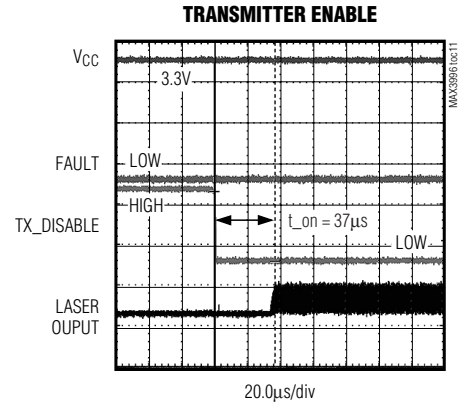
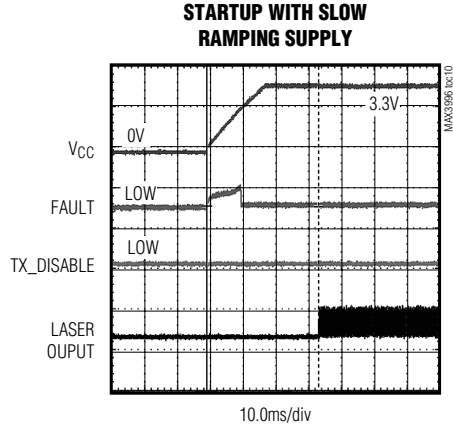
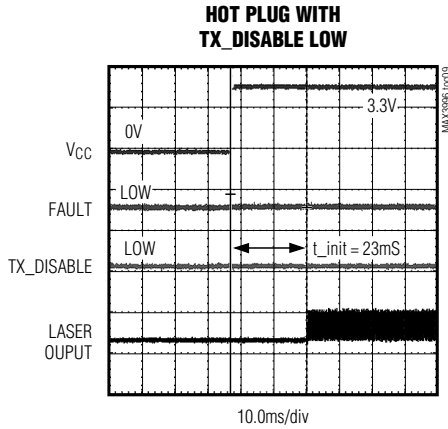

3.0V to 5.5V, 2.5Gbps VCSEL and Laser Driver

Pin Description

PIN	NAME	FUNCTION
1	TC	Temperature Compensation Set. The resistor at TC programs the temperature-increasing component of the laser-modulation current.
2	FAULT	Fault Indicator. See Table 1.
3, 9	GND	Ground
4	TX_DISABLE	Transmit Disable. Laser output is disabled when TX_DISABLE is high or left unconnected. The laser output is enabled when this pin is asserted low.
5	PORDLY	Power-On Reset Delay. A capacitor connected between PORDLY and GND can be used to extend the delay for the power-on reset circuit. See the <i>Design Procedure</i> section.
6, 16, 19	VCC	Supply Voltage
7	IN+	Noninverting Data Input
8	IN-	Inverting Data Input
10	MON1	Attaches to the emitter of the bias driving transistor through a 10 Ω resistor. See the <i>Design Procedure</i> section.
11	MON2	This pin attaches to the emitter of the bias driving transistor. See the <i>Design Procedure</i> section.
12	COMP	A capacitor connected from this pin to ground sets the dominant pole of the APC loop. See the <i>Design Procedure</i> section.
13	MD	Monitor Diode Connection. MD is used for automatic power control.
14	SHDNDRV	Shutdown Driver Output. Provides a redundant laser shutdown.
15	BIAS	Laser Bias Current Output
17	OUT+	Positive Modulation-Current Output. Current flows from this pin when input data is high.
18	OUT-	Negative Modulation-Current Output. Current flows to this pin when input data is high.
20	MODSET	A resistor connected from this pin to ground sets the desired modulation current.
EP	Exposed Pad	Ground. This must be soldered to the circuit board ground for proper thermal and electrical performance. See the <i>Layout Considerations</i> section.

3.0V to 5.5V, 2.5Gbps VCSEL and Laser Driver

MAX3996

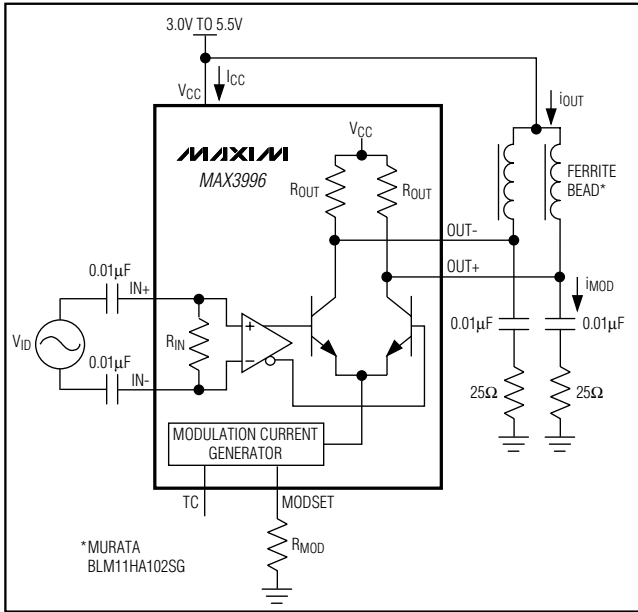

Figure 1. Output Load for AC Specification

Detailed Description

The MAX3996 contains a bias generator with automatic power control and smooth start, a laser modulator, a power-on reset (POR) circuit, and safety circuitry (Figure 3).

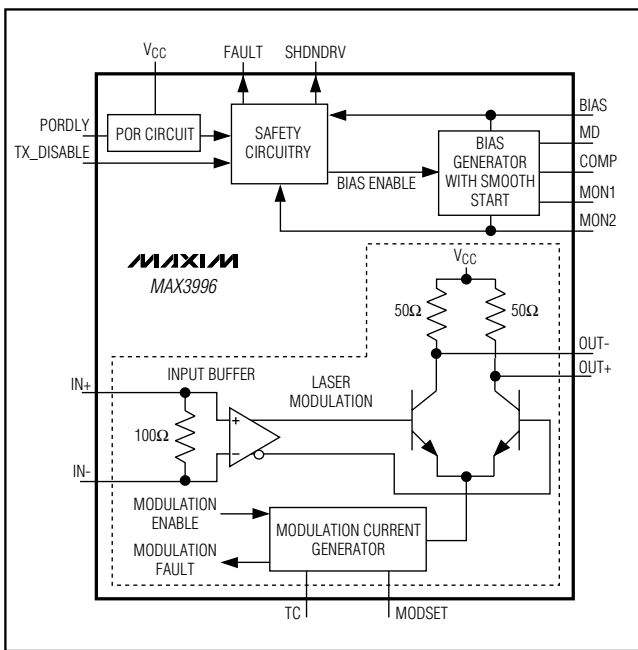

Figure 3. Laser Driver Functional Diagram

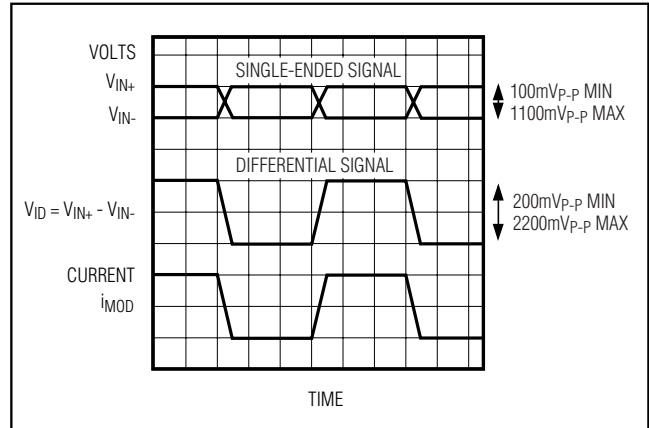

Figure 2. Required Input Signal and Modulation-Current Polarity

Bias Generator

Figure 4 shows the bias generator circuitry that contains a power-control amplifier, smooth-start circuitry, and two bias-fault sensors. The power-control amplifier combined with an internal NPN transistor provides DC laser current to bias the laser in a light-emitting state. The APC circuitry adjusts the laser bias current to maintain average power over temperature and changing laser properties. The smooth-start circuitry prevents current spikes to the laser during power-up or enable, ensuring compliance with safety requirements and extending the life of the laser.

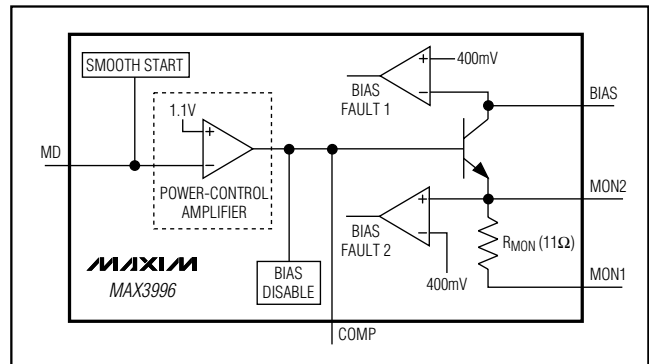

Figure 4. Bias Circuitry

The MD input is connected to the anode of a monitor diode, which is used to sense laser power. The BIAS output is connected to the cathode of the laser through an inductor or ferrite bead. The power-control amplifier drives a transistor to control the laser's bias current. In a fault condition (Table 1), the base of the bias-driving transistor is pulled low to ensure that bias current is turned off.

3.0V to 5.5V, 2.5Gbps VCSEL and Laser Driver

Table 1. Typical Fault Conditions

PIN	FAULT CONDITION
MON2	$V_{MON2} > 400mV$
BIAS	$V_{BIAS} < 400mV$
TC, MODSET	V_{MODSET} or $V_{TC} < 200mV$

Smooth-Start

During startup, the laser does not emit light, and the APC loop is not closed. The smooth-start circuit pulls the MD pin to approximately 2.5V during the POR delay and while TX_DISABLE is high. This causes the power-control amplifier to shut off the bias transistor. When POR delay is over and TX_DISABLE is low, the MD pin is released and pulled to GND by RSET because there is no laser power and thus no monitor diode current. The output voltage of the power-control amplifier then begins to increase. A capacitor attached to COMP (CCOMP) slows the slew rate and allows a controlled increase in bias current (Figure 11). Maxim recommends $C_{COMP} = 0.1\mu F$.

Modulation Circuitry

The modulation circuitry consists of an input buffer, a current mirror, and a high-speed current switch (Figure 5). The modulator drives up to 30mA of modulation current into a 25Ω load.

Many of the modulator performance specifications depend on total modulator current. To ensure good driver performance, the voltage at either OUT+ or OUT- must not be less than $V_{CC} - 1V$.

The amplitude of the modulation current is set with resistors at the MODSET and temperature coefficient (TC) pins. The resistor at MODSET (R_{MOD}) programs the temperature-stable portion of the modulation current, and the resistor at TC (R_{TC}) programs the temperature-increasing portion of the modulation current. Figure 6 shows modulation current as a function of temperature for two extremes: R_{TC} is open (the modulation current has zero temperature coefficient), and R_{MOD} is open (the modulation temperature coefficient is $4000ppm/^{\circ}C$). Intermediate temperature coefficient values of the modulation current can be obtained as described in the *Design Procedure* section. Table 2 is the R_{TC} and R_{MOD} selection table.

Safety Circuitry

The safety circuitry contains a disable input, a fault latch, and fault detectors (Figure 7). This circuitry monitors the operation of the laser driver and forces a shut-down if a single-point fault is detected. A single-point fault can be a short to V_{CC} or GND, or between any two

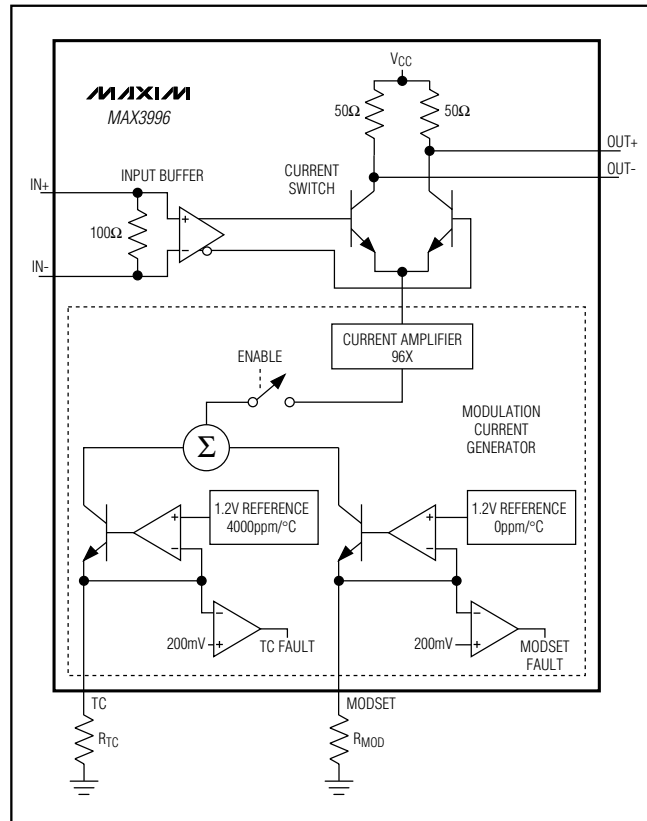

Figure 5. Modulation Circuitry

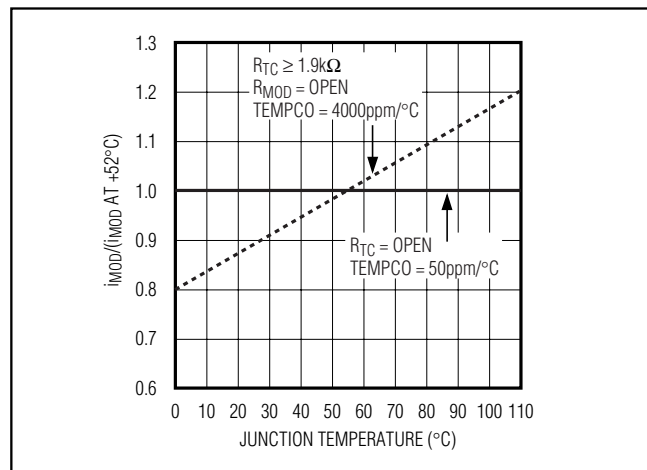

Figure 6. Modulation Current vs. Temperature for Maximum and Minimum Temperature Coefficient

3.0V to 5.5V, 2.5Gbps VCSEL and Laser Driver

MAX3996

Table 2. R_{TC} and R_{MOD} Selection Table

TEMPCO (ppm/°C)	i _{MOD} = 30mA		i _{MOD} = 15mA		i _{MOD} = 5mA	
	R _{MOD} (kΩ)	R _{TC} (kΩ)	R _{MOD} (kΩ)	R _{TC} (kΩ)	R _{MOD} (kΩ)	R _{TC} (kΩ)
3500	17.1	1.85	34.4	3.94	104	12.3
3000	8.04	2.19	16.3	4.64	49.5	14.4
2500	5.20	2.68	10.6	5.62	32.4	17.4
2000	3.81	3.42	7.86	7.08	24.1	21.8
1500	2.98	4.64	6.21	9.53	19.1	29.1
1000	2.44	7.08	5.12	14.4	15.9	43.8
500	2.05	14.4	4.34	29.1	13.5	87.8

Table 3. Circuit Responses to Various Single-Point Faults

PIN NAME	CIRCUIT RESPONSE TO OVERVOLTAGE OR SHORT TO V _{CC}	CIRCUIT RESPONSE TO UNDERVOLTAGE OR SHORT TO GROUND
TC	Does not affect laser power.	Fault state* occurs.
FAULT	Does not affect laser power.	Does not affect laser power.
TX_DISABLE	Modulation and bias current are disabled.	Normal condition for circuit operation.
PORDLY	Does not affect laser power.	Modulation and bias current are disabled.
IN+, IN-	Does not affect laser power.	Does not affect laser power.
MON1	Fault state* occurs.	Does not affect laser power.
MON2	Fault state* occurs.	Does not affect laser power.
COMP	A fault is detected at either the collector or the emitter of the internal bias transistor, and a fault state* occurs. If the shutdown circuitry is used, bias current is shut off.	Disables bias current.
MD	Disables bias current.	The APC circuit responds by increasing bias current until a fault is detected at the emitter or collector of the bias transistor, and then a fault* state occurs.
SHDNDRV	Does not affect laser power. If the shutdown circuitry is used, bias current is shut off.	Does not affect laser power.
BIAS	In this condition, laser forward voltage is 0V and no light is emitted.	Fault state* occurs. If the shutdown circuitry is used, bias current is shut off.
OUT+, OUT-	Does not affect laser power.	Does not affect laser power.
MODSET	Does not affect laser power. Fault* state may occur.	Fault state* occurs.

*A fault state asserts the FAULT pin, disables the modulator outputs, disables the bias output, and asserts the SHDNDRV pin.

IC pins. See Table 3 to view the circuit response to various single-point failures. The shutdown condition is latched until reset by a toggle of TX_DISABLE or V_{CC}.

Fault Detection

All critical nodes are monitored for safety faults, and any node voltage that differs significantly from its expected value results in a fault (Table 1). When a fault condition is detected, the laser is shut down. See the

Applications Information for more information on laser safety.

Shutdown

The laser driver offers redundant bias shutdown. The SHDNDRV output drives an optional external transistor. The bias and modulation drivers have separate internal disable signals.

3.0V to 5.5V, 2.5Gbps VCSEL and Laser Driver

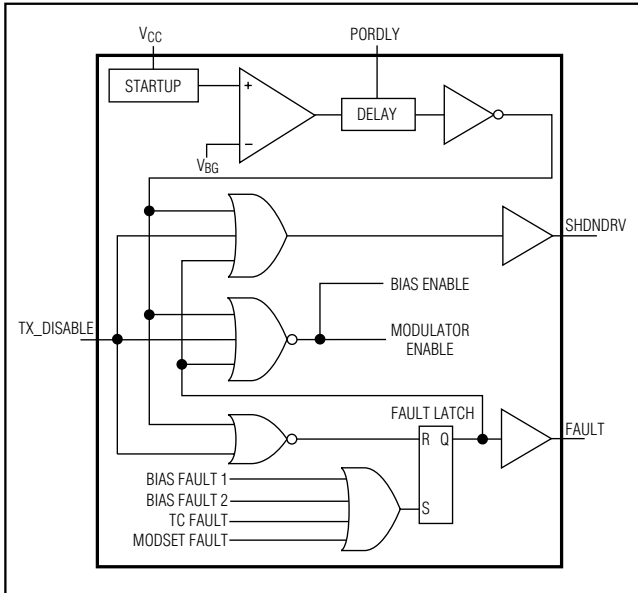

Figure 7. Safety Circuitry Functional Diagram

Latched Fault Output

An open-collector FAULT output is provided with the MAX3996. This output is latched until the power is switched off, then on, or until TX_DISABLE is switched to HIGH and then LOW.

Power-On Reset

The MAX3996 contains an internal power-on reset delay to reject noise on V_{CC} during power-on or hot-plugging. Adding capacitance to the PORDLY pin can extend the delay. The POR comparator includes hysteresis to improve noise rejection.

Design Procedure

Select Laser

Select a communications-grade laser with a rise time of 260ps or better for 1.25Gbps or 130ps or better for 2.5Gbps applications. To meet the MAX3996's AC specifications, the voltage at both OUT+ and OUT- must remain above V_{CC} - 1V at all times.

Use a high-efficiency laser that requires low modulation current and generates a low voltage swing. Trimming the leads can reduce laser package inductance. Typical package leads have inductance of 25nH per inch (1nH/mm); this inductance causes a large voltage swing across the laser. A compensation filter network also can be used to reduce ringing, edge speed, and voltage swing.

Programming Modulation Current

Resistors at the MODSET and TC pins set the amplitude of the modulation current. The resistor R_{MOD} sets the temperature-stable portion of the modulation current, and the resistor (R_{TC}) sets the temperature-increasing portion of the modulation current. To determine the appropriate temperature coefficient from the slope efficiency (η) of the laser, use the following equation:

$$\text{LASER_TEMPCO} = \frac{\eta_{70} - \eta_{25}}{\eta_{25}(70^{\circ}\text{C} - 25^{\circ}\text{C})} \times 10^6$$

[ppm/°C]

For example, if a laser has a slope efficiency $\eta_{25} = 0.021\text{mW/mA}$, which reduces to $\eta_{70} = 0.018\text{mW/mA}$. Using the above equation will produce a laser tempco of $-3175\text{ppm/}^{\circ}\text{C}$.

To obtain the desired modulation current and tempco for the device, the following equations can be used to determine the required values of R_{MOD} and R_{TC}:

$$R_{TC} = \frac{0.22}{\text{Tempco}/10^6 \times i_{MOD}} - 250\Omega$$

$$R_{MOD} = \frac{\text{Tempco}/10^6 (R_{TC} + 250\Omega) 52}{(0.19 - 48 \times \text{Tempco}/10^6)} - 250\Omega$$

where tempco = -laser tempco, $0 < \text{tempco} < 4000\text{ppm/}^{\circ}\text{C}$, and $2\text{mA} < i_{MOD} < 30\text{mA}$.

Figure 8 shows a family of curves derived from these equations. The straight diagonal lines depict constant tempcos. The curved lines represent constant modulation currents. If no temperature compensation is desired, leave TC open, and the equation for i_{MOD} simplifies considerably.

The following equations were used to derive Figure 8 and the equations at the beginning of this section.

$$i_{MOD} = 77 \times \frac{50}{50 + R_L} \left[\frac{1.15}{R_{MOD} + 250\Omega} + \frac{1.06}{R_{TC} + 250\Omega} (1 + 0.004(T - 25^{\circ}\text{C})) \right] \text{Amps}$$

3.0V to 5.5V, 2.5Gbps VCSEL and Laser Driver

MAX3996

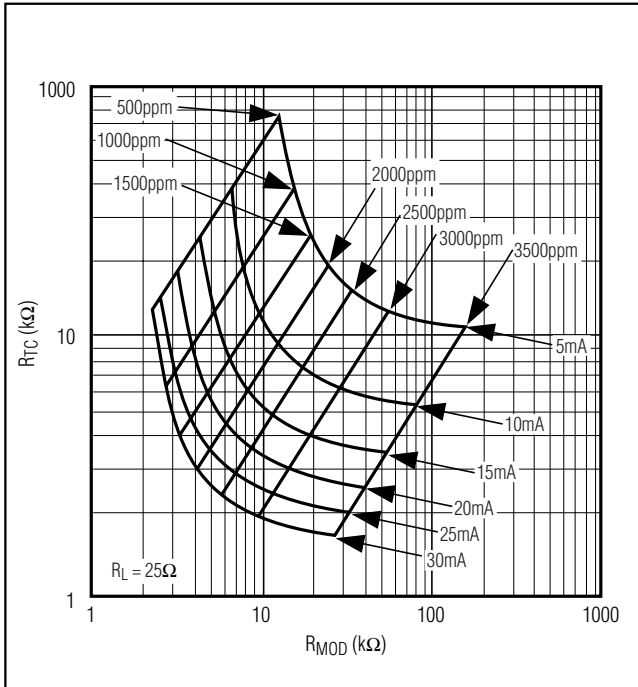

Figure 8. R_{TC} vs. R_{MOD} for Various Conditions

Determine Modulator Configuration

The MAX3996 can be used in several configurations. For modulation currents less than 20mA, Maxim recommends the configuration shown in the *Typical Application Circuit*. Outputs greater than 20mA could cause the voltage at the modulator output to be less than $V_{CC} - 1V$, which might degrade laser output. For large currents, Maxim recommends the configuration in Figure 9. A differential configuration is in Figure 10.

Designing the Bias Filter and Output Pullup Beads

To reduce deterministic jitter, add a ferrite bead inductor ($L1$) between the BIAS pin and the cathode of the laser. Select $L1$ to have an impedance $>100\Omega$ between $f = 10MHz$ and $f = 2GHz$, and a DC resistance $< 3\Omega$; Maxim recommends the Murata BLM11HA102SG. These inductors are also desirable for connecting the OUT+ and OUT- pins to V_{CC} .

Programming Laser Power and Bias Fault Threshold

The IC is designed to drive a common anode laser with a photodiode. A servo-control loop is formed by the internal NPN bias-driving transistor, the laser diode, the monitor diode (R_{SET}), and the power-control amplifier (Figure 11). The voltage at MD is stabilized to 1.1V. The

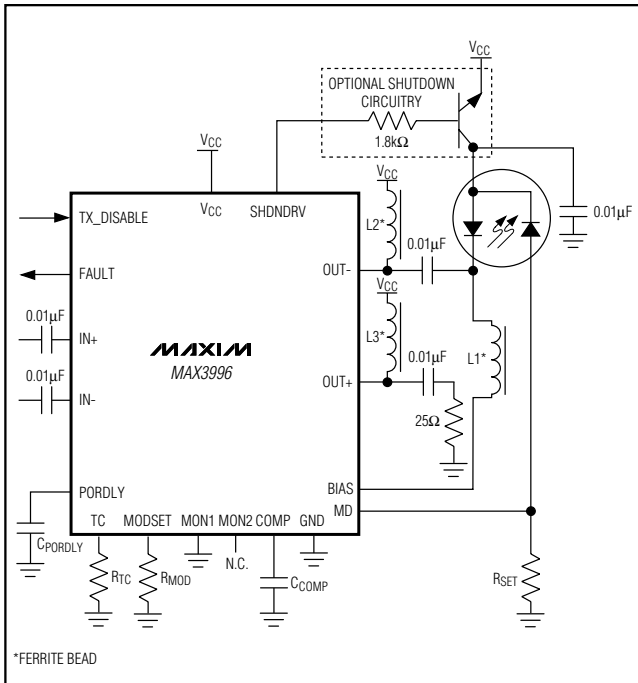

Figure 9. Large Modulation Current

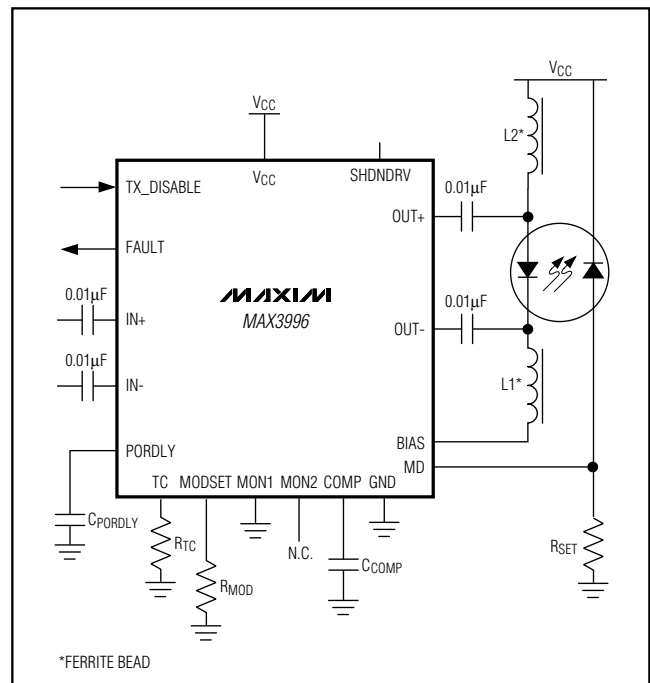

Figure 10. Differential Configuration

3.0V to 5.5V, 2.5Gbps VCSEL and Laser Driver

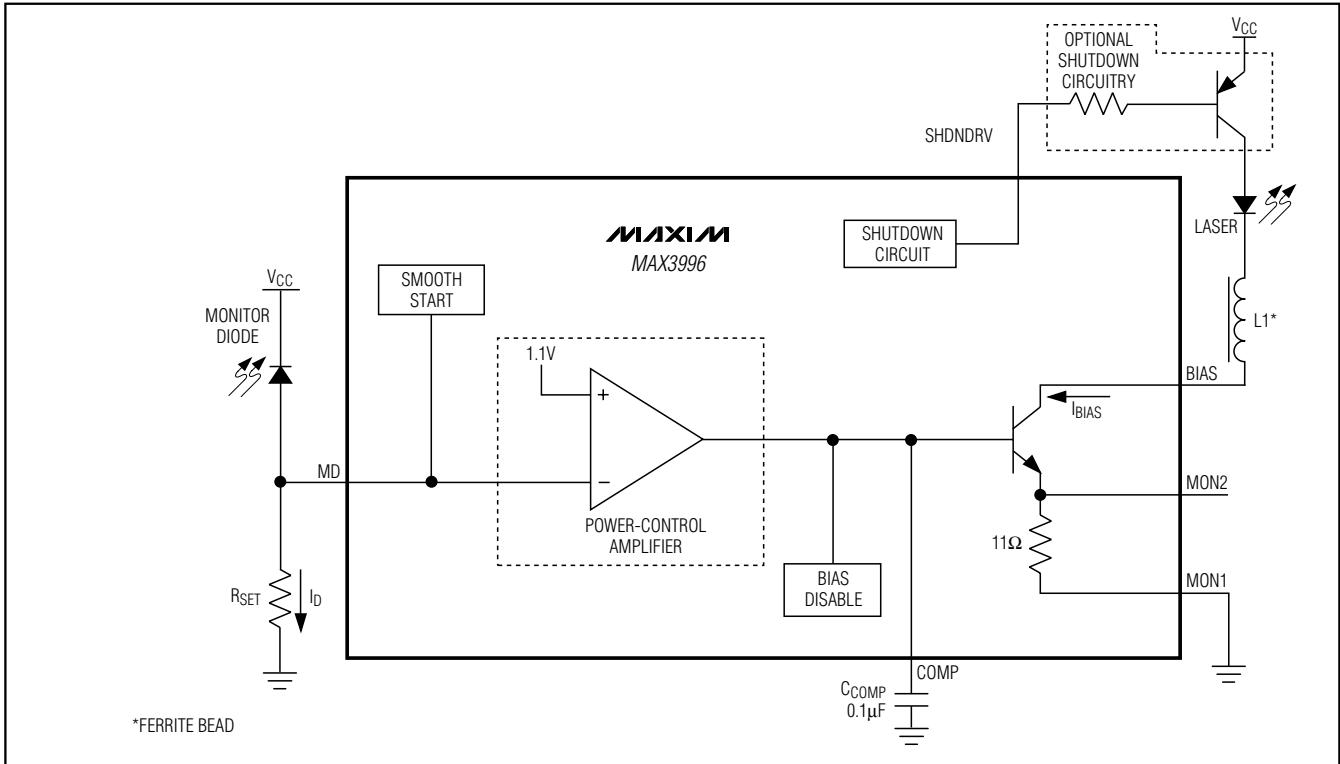

Figure 11. APC Loop

monitor photodiode current is set by $I_D = V_{MD}/R_{SET}$. Determine the desired monitor current (I_D), and then select $R_{SET} = 1.1V/I_D$.

A bias stabilizing capacitor (C_{COMP}) must be connected between the COMP pin and ground to obtain the desired APC loop time constant. This improves power-supply and ground noise rejection. A capacitance of 0.1μF usually is sufficient to obtain time constants of up to 35μs.

The degeneration resistance between MON2 and ground determines the bias current that causes a fault and affects the APC time constant. Select R_{MON} (the total resistance between MON2 and ground) = 400mV/(maximum bias current). A degeneration resistance of 10Ω can be obtained by grounding MON1. Increasing R_{MON} increases the APC time constant.

The discrete components for use with the common anode with photodiode configuration are:

$$R_{SET} = 1.1V/I_D$$

$$C_{COMP} = 0.1\mu F \text{ (typ)}$$

$$L1 = \text{ferrite bead, see the Bias Filter section}$$

$$R_{MON} = 400mV/(\text{maximum bias current})$$

Programming POR Delay

A capacitor can be added to PORDLY to increase the delay when powering up the part. The delay will be approximately:

$$t = \frac{C_{PORDLY}}{1.4 \times 10^{-6}} \text{ seconds}$$

See the *Typical Operating Characteristics* section.

Designing the Laser-Compensation Filter Network

Laser package inductance causes the laser impedance to increase at high frequencies, leading to ringing, overshoot, and degradation of the laser output. A laser-compensation filter network can be used to reduce the laser impedance at high frequencies, thereby reducing output ringing and overshoot.

3.0V to 5.5V, 2.5Gbps VCSEL and Laser Driver

The compensation components (R_F and C_F) are most easily determined by experimentation. For interfacing with edge-emitting lasers, refer to application note HFAN-2.0, *Interfacing Maxim Laser Drivers with Laser Diodes*. Begin with $R_F = 50\Omega$ and $C_F = 2\text{pF}$. Increase C_F until the desired transmitter response is obtained (Figure 12).

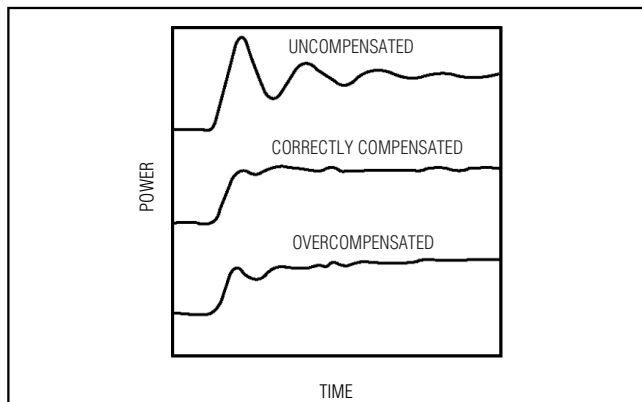

Figure 12. Laser Compensation

Using External Shutdown

To achieve single-point fault tolerance, Maxim recommends an external shutdown transistor (Figure 11). In the event of a fault, SHDNDRV asserts high, placing the shutdown transistor in cutoff mode and thereby shutting off the bias current.

Applications Information

Laser Safety and IEC825

The International Electrotechnical Commission (IEC) determines standards for hazardous light emissions from fiber optic transmitters. IEC 825 defines the maximum light output for various hazard levels. The MAX3996 provides features that facilitate compliance with IEC825. A common safety precaution is single-point fault tolerance, whereby one unplanned short, open, or resistive connection does not cause excess light output. When this laser driver is used, as shown in the *Typical Application Circuit*, the circuits respond to faults as listed in Table 3. Using this laser driver alone does not ensure that a transmitter design is compliant with IEC825. The entire transmitter circuit and component selections must be considered. Customers must determine the level of fault tolerance required by their applications, recognizing that Maxim products are not designed or authorized for use as components in systems intended for surgical implant into the body, for applications intended to support or sustain life, or for any other application where the failure of a Maxim

product could create a situation where personal injury or death may occur.

Layout Considerations

The MAX3996 is a high-frequency product whose performance largely depends upon the circuit board layout. Use a multilayer circuit board with a dedicated ground plane. Use short laser-package leads placed close to the modulator outputs. Power supplies must be capacitively bypassed to the ground plane, with surface-mount capacitors placed near the power-supply pins.

The dominant pole of the APC circuit normally is at COMP. To prevent a second pole in the APC that can lead to oscillations, ensure that parasitic capacitance at MD is minimized (10pF).

Common Questions

Laser output is ringing or contains overshoot. Inductive laser packaging often causes this. Try reducing the length of the laser leads. Modify the filter components to reduce the driver's output edge speed (see the *Design Procedure* section). Extreme ringing can be caused by low voltage at the $\text{OUT}\pm$ pins. This might indicate that pullup beads or a lower modulation current are needed.

Low-frequency oscillation on the laser output. This is more prevalent at low temperatures. The APC might be oscillating. Try increasing the value of C_{COMP} or add additional degeneration by placing some resistance from MON1 to GND. Ensure that the parasitic capacitance at the MD node is kept very small ($<10\text{pF}$).

The APC is not needed. Connect BIAS to V_{CC} , leave MD open, and connect MON2 and COMP to ground.

The modulator is not needed. Leave TC and MODSET open. Connect $\text{IN}+$ to V_{CC} , $\text{IN}-$ to ground through 750Ω , and leave $\text{OUT}+$ and $\text{OUT}-$ open.

Interface Models

Figures 13–17 show typical models for the inputs and outputs of the MAX3996, including package parasitics.

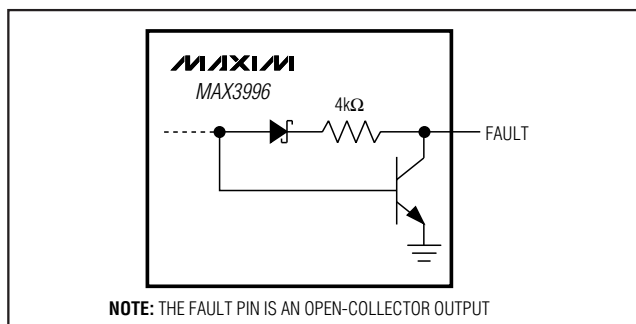

Figure 13. FAULT Output

3.0V to 5.5V, 2.5Gbps VCSEL and Laser Driver

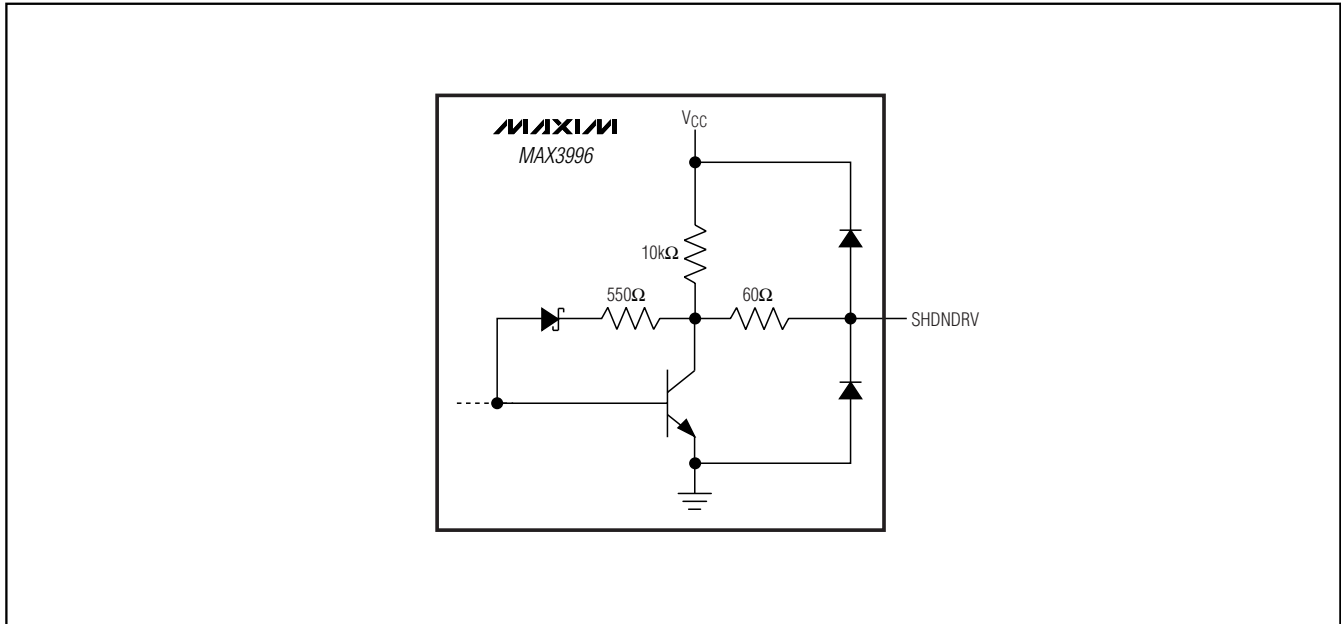

Figure 14. SHDNDRV Output

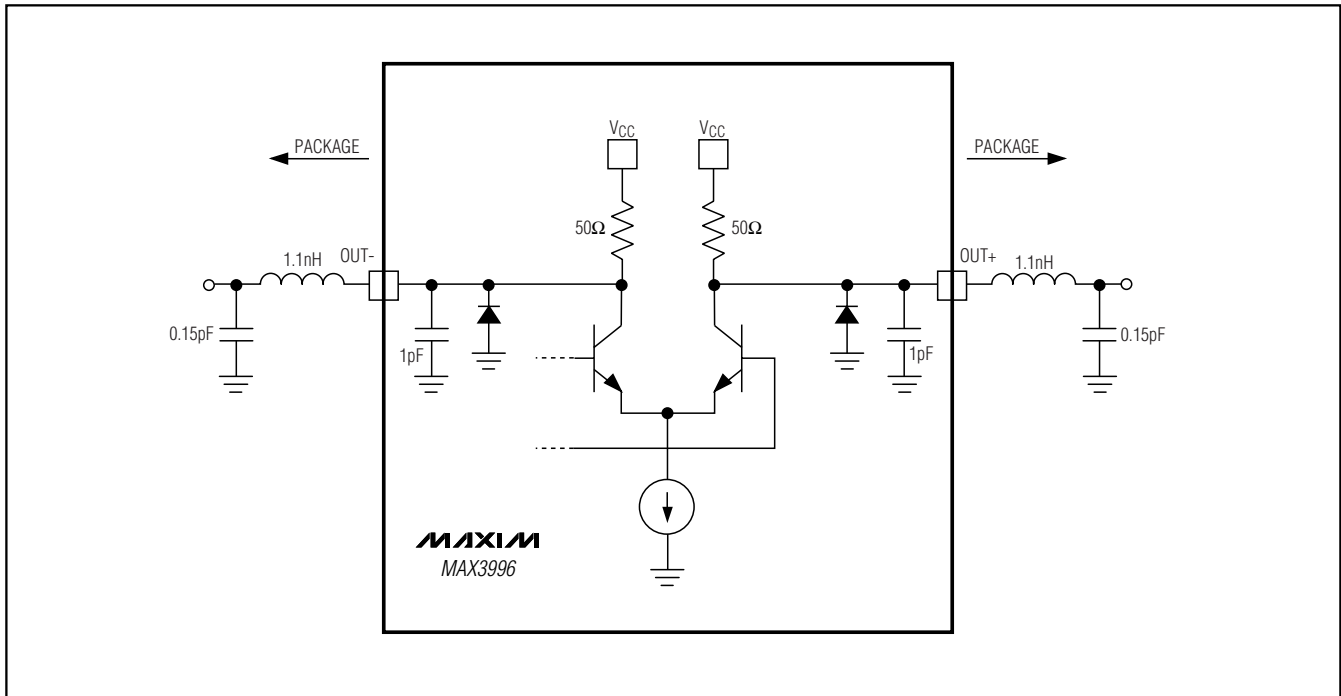

Figure 15. Modulator Outputs

3.0V to 5.5V, 2.5Gbps VCSEL and Laser Driver

MAX3996

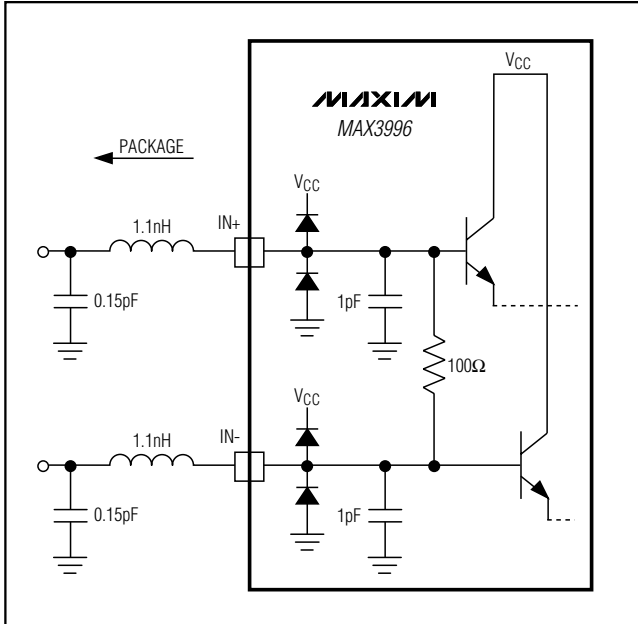

Figure 16. Data Inputs

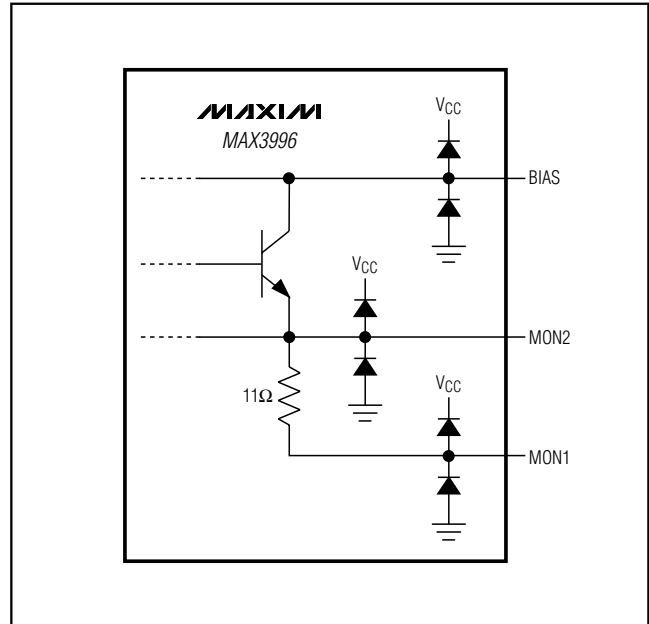
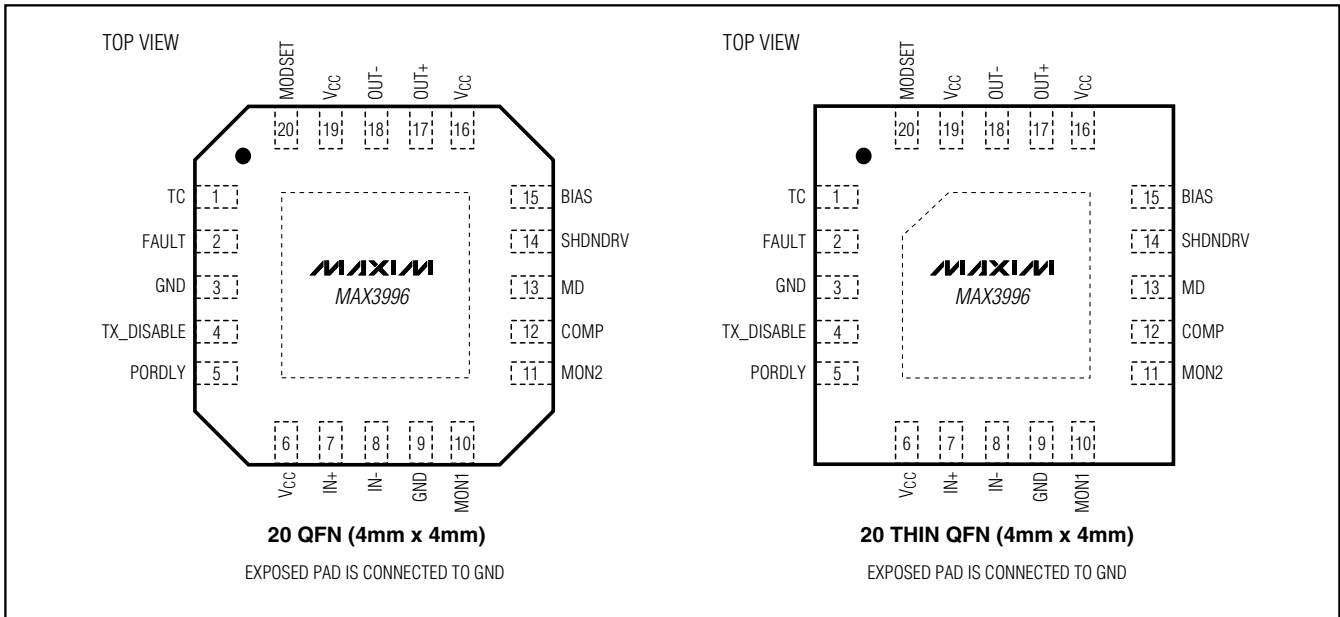

Figure 17. BIAS Output

Pin Configurations



Chip Information

TRANSISTOR COUNT: 1061
PROCESS: SILICON BIPOLAR

3.0V to 5.5V, 2.5Gbps VCSEL and Laser Driver

Package Information

For the latest package outline information, go to
www.maxim-ic.com/packages.

PART	PACKAGE TYPE	PACKAGE CODE
MAX3996CGP	20 QFN 4mm x 4mm x 0.9mm	G2044-3
MAX3996CTP+	20 Thin QFN 4mm x 4mm x 0.8mm	T2044-3

Maxim cannot assume responsibility for use of any circuitry other than circuitry entirely embodied in a Maxim product. No circuit patent licenses are implied. Maxim reserves the right to change the circuitry and specifications without notice at any time.

16 **Maxim Integrated Products, 120 San Gabriel Drive, Sunnyvale, CA 94086 408-737-7600**