

8 7 6 5 4 3 2 1

- NOTES:**
- MOUNTING:** Mounts in a $\phi .171 \pm .002$ [$\phi 4.34\text{mm} \pm .05$] panel hole on .250 [6.35mm] centers. Panel thickness .031 [.8mm] to .062 [1.59mm]. Panel hole should be deburred, but not chamfered.
 - ASSEMBLY:** Insert lens through panel hole, and insert LED into lens.
 - MATERIAL:** Polycarbonate, UL 94-V2
GLO Series- Polycarbonate & Acrylic blend
 - U.S. & Foreign Pat. Issued & Pend.**

REVISIONS				
ECN#	REV.	DESCRIPTION	DATE	INITIALS
	1	ADD GLO SERIES	1-6-10	JG
	001	REVISED PER ECR111009AZ01	4-23-10	SMU

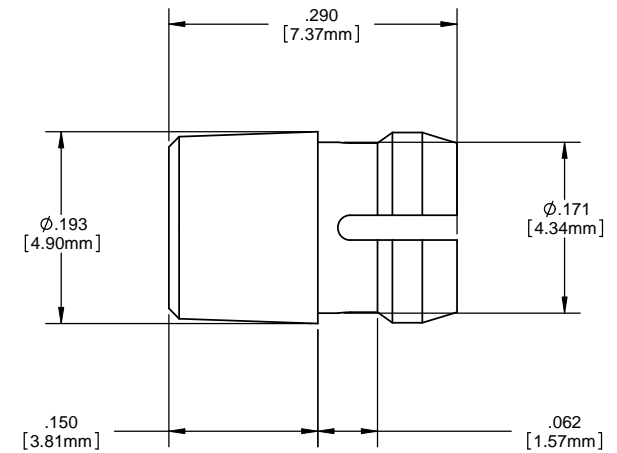
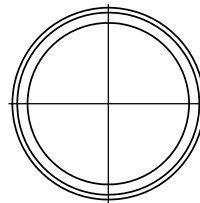
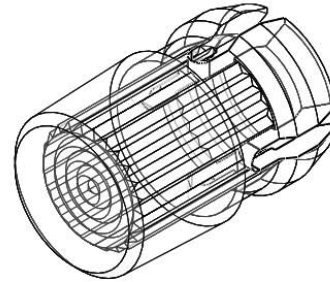

ORDERING CODE : **SML 190 XXX**

MODEL

LENS COLOR	
RTP	RED TRANSPARENT
ATP	AMBER TRANSPARENT
GTP	GREEN TRANSPARENT
BTP	BLUE TRANSPARENT
YTP	YELLOW TRANSPARENT
CTP	CLEAR TRANSPARENT
GLO	WHITE TRANSLUCENT

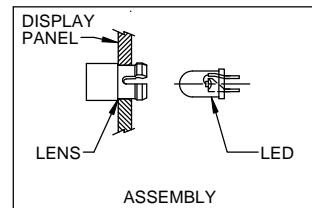

<small>UNLESS OTHERWISE SPECIFIED DIMENSIONS ARE IN INCHES</small> ANGLES DECIMALS $\pm 1^\circ$.X $\pm .020$.XXX $\pm .010$ FINISH .XXX $\pm .005$ BREAK ALL CORNERS AND SHARP EDGES (R1/16") THIRD ANGLE PROJECTION <small>THE INFORMATION CONTAINED IN THIS DRAWING IS THE SOLE PROPERTY OF VISUAL COMMUNICATIONS COMPANY, INC. AND IS LOANED TO YOU AS A SINGLE COPY. IT IS NOT TO BE REPRODUCED OR TRANSMITTED IN ANY FORM OR BY ANY MEANS, ELECTRONIC OR MECHANICAL, INCLUDING PHOTOCOPYING, RECORDING, OR BY ANY INFORMATION STORAGE AND RETRIEVAL SYSTEM, WITHOUT THE WRITTEN CONSENT OF VISUAL COMMUNICATIONS COMPANY, INC.</small>	MATERIAL POLYCARBONATE, UL 94-V2	VISUAL COMMUNICATIONS COMPANY, INC. 190 Bosstick Boulevard, Suite 101 San Marcos, CA 92069 USA Phone (760) 560-1300 Fax (760) 560-1301 email vccsales@vccite.com
	FINISH SEE NOTES	TITLE: 3MM ROUND STANDARD HEIGHT FRESNEL LENS
<small>APPROVAL</small> DRAWN: SMU 4-23-10 CHECKED: DZ 4-23-10 DO NOT SCALE DRAWING	<small>DATE</small> DATE: 4-23-10	<small>SIZE</small> B
<small>DWG. NO.</small> SML 190 XXX		<small>REV</small> 001
<small>SCALE: 12:1</small>		<small>SHEET 1 OF 1</small>

8 7 6 5 4 3 2 1