

F2 Series Double Pedal Foot Switches

F2 UN

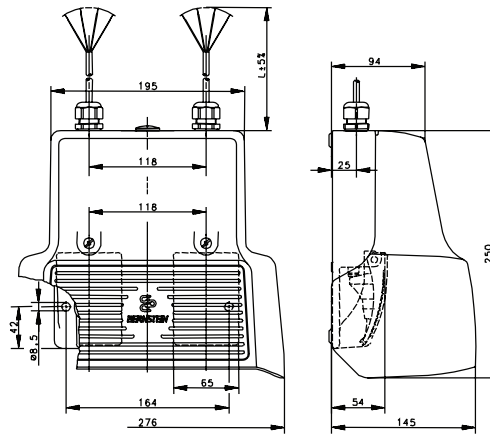

F2

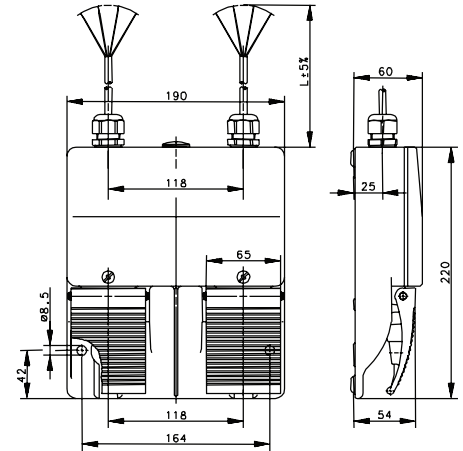

6.5' (2 meter) connection cable

-
-

609.6198.022
F2-SU1Z/SU1Z EX -2M-

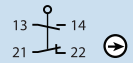

16.4' (5 meter) connection cable

609.6197.029
F2-SU1Z/SU1Z EX UN -5M-



-
-

29.5' (9 meter) connection cable

-
-

-
-

EX Certification

II 2 G EEx d IIC T6

II 2 G EEx d IIC T6

Technical Information

Maximum Switching Voltage	230V	230V
Maximum Switching Amperage	5A	5A
B10d	4 Million	4 Million
Mechanical Service Life	2 x 10 ⁶	2 x 10 ⁶
Switching Frequency	≤ 50/min	≤ 50/min
Operating Temperature	-20 °C to +65 °C	-20 °C to +65 °C
Protection Rating	IP66 / IP67	IP66 / IP67
Utilization Category	AC 15, 240 V / 3 A; DC 13, 250 V / 0.27 A	AC 15, 240 V / 3 A; DC 13, 250 V / 0.27 A
Rate Insulation Voltage	250VAC	250VAC

Drawing dimensions in mm