

Push Button Reboot Controller

■ GENERAL DESCRIPTION

The XC6190 series are timer reset ICs that supply a reboot signal to the system when “L” voltage is input into the SW1, SW2 pins for a set time (reboot delay time) using two switches (physical buttons).

On type A, the reboot delay time (T_{DL}) can be set as desired by changing the external resistance R_T within the range 1s to 20s. On type B, T_{DL} is fixed internally. When the TS pin is set to “H” level, the delay time is 12.5s. When the TS pin is set to “L” level, the delay time is 7.5s.

After the reboot signal (T_{RSTB}) is output for 0.4s (TYP), the IC automatically returns to the steady state.

Quiescent current in standby mode is a very small $0.01\mu\text{A}$ (TYP.), and this contributes to a longer battery drive time. The small USPN-6 and USPN-6B01 packages enable reduction of mounting space.

The UVLO function is equipped as a protective function to prevent malfunctioning of the IC.

■ APPLICATIONS

- Wearable Devices
- Portable Music Players
- Portable Video Game Players
- Wireless Headsets
- Mobile Communication Devices
- Smart Phones, Feature Phones
- Various applications equipped with buttons

■ FEATURES

Input Voltage Range	: 1.75V ~ 6.0V
Low power Consumption	: $0.01\mu\text{A}$ (Stand-by, TYP.)
Output Configuration	: Nch open drain (XC6190AN/BN) CMOS output (XC6190AC/BC)
RSTB Pin SINK Current	: 30mA ($V_{RSTBL}=0.3\text{V}$.)
Reboot Delay Time (Type A)	: 1s ~ 20s (Adjustable by the external resistor) * $12.5\text{s} \pm 5\%$ ($R_T=200\text{k}\Omega$)
Reboot Delay Time (Type B)	: $7.5\text{s} \pm 5\%$ (TS=GND) $12.5\text{s} \pm 5\%$ (TS= V_{IN})
Reboot Time	: $0.4\text{s} \pm 5\%$
Operating Ambient Temperature	: $-40^\circ\text{C} \sim +85^\circ\text{C}$
Package	: USPN-6, USPN-6B01
Environmentally Friendly	: RoHS Compliant, Pb Free

■ TYPICAL APPLICATION CIRCUIT

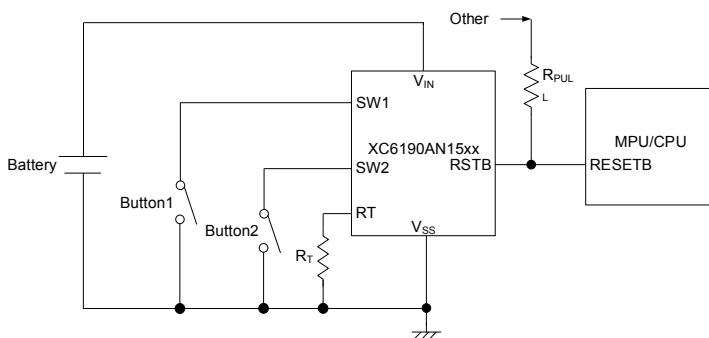

A type: Two-Button Solution

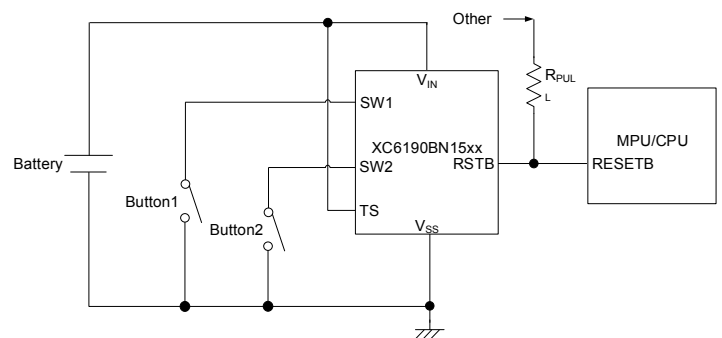

B type: Two-Button Solution

*1) On the XC6190AN15xx, XC6190BN25xx, connect a capacitor of at least $0.01\mu\text{F}$ between V_{IN} -GND near the IC as needed.

*2) On the XC6190AC15xx, XC6190BC25xx, connect a capacitor of at least $0.01\mu\text{F}$ between V_{IN} -GND near the IC.

(Note) The following products are under development.

XC6190AC158R-G

■ BLOCK DIAGRAM

1) XC6190AN15xx

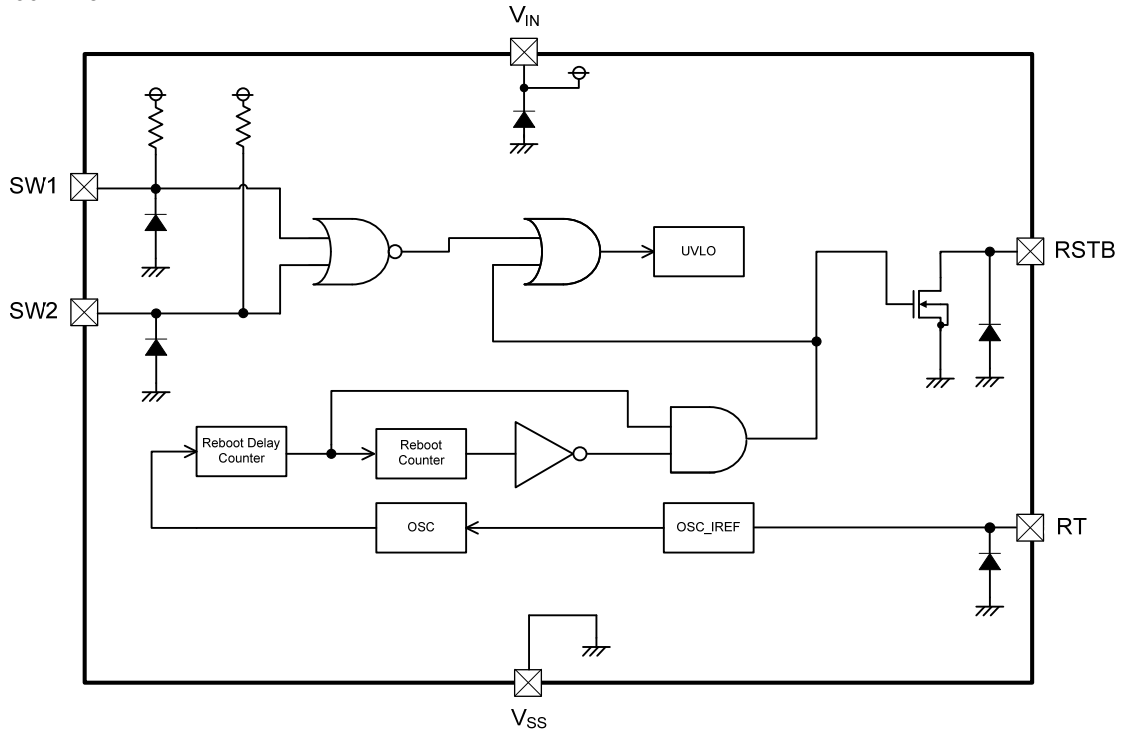

* The above diodes are electrostatic protection diodes and parasitic diodes.

2) XC6190AC15xx

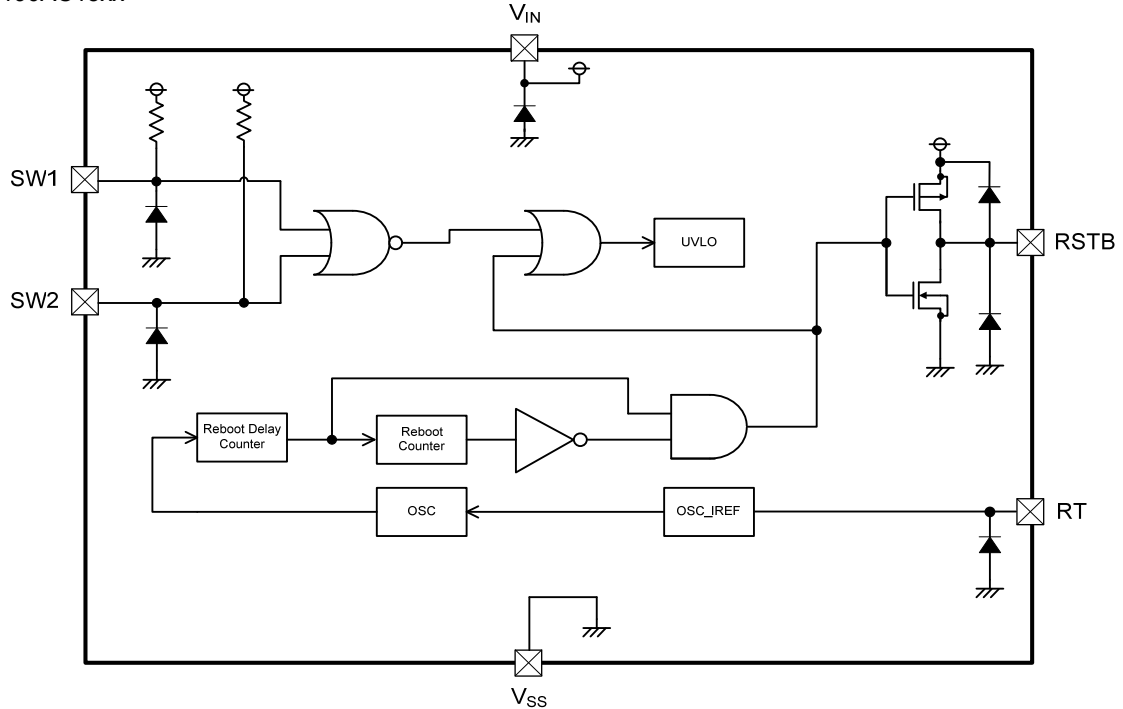

* The above diodes are electrostatic protection diodes and parasitic diodes.

(Note) The following products are under development.

XC6190AC158R-G

■ BLOCK DIAGRAM

3) XC6190BN25xx

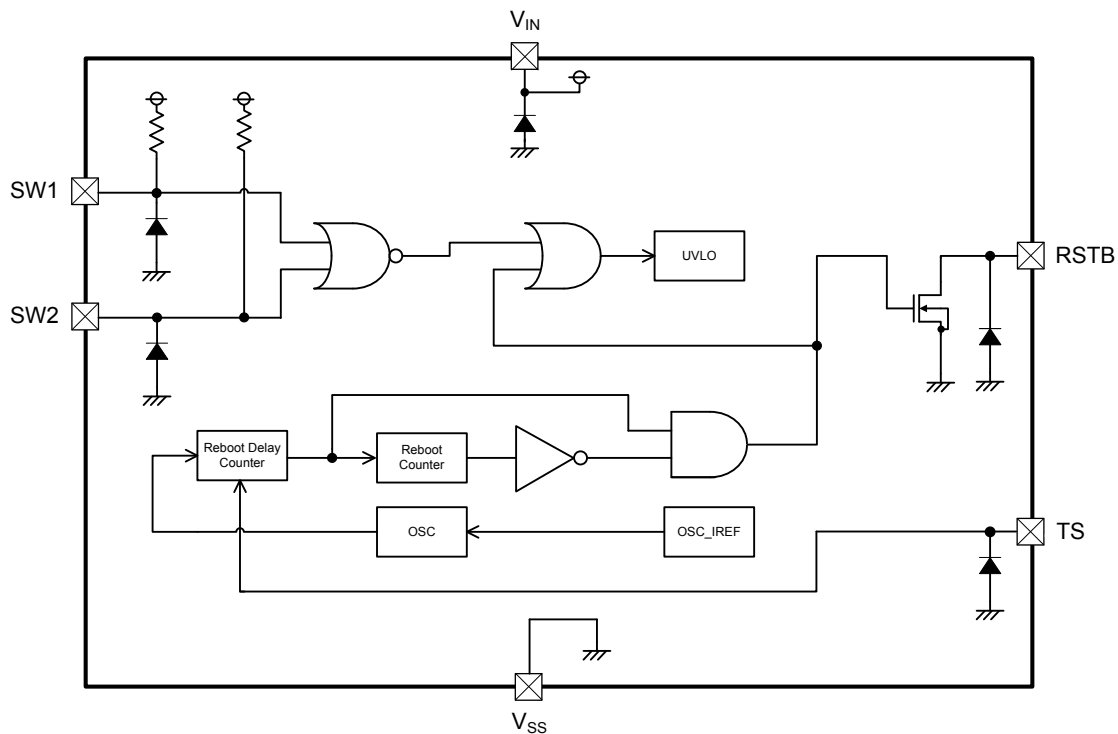

* The above diodes are electrostatic protection diodes and parasitic diodes.

4) XC6190BC25xx

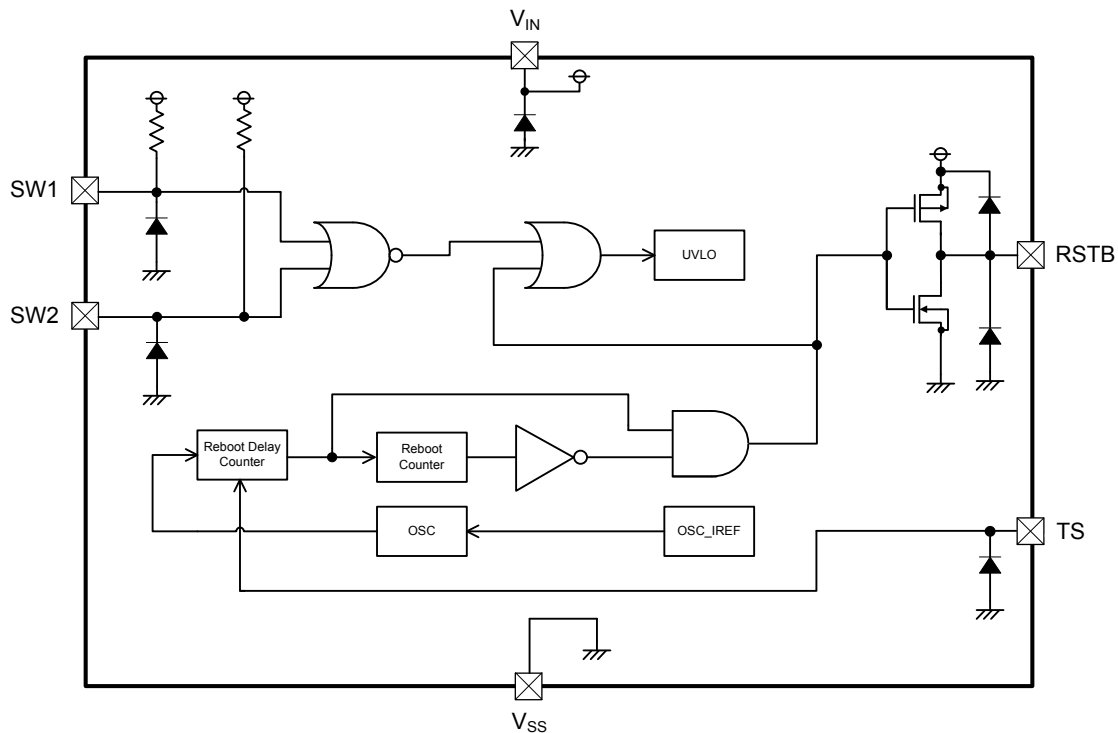

* The above diodes are electrostatic protection diodes and parasitic diodes.

(Note) The following products are under development.

XC6190AC158R-G

■ PRODUCT CLASSIFICATION

● Ordering Information

XC6190①②③④⑤⑥-⑦^(*)

DESIGNATOR	ITEM	SYMBOL	DESCRIPTION
①	TYPE	A	Reboot delay time set by the External RT.
		B	Reboot delay time internal fix.
②	Output Configuration	N	N-ch open drain output
		C	CMOS output
③	Reboot delay time	1	Type A : 12.5s (External RT=200kΩ)
		2	Type B : 7.5s($V_{TS}=L$), 12.5s($V_{TS}=H$)
④	Reboot delay time accuracy	5	±5%
⑤⑥-⑦	Packages (Order Unit)	7R-G	USPN-6 (5,000 / Reel)
		8R-G	USPN-6B01 (5,000 / Reel)

^(*) The "-G" suffix denotes Halogen and Antimony free as well as being fully EU RoHS compliant.

(Note) The following products are under development.

XC6190AC158R-G

■ PIN CONFIGURATION

XC6190AN15xx / XC6190AC15xx

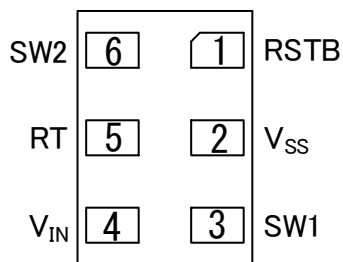

USPN-6B01
(BOTTOM VIEW)

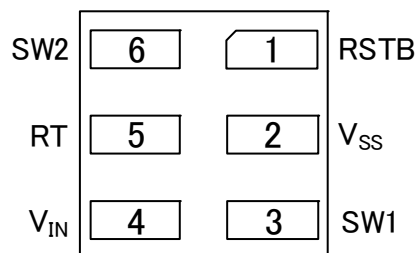

USPN-6
(BOTTOM VIEW)

XC6190BN25xx / XC6190BC25xx

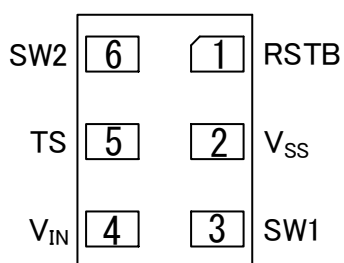

USPN-6B01
(BOTTOM VIEW)

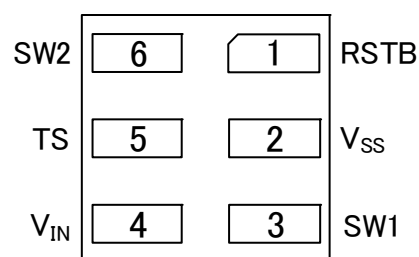

USPN-6
(BOTTOM VIEW)

■ PIN ASSIGNMENT

PIN NUMBER		PIN NAME	FUNCTIONS
USPN-6B01	USPN-6		
1	1	RSTB	Reboot Signal Output Pin
2	2	V _{SS}	Ground Pin
3	3	SW1	Switch Signal(1) Input Pin
4	4	V _{IN}	Power Input Pin
5	5	RT	Type A : T _{DL} adjusting resistor connection Pin
		TS	Type B : T _{DL} selection Pin
6	6	SW2	Switch Signal(2) Input Pin

(Note) The following products are under development.

XC6190AC158R-G

FUNCTION TABLE

PIN	BIAS CONDITION	STATUS
SW1	H	Standby Mode
	L	Active Mode
	OPEN	Standby Mode
SW2	H	Standby Mode
	L	Active Mode
	OPEN	Standby Mode
TS ^(*)	H ^(*)	T _{DL} =12.5s
	L ^(*)	T _{DL} =7.5s
	OPEN	Undefined State ^(*)

^(*) When either the SW1 pin or the SW2 pin is H-level, the IC enters Standby Mode.

^(*) Short-circuited the TS pin to V_{IN} or GND.

^(*) Leaving the TS pin open is prohibited as it will cause unstable operation.

^(*) TS pin "H" level is V_{IN} level.

^(*) TS pin "L" level is GND level.

ABSOLUTE MAXIMUM RATINGS

Ta=25°C

PARAMETER	SYMBOL	RATINGS	UNITS
VIN Pin Voltage	V _{IN}	-0.3 ~ +7.0	V
SW1 Pin Voltage	V _{SW1}	-0.3 ~ +7.0	V
SW2 Pin Voltage	V _{SW2}	-0.3 ~ +7.0	V
RT Pin Voltage	V _{RT}	-0.3 ~ V _{IN} +0.3 or +7.0 ^(*) ^(*)	V
TS pin Voltage	V _{TS}	-0.3 ~ V _{IN} +0.3 or +7.0 ^(*) ^(*)	V
RSTB Pin Voltage	V _{RSTB}	-0.3 ~ +7.0 ^(*)	V
		-0.3 ~ V _{IN} +0.3 or +7.0 ^(*) ^(*)	
RSTB Pin SINK Current	I _{SINK}	40	mA
RSTB Pin SOURCE Current	I _{SOURCE}	40 ^(*)	mA
Power Dissipation	USPN-6	Pd	mW
	USPN-6B01		
Operating Ambient Temperature	T _{opr}	-40 ~ +85	°C
Storage Temperature	T _{stg}	-55 ~ +125	°C

Each voltage rating is based on the reference V_{SS}.

^(*) The maximum value is the lower of either V_{IN} + 0.3 or +7.0V.

^(*) Apply to Type A.

^(*) Apply to Type B.

^(*) Apply to XC6190AN15xx and XC6190BN25xx.

^(*) Apply to XC6190AC15xx and XC6190BC25xx.

(Note) The following products are under development.

XC6190AC158R-G

■ ELECTRICAL CHARACTERISTICS

XC6190 AN15xx / XC6190AC15xx

Ta=25°C

PARAMETER	SYMBOL	CONDITIONS	MIN	TYP	MAX	UNIT	CIRCUIT
Input Voltage Range	V _{IN}	-	1.75	-	6.00	V	①
UVLO Release Voltage	V _{UVLOR}	V _{IN} =SWEEP (step up), V _{SW1} =GND, V _{SW2} =GND	-	1.55	1.65	V	①
UVLO Detect Voltage ^(*)	V _{UVLO}	V _{IN} =SWEEP (step down), V _{SW1} =GND, V _{SW2} =GND	1.35	1.47	-	V	①
Quiescent Current	I _Q	V _{IN} =6.0V,	-	0.01	0.10	μA	①
Operating Current ^(*)	I _{DD}	V _{IN} =6.0V, V _{SW1} =GND, V _{SW2} =GND	17	50	93	μA	①
Reboot Delay Time ^(*)	T _{DL}	V _{SW1} =GND, V _{SW2} =GND	11.875	12.500	13.125	s	②
Reboot Time ^(*)	T _{RSTB}	V _{SW1} =GND, V _{SW2} =GND *After T _{DL}	0.38	0.40	0.42	s	②
RSTB Pin SINK Current	I _{SINK}	V _{RSTB} =0.3V	30	-	-	mA	①
RSTB Pin SOURCE Current	I _{SOURCE}	XC6190AC15xx V _{RSTB} =V _{IN} -0.3V	20	-	-	mA	①
SW1 Pin "H" Voltage	V _{SW1H}	V _{IN} =6.0V	1.0	-	6.0	V	①
SW1 Pin "L" Voltage	V _{SW1L}	V _{IN} =6.0V	GND	-	0.3	V	①
SW1 Pin "H" Current	I _{SW1H}	V _{IN} =6.0V, V _{SW1} =6.0V	-0.1	-	0.1	μA	①
SW1 Pin "L" Current	I _{SW1L}	V _{IN} =6.0V, V _{SW1} =GND	3.5	7.5	16.0	μA	①
SW2 Pin "H" Voltage	V _{SW2H}	V _{IN} =6.0V	1.0	-	6.0	V	①
SW2 Pin "L" Voltage	V _{SW2L}	V _{IN} =6.0V	GND	-	0.3	V	①
SW2 Pin "H" Current	I _{SW2H}	V _{IN} =6.0V, V _{SW2} =6.0V	-0.1	-	0.1	μA	①
SW2 Pin "L" Current	I _{SW2L}	V _{IN} =6.0V, V _{SW2} =GND	3.5	7.5	16.0	μA	①

Unless otherwise stated, the reference is GND, V_{IN}=3.7V, RT=200kΩ SW1=open, SW2=open

(*) The UVLO detect voltage is less than the UVLO release voltage.

(*) Quiescent current until the reboot signal is output in the circuit operation state with the SW1, SW2 pin at "L" level

(*) Time from change of both SW1 and SW2 pin voltages to "L" level until the RSTB pin outputs "L" level^(*).

(*) Time from change of RSTB pin to "L" level until RSTB pin changes to "H" level^(*).

(*) RSTB pin "L" level is as follows: AN type: Applied voltage × 0.1 , AC type: V_{IN} × 0.1

(*) RSTB pin "H" level is as follows: AN type: Applied voltage × 0.9 , AC type: V_{IN} × 0.9

(Note) The following products are under development.

XC6190AC158R-G

ELECTRICAL CHARACTERISTICS (Continued)

XC6190 BN25xx / XC6190BC25xx

Ta=25°C

PARAMETER	SYMBOL	CONDITIONS	MIN	TYP	MAX	UNIT	CIRCUIT
Input Voltage Range	V _{IN}	-	1.75	-	6.00	V	③
UVLO Release Voltage	V _{UVLOR}	V _{IN} =SWEEP (step up), V _{SW1} =GND, V _{SW2} =GND	-	1.55	1.65	V	③
UVLO Detect Voltage ^(*)	V _{UVLO}	V _{IN} =SWEEP (step down), V _{SW1} =GND, V _{SW2} =GND	1.35	1.47	-	V	③
Quiescent Current	I _Q	V _{IN} =6.0V	-	0.01	0.10	μA	③
Operating Current ^(*)	I _{DD}	V _{IN} =6.0V, V _{SW1} =GND, V _{SW2} =GND	15.0	45.0	87.5	μA	③
Reboot Delay Time1 ^(*)	T _{DL1}	V _{SW1} =GND, V _{SW2} =GND	11.875	12.500	13.125	s	④
Reboot Delay Time2 ^(*)	T _{DL2}	V _{SW1} =GND, V _{SW2} =GND, V _{TS} =GND	7.125	7.500	7.875	s	④
Reboot Time ^(*)	T _{RSTB}	V _{SW1} =GND, V _{SW2} =GND *After T _{DL}	0.38	0.40	0.42	s	④
RSTB Pin SINK Current	I _{SINK}	V _{RSTB} =0.3V	30	-	-	mA	③
RSTB Pin SOURCE Current	I _{SOURCE}	XC6190BC25xx V _{RSTB} =V _{IN} -0.3V	20	-	-	mA	③
SW1 Pin "H" Voltage	V _{SW1H}	V _{IN} =6.0V	1.0	-	6.0	V	③
SW1 Pin "L" Voltage	V _{SW1L}	V _{IN} =6.0V	GND	-	0.3	V	③
SW1 Pin "H" Current	I _{SW1H}	V _{IN} =6.0V, V _{SW1} =6.0V	-0.1	-	0.1	μA	③
SW1 Pin "L" Current	I _{SW1L}	V _{IN} =6.0V, V _{SW1} =GND	3.5	7.5	16.0	μA	③
SW2 Pin "H" Voltage	V _{SW2H}	V _{IN} =6.0V	1.0	-	6.0	V	③
SW2 Pin "L" Voltage	V _{SW2L}	V _{IN} =6.0V	GND	-	0.3	V	③
SW2 Pin "H" Current	I _{SW2H}	V _{IN} =6.0V, V _{SW2} =6.0V	-0.1	-	0.1	μA	③
SW2 Pin "L" Current	I _{SW2L}	V _{IN} =6.0V, V _{SW2} =GND	3.5	7.5	16.0	μA	③

Unless otherwise stated, the reference is GND, V_{IN}=3.7V, V_{TS}=V_{IN}, SW1=open, SW2=open

(*) The UVLO detect voltage is less than the UVLO release voltage.

(*) Quiescent current until the reboot signal is output in the circuit operation state with the SW1, SW2 pin at "L" level

(*) Time from change of both SW1 and SW2 pin voltages to "L" level until the RSTB pin outputs "L" level ^(*).

(*) Time from change of RSTB pin to "L" level until RSTB pin changes to "H" level ^(*).

(*) RSTB pin "L" level is as follows: BN type: Applied voltage × 0.1 , BC type: V_{IN} × 0.1

(*) RSTB pin "H" level is as follows: BN type: Applied voltage × 0.9 , BC type: V_{IN} × 0.9

(Note) The following products are under development.

XC6190AC158R-G

■ TEST CIRCUIT(A Type)

1) Circuit ①

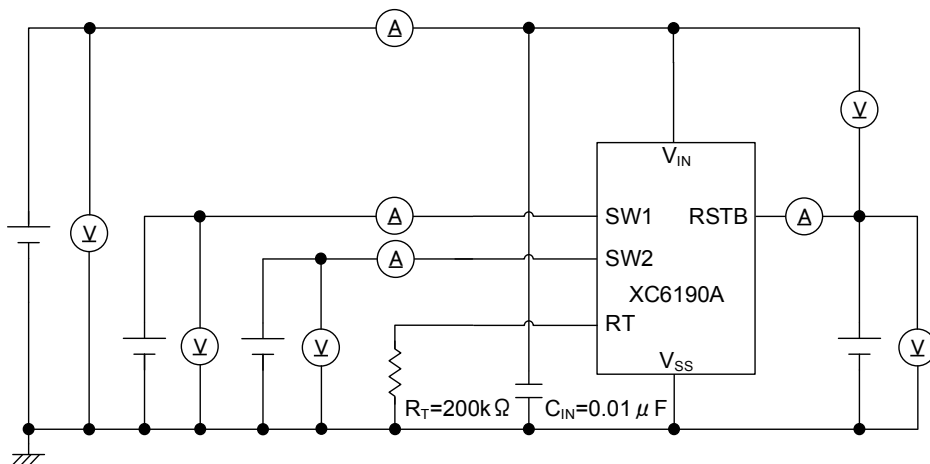

2) Circuit ②

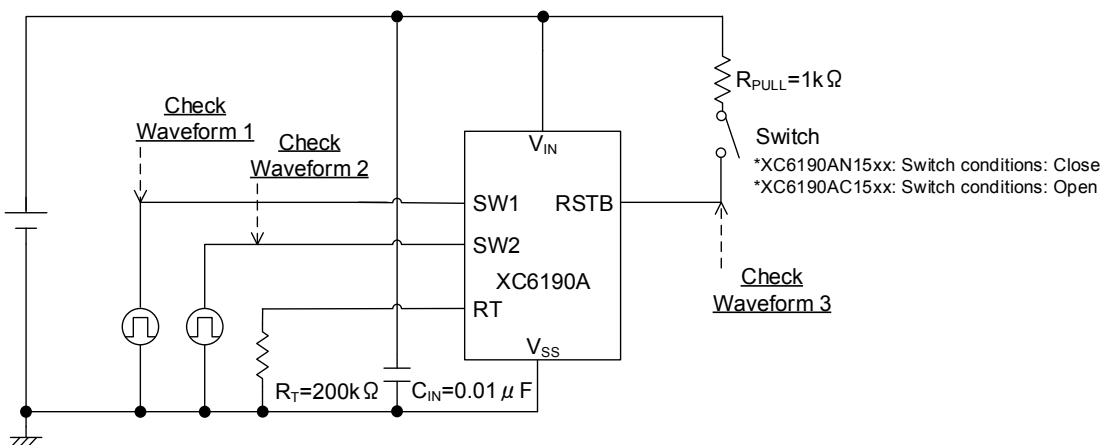

3) C_{IN}

PRODUCT NAME	DESCRIPTION
XC6190AN15xx	Connect at least C _{IN} = 0.01μF between V _{IN} pin - GND near the IC as needed.
XC6190AC15xx	Connect at least C _{IN} = 0.01μF between V _{IN} pin - GND near the IC.

(Note) The following products are under development.

XC6190AC158R-G

TEST CIRCUIT (Continued) (B Type)

1) Circuit ③

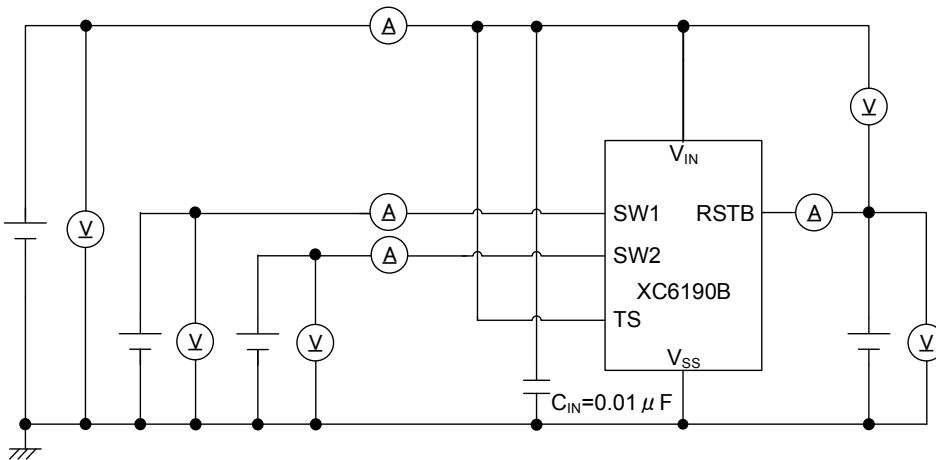

2) Circuit ④

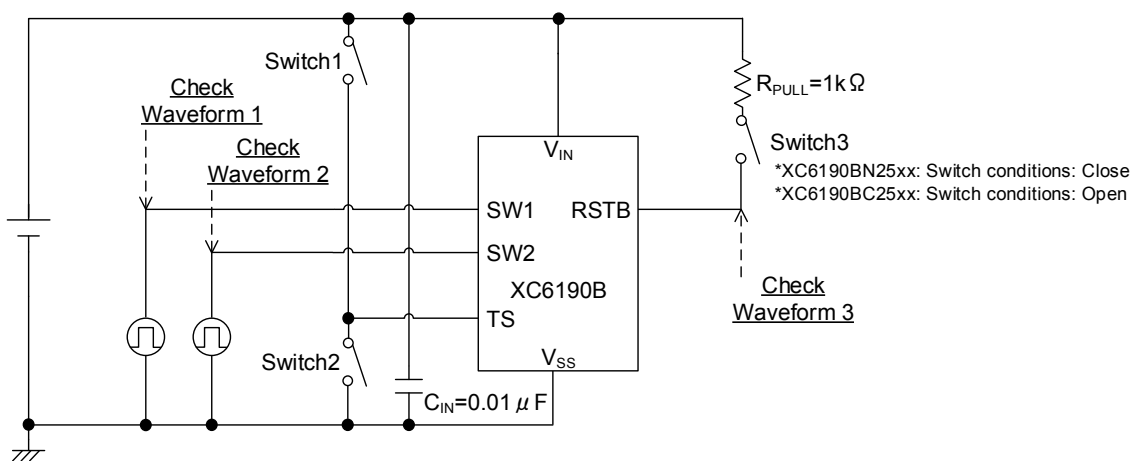

3) C_{IN}

PRODUCT NAME	DESCRIPTION
XC6190BN25xx	Connect at least C _{IN} = 0.01μF between V _{IN} pin - GND near the IC as needed.
XC6190BC25xx	Connect at least C _{IN} = 0.01μF between V _{IN} pin - GND near the IC.

(Note) The following products are under development.

XC6190AC158R-G

■ OPERATION EXPLANATION

The XC6190 series supplies a reboot signal (T_{RSTB} below) to the system by inputting “L” voltage into the SW1, SW2 pins for the set time (reboot delay time) using two switches (buttons)

On the XC6190AN15xx and XC6190AC15xx, a reboot delay time (T_{DL} below) is set by connecting a resistance (R_T below) to the RT pin.

T_{DL} is determined by the following calculation formula:

$$R_T(k\Omega) = \{ T_{DL}(s) - 0.097 \} / 0.062015$$

* Can be set within the range 1s to 20s.

e.g.) When $T_{DL}=12.5s$, $R_T=200k\Omega$

On the XC6190BN25xx and XC6190BC25xx, T_{DL} is determined by the internal circuitry. When the TS pin is shorted to V_{IN} , $T_{DL} = 12.5s$ (TYP.), and when the TS pin is shorted to GND, $T_{DL} = 7.5s$ (TYP.).

Even if the TS pin voltage changes from V_{IN} to GND while “L” voltage is input to the SW1 pin and SW2 pin, the value set prior to the change is maintained.

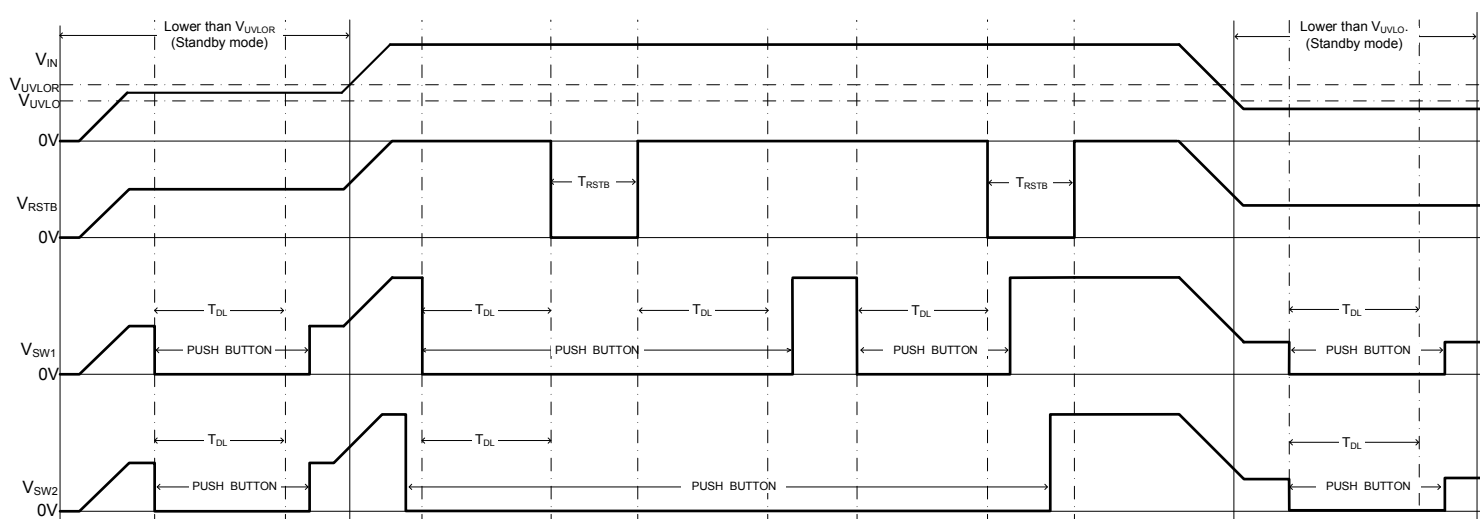

Fig.1 XC6190 Timing Chart

Details of each circuit part are as follows.

<SW1 pin, SW2 pin>

By inputting “L” voltage into both of these pins during the T_{DL} interval, the reboot signal is output from the RSTB pin.

Both pins are pulled up to V_{IN} by internal resistances, and thus the pin voltage when OPEN is V_{IN} level.

The UVLO circuit is activated by inputting “L” voltage into both the SW1 pin and SW2 pin.

<RT pin: Type A>

R_T is connected to this pin to set T_{DL} .

<TS pin: Type B>

This pin is used to set T_{DL} . When the TS pin is shorted to V_{IN} , T_{DL} is set to $T_{DL} = 12.5s$ (TYP.). When the TS pin is shorted to GND, T_{DL} is set to $T_{DL} = 7.5s$ (TYP.).

Even if the TS pin voltage is changed after “L” voltage is input into both the SW1 and SW2 pins and the internal circuit starts operation, the value set prior to the change is maintained.

(Note) The following products are under development.

XC6190AC158R-G

■ OPERATION EXPLANATION (Continued)

<UVLO>

This circuit prevents malfunctioning of the IC and allows internal circuit operation.

When it is detected that “L” voltage is input into both the SW1 and SW2 pins, the V_{IN} pin voltage is monitored.

When the V_{IN} pin voltage is higher than the UVLO release voltage, the UVLO circuit outputs a signal that allows internal circuit operation.

When the V_{IN} pin voltage is lower than the UVLO detect voltage, the UVLO circuit outputs a signal that puts the internal circuitry in the standby state.

When “H” voltage is input into the SW1 pin or SW2 pin (or both), the UVLO circuit does not operate and the internal circuitry enters the standby state.

<OSC IREF>

This is a current reference circuit for the OSC circuit.

The reference current of the XC6190AN15xx and XC6190AC15xx is set by RT connected to the RT pin.

The reference current of the XC6190BN25xx and XC6190BC25xx is fixed in the internal circuitry.

<OSC>

This is the reference oscillation circuit that uses the reference current of the OSC IREF circuit.

This circuit outputs an oscillation pulse signal that activates the Reboot Delay Counter and Reboot Counter.

< Reboot Delay Counter>

This circuit counts the oscillation pulse signal generated by the OSC circuit and generates the T_{DL} .

When the count ends, the circuit outputs a signal that puts the RSTB pin voltage at “L” level and a signal that starts the Reboot Counter.

If a signal from the UVLO circuit that changes the state to the standby state is detected during the count, the count returns to the initial state.

<Reboot Counter>

By counting the oscillation pulse signal generated by the OSC circuit, the reboot time (T_{RSTB}) is generated. The counting starts when it detects the start signal that is output from the Reboot Delay Counter.

If “H” voltage is input into the SW1 pin or SW2 pin (or both) during the count, the internal circuit does not change to the standby state until the count ends.

If a change-to-standby signal from the UVLO circuit is detected during the count, the count returns to the initial state.

When the count ends on the XC6190AN15xx and XC6190BN25xx, the circuit outputs a signal that puts the RSTB pin in the high-impedance state.

When the count ends on the XC6190AC15xx and XC6190BC25xx, the circuit outputs a signal that puts the RSTB pin at “H” level.

<Output driver>

The XC6190AN15xx and XC6190BN25xx are N-ch open drain output drivers. These drivers are in the OFF state when the Reboot Counter is not operating.

The XC6190AC15xx and XC6190BC25xx are CMOS output drivers. These drivers are in the “H” level state when the Reboot Counter is not operating.

Once the reboot signal output has taken place, “H” voltage must be input into the SW1 pin and SW2 pin (or both) in order to execute the reboot signal output again. After “H” voltage has been input, the reboot signal is output from the RSTB pin when “L” voltage is input into both the SW1 and SW2 pins and then T_{DL} elapses.

(Note) The following products are under development.

XC6190AC158R-G

■ NOTE ON USE

1. For temporary, transitional voltage drop or voltage rising phenomenon, the IC is liable to malfunction should the ratings be exceeded.
2. Please use this IC within the specified operating ranges.
3. On the XC6190AN15xx and XC6190BN25xx, sufficiently reinforce the $V_{IN} - GND$ line, as power noise may cause malfunctioning of the internal counter circuit. If necessary, connect a capacitor of at least $0.01\mu F$ between $V_{IN}-GND$ near the IC.
On the XC6190AC15xx and XC6190BC25xx, connect a capacitor of at least $0.01\mu F$ between $V_{IN}-GND$ near the IC.
4. Connection of any component other than a resistor to the RT pin is prohibited on the XC6190Axxxxx-G. This may cause malfunctioning.
Connect the external resistance (RT) between RT pin – GND near the IC.
5. When the mid voltage between “L” and “H” voltage is input into SW pin 1 and 2, the start-up and stop of the IC malfunction. So please pay attention to the external components so that the mid voltage between “L” and “H” is not input excessively and continuously to SW pin1 and 2.
6. When using for an application other than a push-button application, design the timing to include deviations and test sufficiently with the actual device before use.
7. Torex places an importance on improving our products and their reliability.
We request that users incorporate fail-safe designs and post-aging protection treatment when using Torex products in their systems.

(Note) The following products are under development.

XC6190AC158R-G

TYPICAL PERFORMANCE CHARACTERISTICS

(1) Quiescent Current vs. Input Voltage

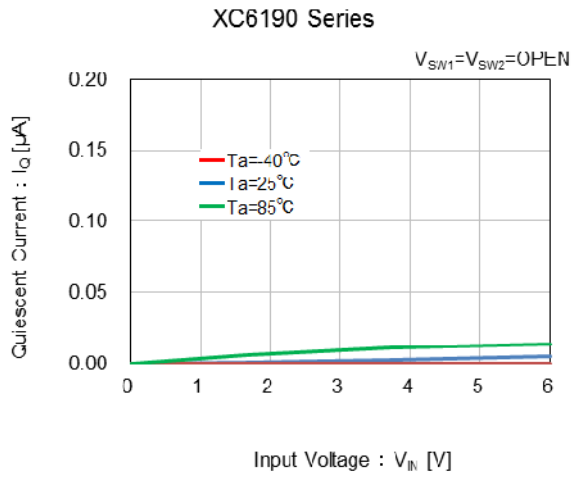

(2) Quiescent Current vs. Ambient Temperature

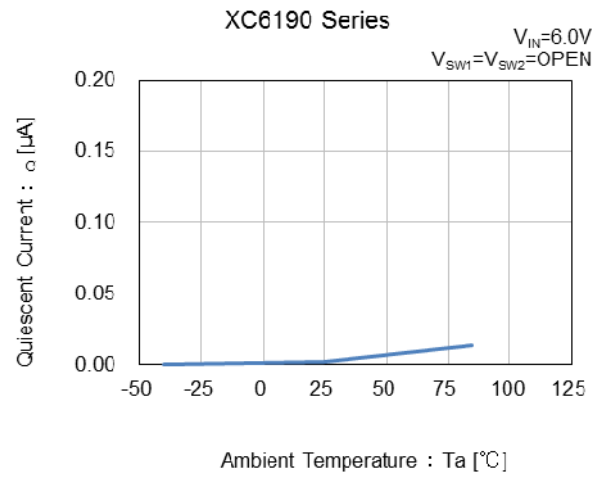

(3) Operating Current vs. Input Voltage : Type A

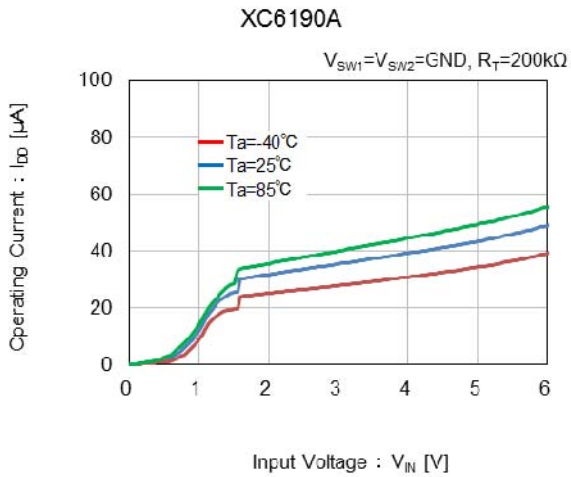

(4) Operating Current vs. Ambient Temperature : Type A

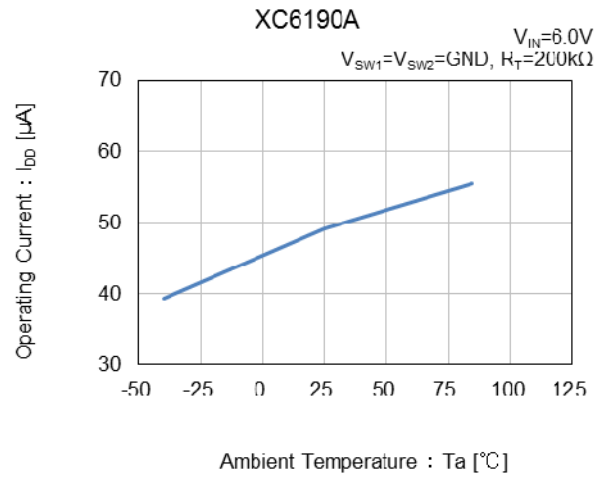

(5) Operating Current vs. Input Voltage : Type B

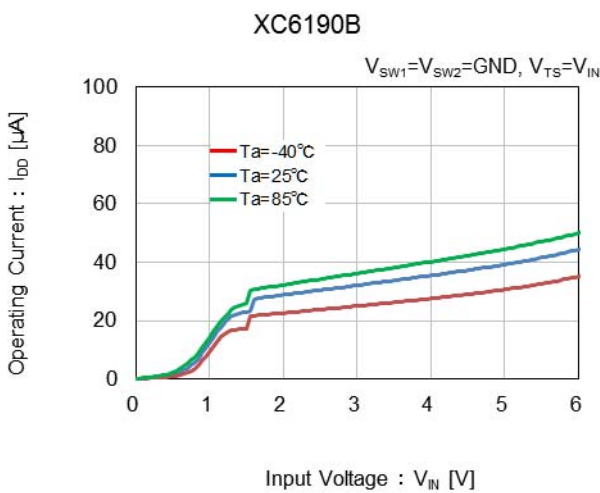

(6) Operating Current vs. Ambient Temperature : Type B

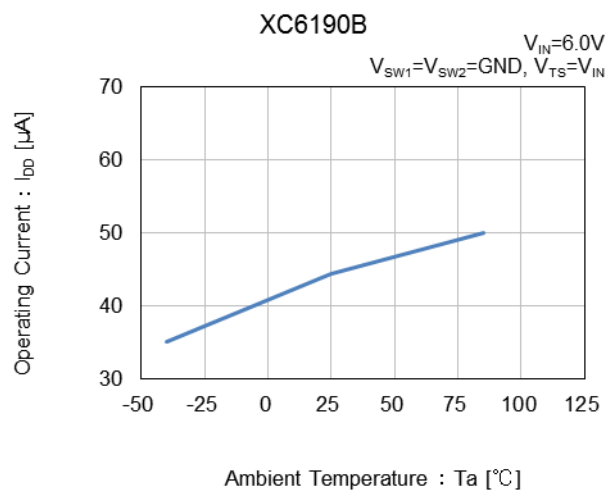

(Note) The following products are under development.

XC6190AC158R-G

■ TYPICAL PERFORMANCE CHARACTERISTICS (Continued)

(7) UVLO Release, Detect Voltage vs. Ambient Temperature

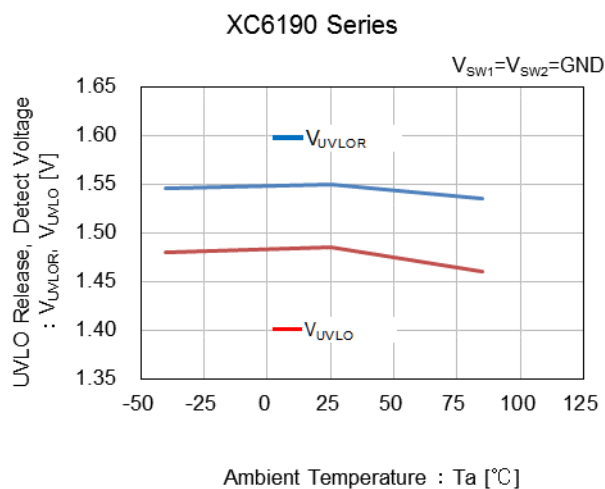

(8) SW1 Pin "H", "L" Voltage vs. Ambient Temperature

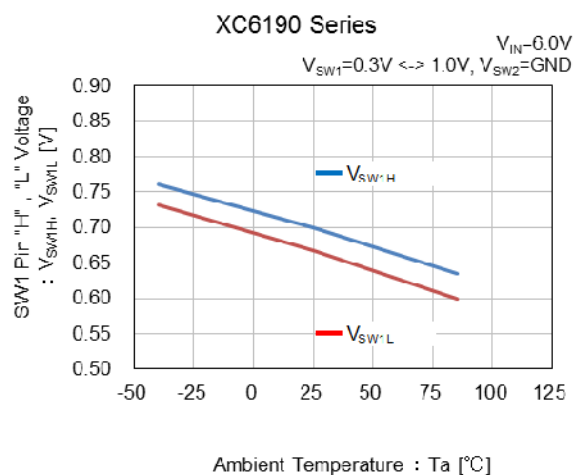

(10) SW2 Pin "H", "L" Voltage vs. Ambient Temperature

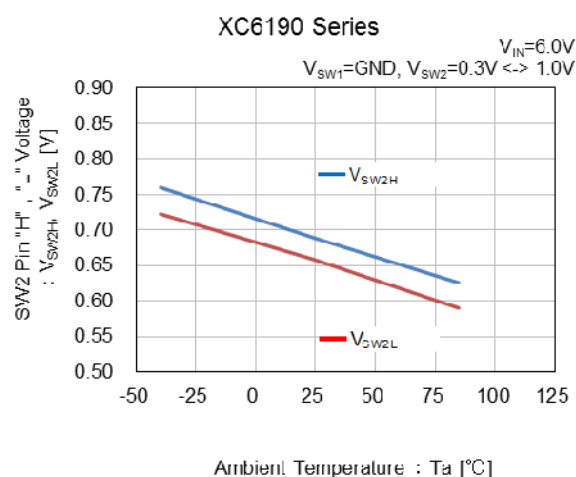

(9) SW1 Pin "L" Current vs. Ambient Temperature

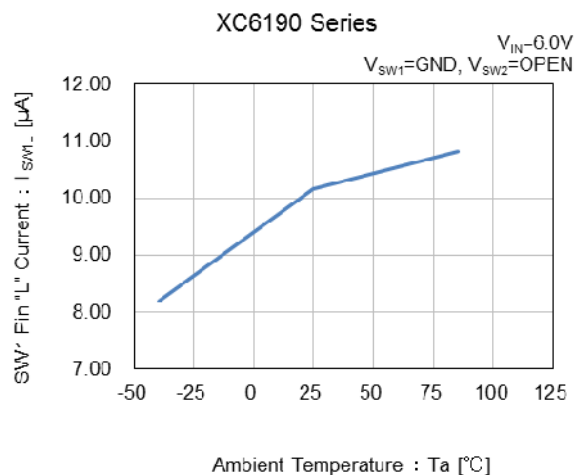

(11) SW2 Pin "L" Current vs. Ambient Temperature

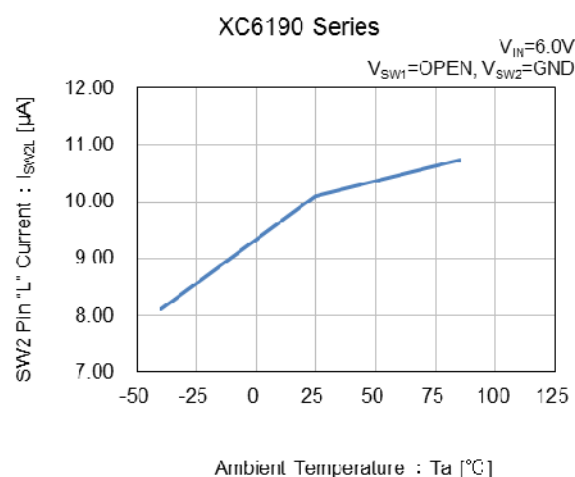

(Note) The following products are under development.

XC6190AC158R-G

TYPICAL PERFORMANCE CHARACTERISTICS (Continued)

(12) RSTB Pin SINK Current vs. Ambient Temperature

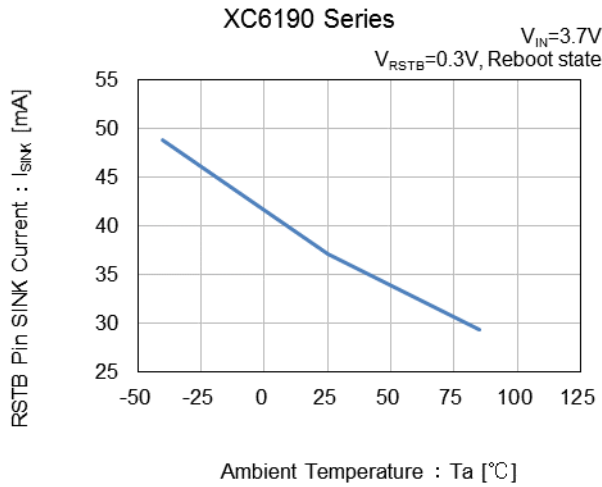

(13) RSTB Pin SOURCE Current vs. Ambient Temperature

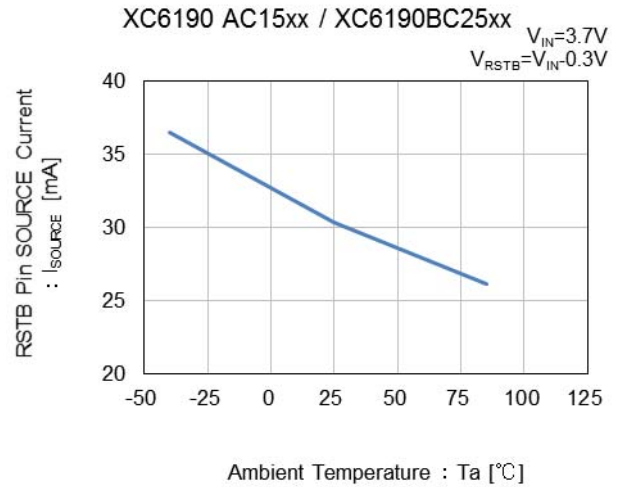

(14) Reboot Delay Time vs. Ambient Temperature :Type A

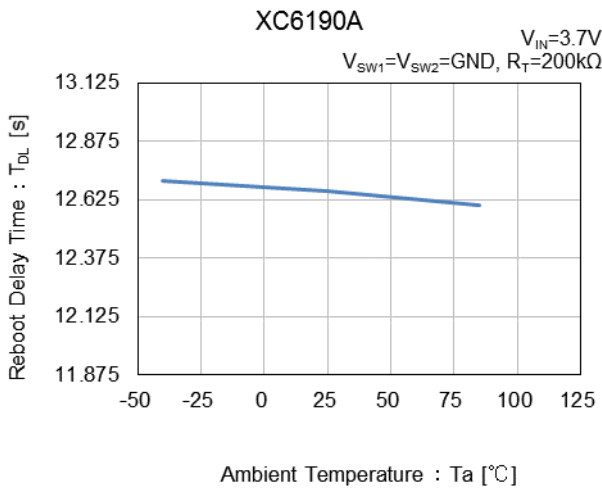

(15) Reboot Time vs. Ambient Temperature :Type A

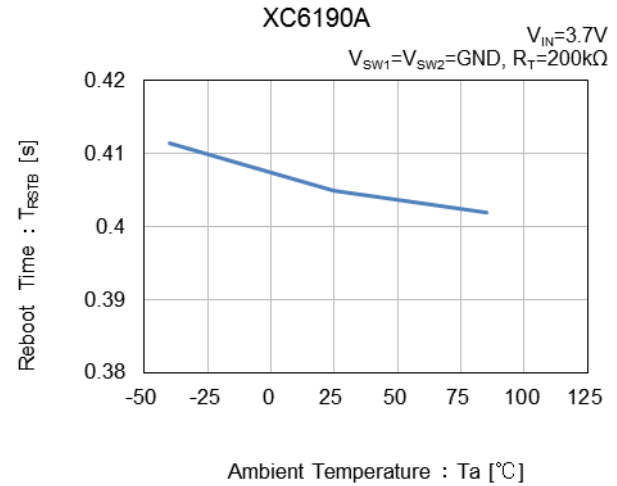

(16) Reboot Time vs. RT Resistance Value :Type A

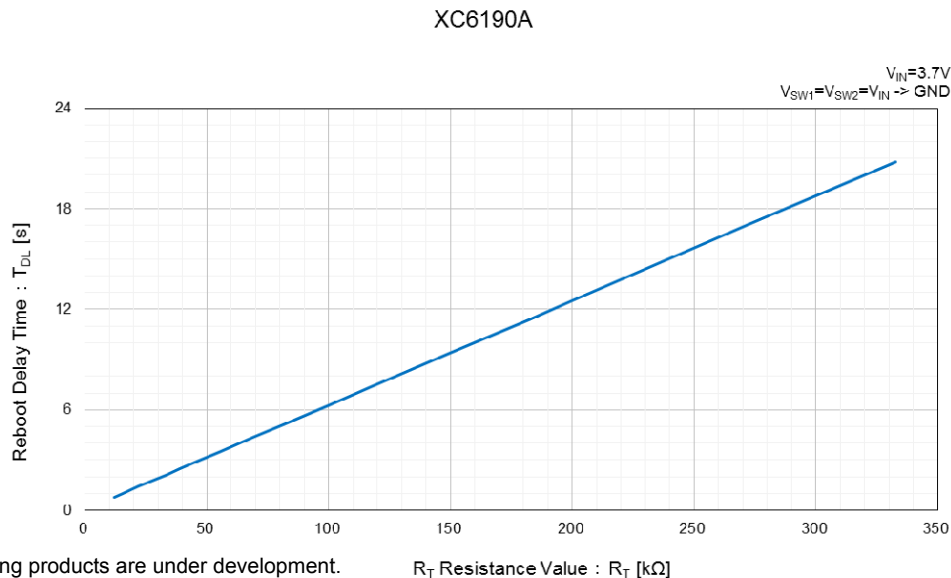

(Note) The following products are under development.

R_T Resistance Value : R_T [kΩ]

XC6190AC158R-G

■ TYPICAL PERFORMANCE CHARACTERISTICS (Continued)

(17) Reboot Delay Time 1 vs. Ambient Temperature :Type B

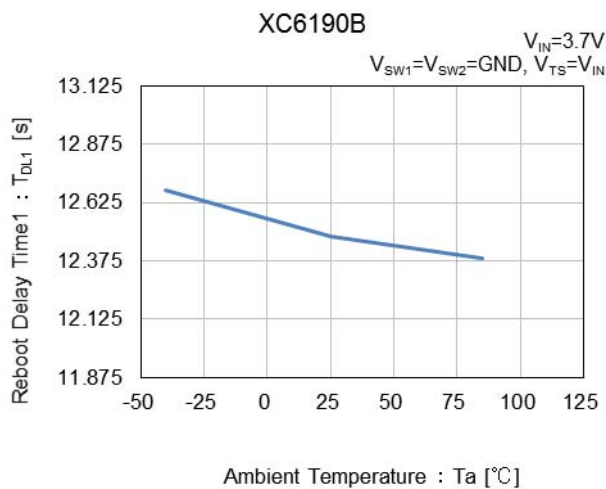

(18) Reboot Delay Time 2 vs. Ambient Temperature :Type B

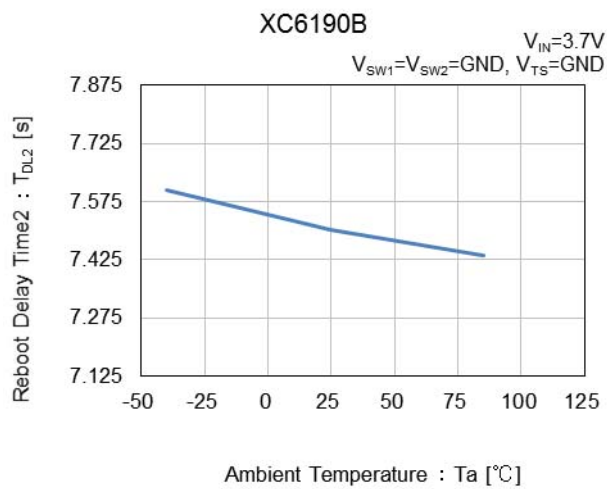

(19) Reboot Time vs. Ambient Temperature :Type B

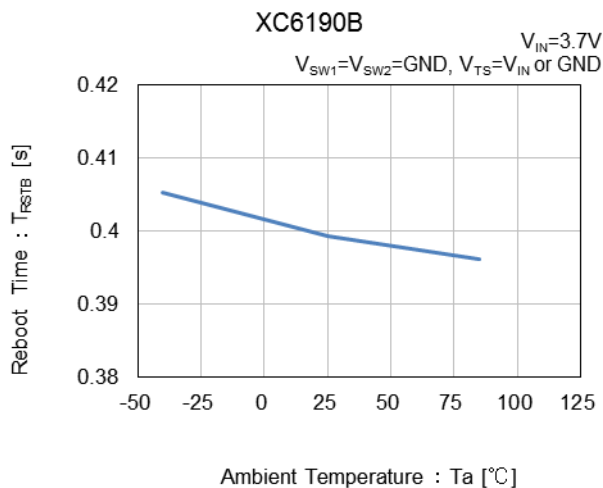

(Note) The following products are under development.

XC6190AC158R-G

PACKAGING INFORMATION

●USPN-6 (unit: mm)

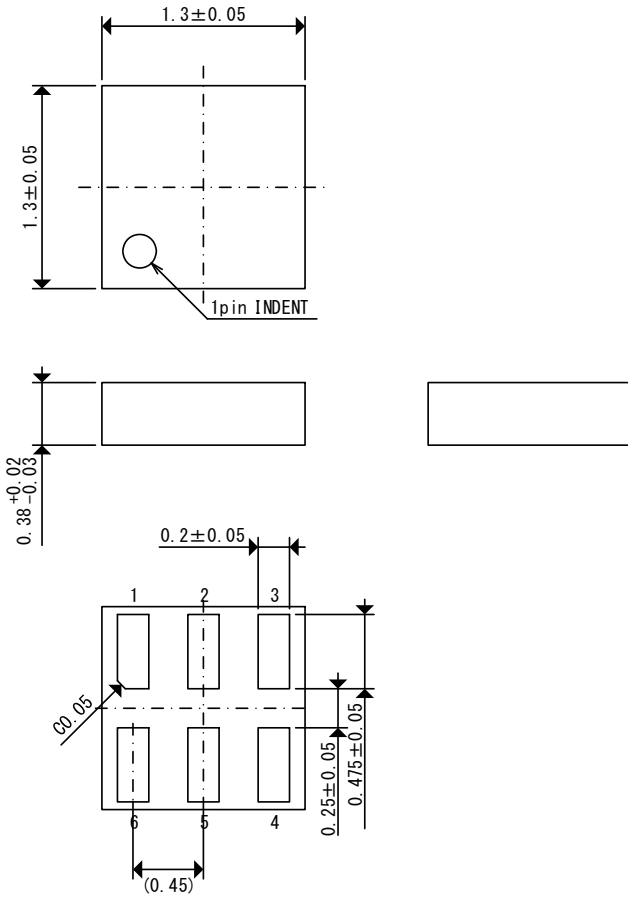

●USPN-6 reference pattern layout (unit: mm)

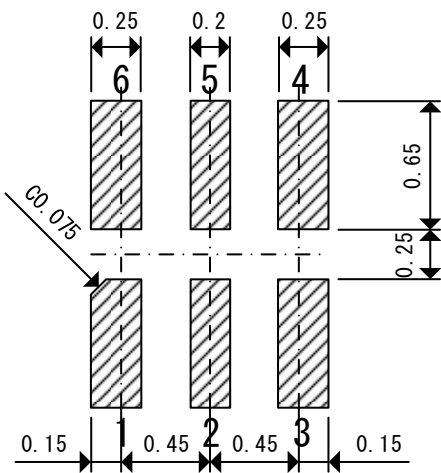

●USPN-6 reference metal mask design (unit: mm)

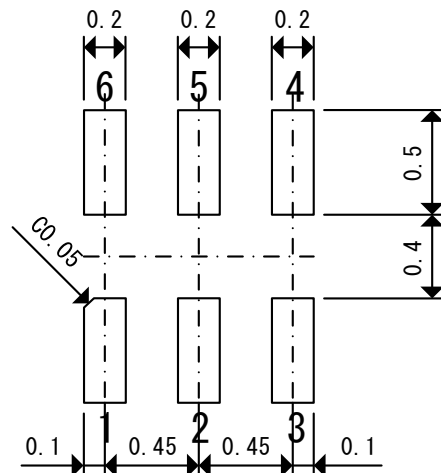

(Note) The following products are under development.

XC6190AC158R-G

PACKAGING INFORMATION (Continued)

●USPN-6B01 (unit: mm)

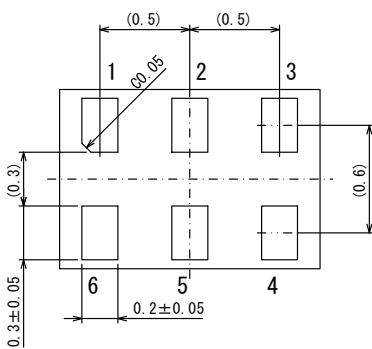
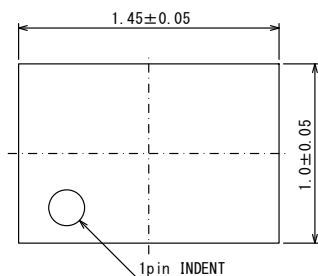

●USPN-6B01 reference pattern layout (unit: mm)

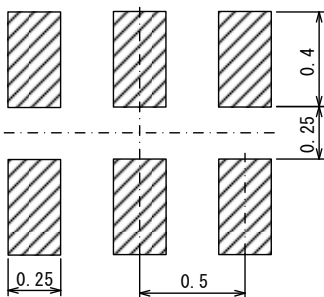

●USPN-6B01 reference metal mask design (unit:mm)

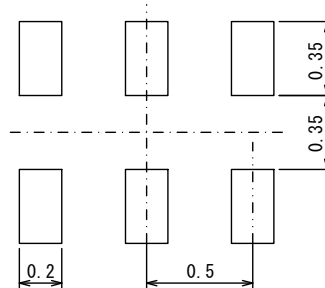

(Note) The following products are under development.

XC6190AC158R-G

MARKING RULE

●USPN-6 / USPN-6B01

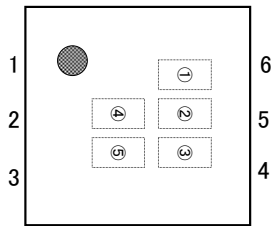

MARK ① represents product series

MARK	PRODUCT SERIES
A	XC6190*****-G

MARK ②

Standard product : Represents product type and output configuration

MARK	TYPE	OUTPUT CONFIGURATION	PRODUCT SERIES
1	A	N	XC6190AN****-G
2	A	C	XC6190AC****-G
3	B	N	XC6190BN****-G
4	B	C	XC6190BC****-G

MARK ③

Standard product : represents reboot delay time

MARK	DELAY TYPE	PRODUCT SERIES
1	1	XC6190**1***-G
2	2	XC6190**2***-G

MARK ④ & ⑤ represent production lot number

01~09, 0A~0Z, 11~9Z, A1~A9, AA~AZ, B1~ZZ

(G, I, J, O, Q, W excluded and no character inversion used)

(Note) The following products are under development.

XC6190AC158R-G

1. The products and product specifications contained herein are subject to change without notice to improve performance characteristics. Consult us, or our representatives before use, to confirm that the information in this datasheet is up to date.
2. We assume no responsibility for any infringement of patents, patent rights, or other rights arising from the use of any information and circuitry in this datasheet.
3. Please ensure suitable shipping controls (including fail-safe designs and aging protection) are in force for equipment employing products listed in this datasheet.
4. The products in this datasheet are not developed, designed, or approved for use with such equipment whose failure of malfunction can be reasonably expected to directly endanger the life of, or cause significant injury to, the user.
(e.g. Atomic energy; aerospace; transport; combustion and associated safety equipment thereof.)
5. Please use the products listed in this datasheet within the specified ranges.
Should you wish to use the products under conditions exceeding the specifications, please consult us or our representatives.
6. We assume no responsibility for damage or loss due to abnormal use.
7. All rights reserved. No part of this datasheet may be copied or reproduced without the prior permission of TOREX SEMICONDUCTOR LTD.

TOREX SEMICONDUCTOR LTD.