

TYCO ELECTRONICS RESERVES THE RIGHT TO AMEND THIS DRAWING AT ANY TIME.  
 USERS SHOULD EVALUATE THE SUITABILITY OF THE PRODUCT FOR THEIR APPLICATION.

REVISIONS			
LTR	DESCRIPTION	DATE	APPROVED
A	INITIAL RELEASE PER DCR# T-32062	OCTOBER/1/03	M.HIGGY
B	REVISED PER DCR# C050474	June/13/05	M.HIGGY

NOTES:

- THIS INSERT IS DESIGNED FOR USE IN TYCO/RAYCHEM CONNECTOR HOUSING MTC100-JH2-XXX. (SEE TYCO/RAYCHEM INFORMATION DRAWING D-659-0097 AND HOUSING SPECIFICATION CONTROL DRAWING FOR FURTHER DETAILS).
- PART DESCRIBED HEREON IS SUPPLIED AS SHOWN. REFER TO TYCO/RAYCHEM INFORMATION DRAWING D-659-0097 FOR CRIMP TOOLS OR ADDITIONAL CONTACTS, SEALING PLUGS OR TOOLS.
- GROMMET DESIGNED TO SEAL ON WIRES HAVING AN INSULATION DIAMETER OF 0.030 TO 0.065.
- PERFORMANCE:  
THIS PRODUCT IS DESIGNED TO MEET THE APPLICABLE REQUIREMENTS OF RAYCHEM SPECIFICATION C-6115.
- MATERIALS:  
 A) PLASTIC INSERT HIGH GRADE POLYARYLENE THERMOPLASTIC  
 B) GROMMET FLUOROSILICONE PER MIL-R-25988  
 C) RETENTION CLIPS (20) BERYLLIUM COPPER 172 PER ASTM B194  
 (INSIDE PLASTIC INSERT)

If this document is printed it becomes uncontrolled.  
 Check for the latest revision.

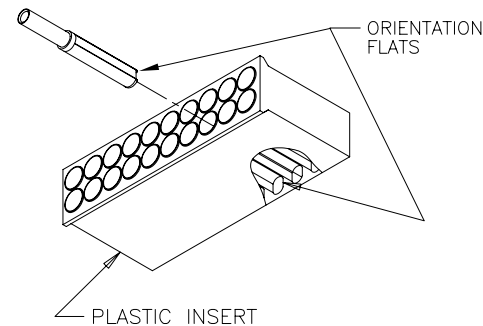

6 PART NUMBER, RAYCHEM, B, DATE CODE AND ORIENTATION MARK ARE STAMPED APPROXIMATELY AS SHOWN.

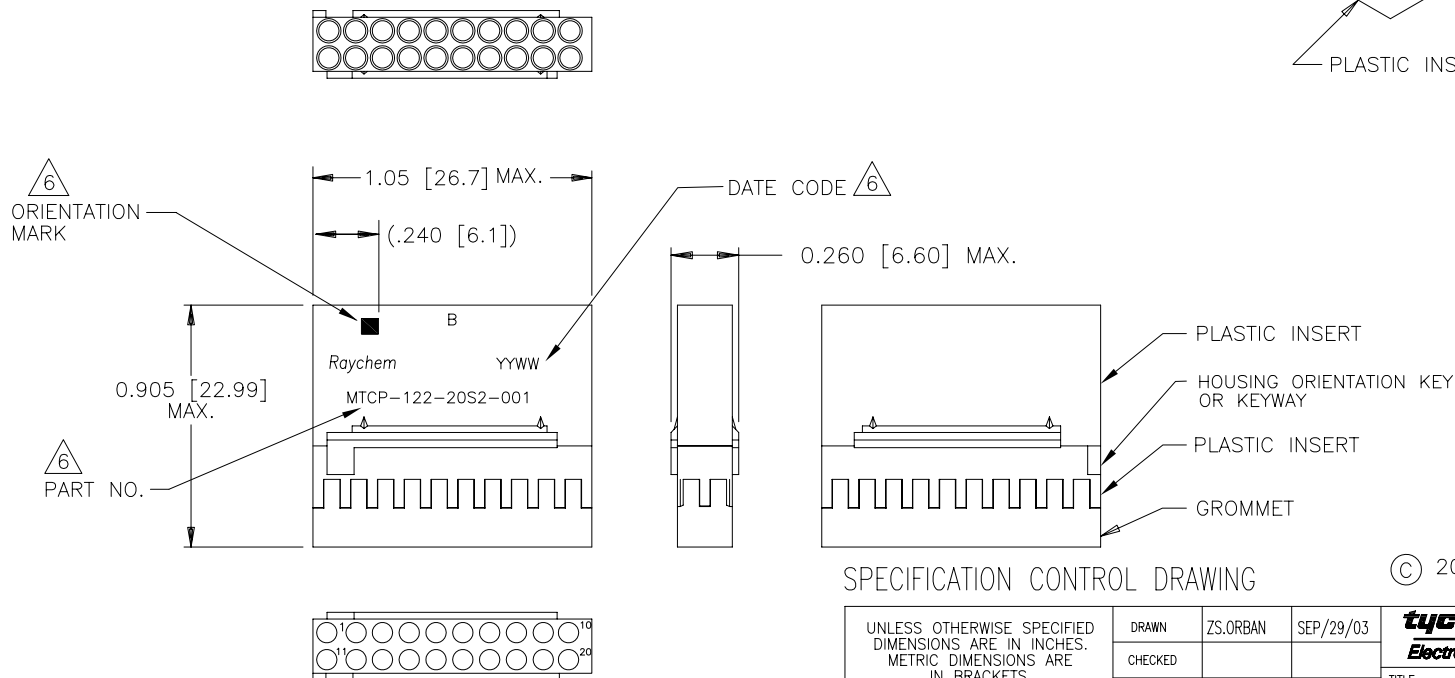

SPECIFICATION CONTROL DRAWING

© 2005 Tyco Electronics Corporation.  
 All rights reserved

UNLESS OTHERWISE SPECIFIED DIMENSIONS ARE IN INCHES. METRIC DIMENSIONS ARE IN BRACKETS.  DECIMALS .XXX ± .XX ± N/A } mm ANGLES .X ±  WEIGHT 2.80 g MAX.	DRAWN	ZS.ORBAN	SEP/29/03		TYCO ELECTRONICS 300 Constitution Drive Menlo Park, CA. 94025 USA								
	CHECKED												
	APPROVED			TITLE	INSERT, SOCKET, SECONDARY, 20 CAVITY, SIZE 22-20 REMOVABLE CONTACT 2 INCH CONNECTOR SPECIAL MARKING-MTC100 SERIES								
	APPROVED	M.HIGGY	SEP/29/03	CAD NAME	C050474.DWG	<table border="1"> <tr> <td>SIZE</td> <td>CAGE CODE:</td> <td>DWG. NO.</td> <td>REV</td> </tr> <tr> <td>A</td> <td>06090</td> <td>MTCP-122-20S2-001</td> <td>B</td> </tr> </table>	SIZE	CAGE CODE:	DWG. NO.	REV	A	06090	MTCP-122-20S2-001
SIZE	CAGE CODE:	DWG. NO.	REV										
A	06090	MTCP-122-20S2-001	B										

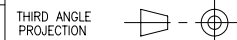

DO NOT SCALE THIS DRAWING	SHEET 1 OF 1	
---------------------------	--------------	--

DWG. NO. MTCP-122-20S2-001 SHEET 1