

DATE	DESCRIPTION	REV.
1.16.07	CHANGE AS PER ECN 07-004	A
3.29.12	CHANGE AS PER ECN 12-040	B
10.24.18	CHANGE AS PER ECN 18-043	C

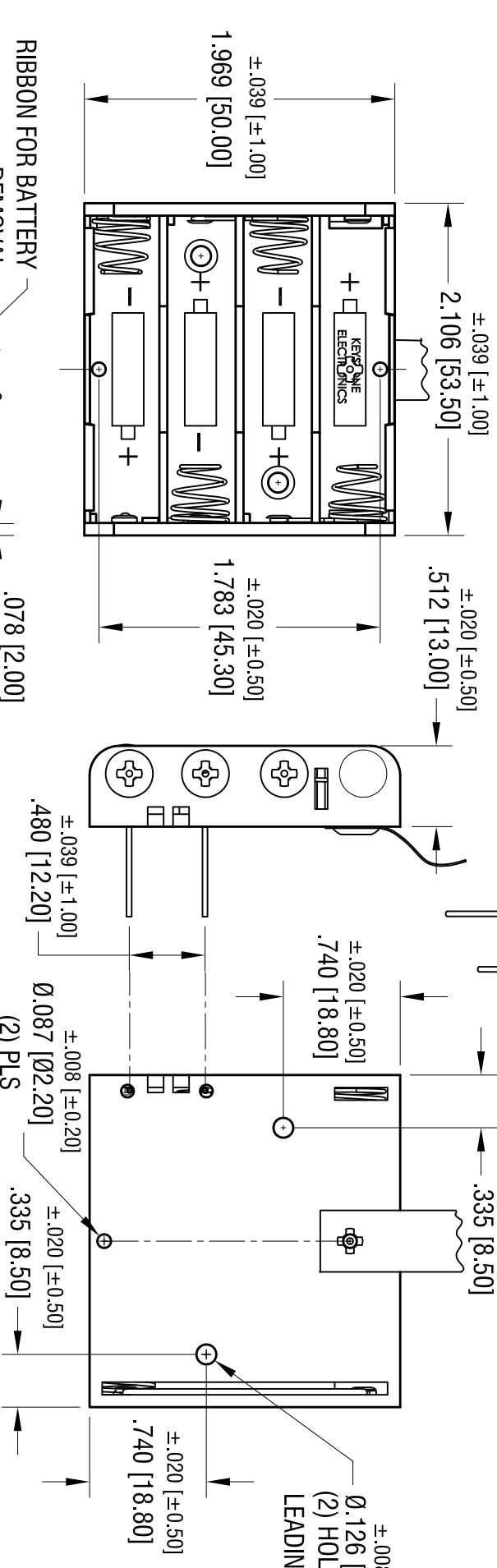

NOTE:
 1. HOLDER: MAT'L: POLYPROPYLENE
 2. SPRING: MAT'L: MUSIC WIRE, .024 [0.60] DIA.
 3. PC TERMINALS: MAT'L: BRASS, .032 [0.81] DIA.
 4. RIBBON: MAT'L: NYLON, RED

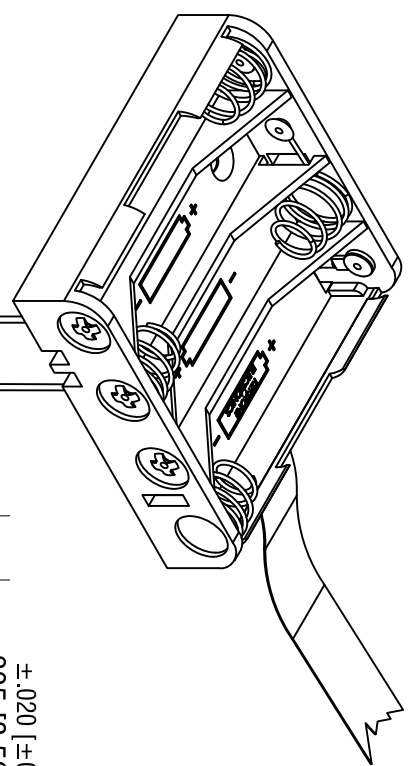
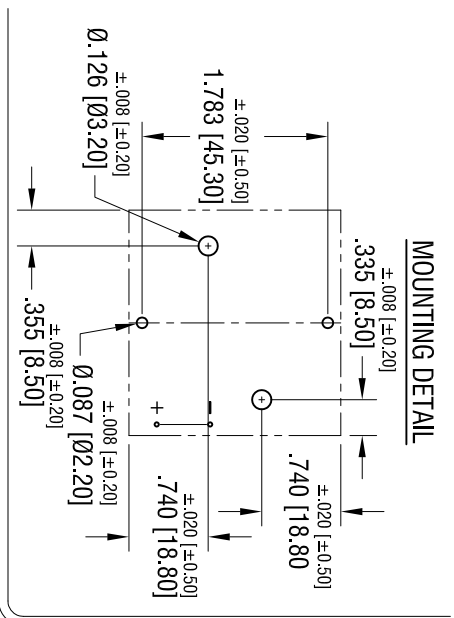

THIS DOCUMENT IS THE PROPERTY OF KEYSTONE ELECTRONICS CORP. AND SHALL NOT BE REPRODUCED, DISTRIBUTED OR USED AS A BASIS FOR MANUFACTURE WITHOUT PRIOR WRITTEN PERMISSION FROM KEYSTONE ELECTRONICS CORP.

KEYSTONE ELECTRONICS CORP.
 www.keystone.com • NEW HYDE PARK, NY 11040 • Tel: (516) 328-7500

PART NAME: PC BATTERY HOLDER (4) 'AAA' W/ RIBBON

MATERIAL: AS NOTED

FINISH: NICKEL PLATE

TOLERANCES	INCH	[MM]	CODE	DRN BY	DATE
DECIMAL	± 0.15	[± 0.38]	C	BOONE	12.01.03
ANGULAR	± 1°			LN	SCALE 1X

DWG NO. 2481RB