

THIS DRAWING IS UNPUBLISHED. RELEASED FOR PUBLICATION 20
 © COPYRIGHT 20 BY - ALL RIGHTS RESERVED.

REVISIONS

P	LTR	DESCRIPTION	DATE	DWN	APVD
A		INITIAL	07Jan2015	GY	CW
B		ECR-15-013759	28SEP2015	DW	CW

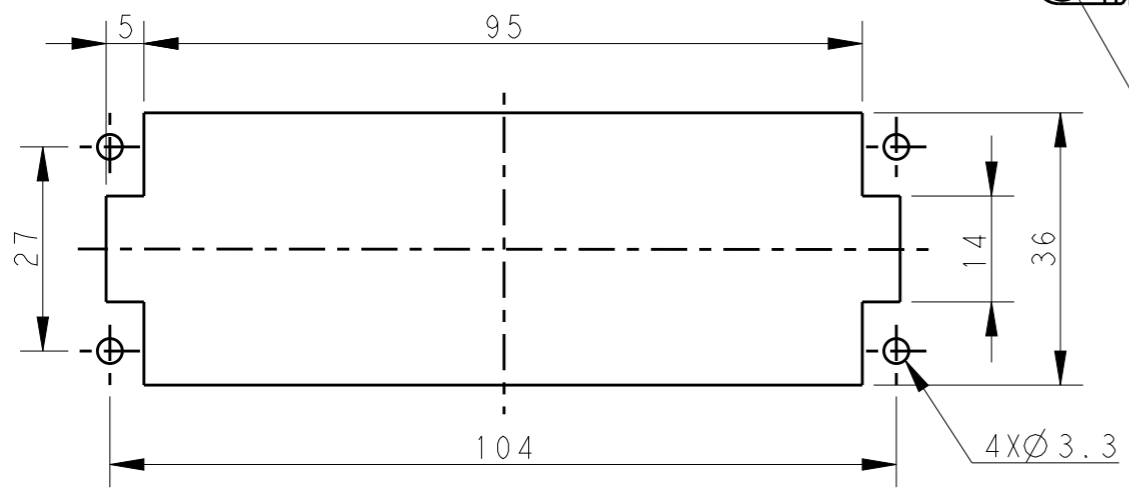
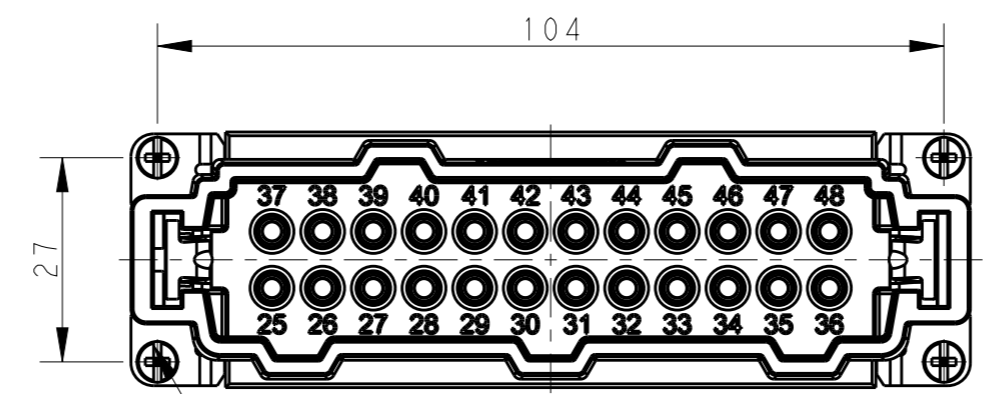
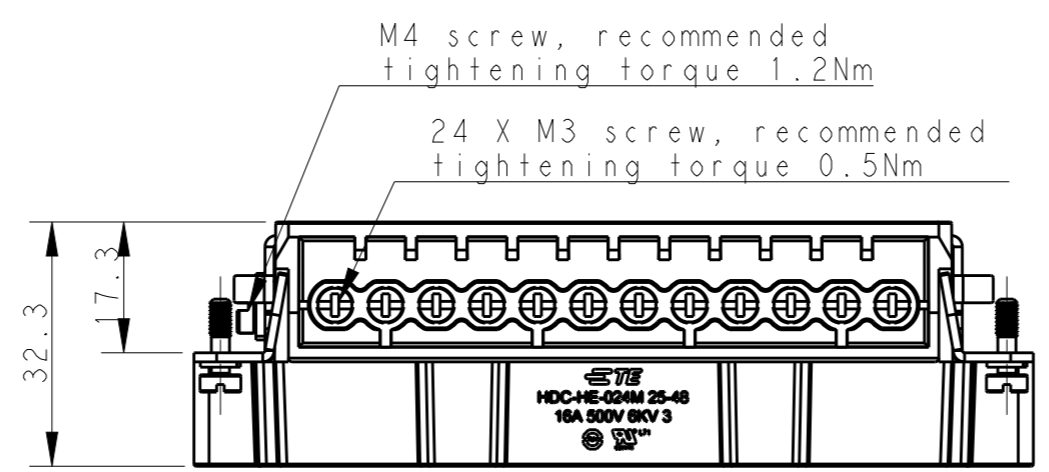
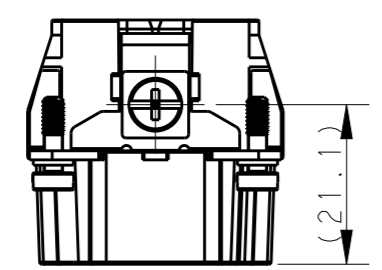
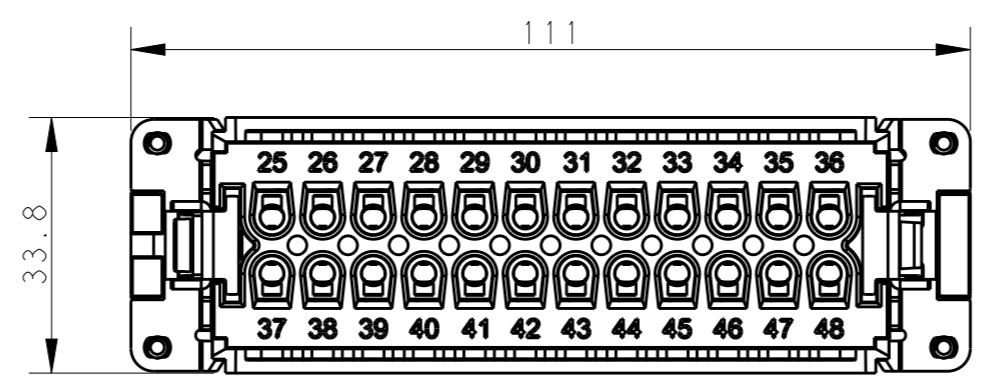
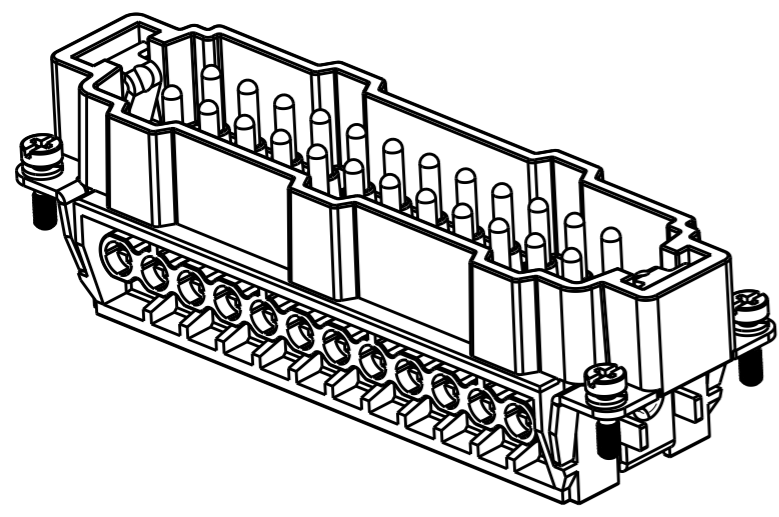

NOTES:

- TECHNICAL CHARACTERISTICS:
 INSULATION MATERIAL: PC
 RATED VOLTAGE: 500V
 RATED CURRENT: 16A
 INSULATION RESISTANCE: $\geq 400M\Omega$
 RATED IMPULSE VOLTAGE: 6KV
 POLLUTION DEGREE: 3
 FLAMMABILITY: UL94V-0
 MATING CYCLES: 500 CYCLES
 OPERATION TEMPERATURE: $-40^{\circ}C \sim +125^{\circ}C$
 WIRE RANGE: $0.5mm^2 \sim 2.5mm^2$ (AWG20-AWG14)
 CONTACT TYPE: SCREW CLAMP (M3)

注释:

- 技术参数:
 绝缘材料: PC
 额定电压: 500V
 额定电流: 16A
 绝缘电阻: $\geq 400M\Omega$
 脉冲电压: 6KV
 污染等级: 3
 阻燃等级: UL94V-0
 插拔次数: 500 次
 工作温度: $-40^{\circ}C \sim +125^{\circ}C$
 接线范围: $0.5mm^2 \sim 2.5mm^2$ (AWG20-AWG14)
 接线类型: 螺丝压接 (M3)

HE-024-M 25-48	T2040482101-000
DESCRIPTION	PART NUMBER

THIS DRAWING IS A CONTROLLED DOCUMENT.		DWN	Gino.Yao	06Jan2015	 TE Connectivity NAME HE-024-M 25-48				
DIMENSIONS: mm		CHK	Chris.Wang	06Jan2015					
TOLERANCES UNLESS OTHERWISE SPECIFIED:		APVD	Xiang.Xu	06Jan2015					
0 PLC ±- 1 PLC ±- 2 PLC ±- 3 PLC ±- 4 PLC ±- ANGLES ±-		PRODUCT SPEC	108-137044						
MATERIAL	FINISH	APPLICATION SPEC	114-137044		SIZE	CAGE CODE	DRAWING NO	RESTRICTED TO	
-	-	WEIGHT	-		A3	00779	©-T2040482101000	-	
CUSTOMER DRAWING				SCALE	1:1	SHEET	1 OF 1	REV	B