

iNEMO inertial module: always-on 3D accelerometer and 3D gyroscope

Datasheet - production data

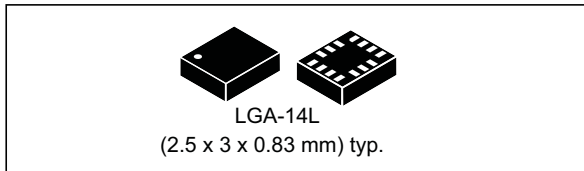

Features

- “Always-on” experience with low power consumption for both accelerometer and gyroscope
- Power consumption: 0.4 mA in combo normal mode and 0.65 mA in combo high-performance mode
- Smart FIFO up to 4 kbyte based on features set
- Android M compliant
- Auxiliary SPI for OIS data output for gyroscope and accelerometer
- Hard, soft ironing for external magnetic sensor corrections
- $\pm 2/\pm 4/\pm 8/\pm 16$ g full scale
- $\pm 125/\pm 250/\pm 500/\pm 1000/\pm 2000$ dps full scale
- Analog supply voltage: 1.71 V to 3.6 V
- SPI & I²C serial interface with main processor data synchronization
- Dedicated gyroscope low-pass filters for UI and OIS applications
- Smart embedded functions: pedometer, step detector and step counter, significant motion and tilt
- Standard interrupts: free-fall, wakeup, 6D/4D orientation, click and double-click
- Embedded temperature sensor
- ECOPACK[®], RoHS and “Green” compliant

Applications

- Motion tracking and gesture detection
- Sensor hub
- Indoor navigation
- IoT and connected devices
- Smart power saving for handheld devices
- EIS and OIS for camera applications
- Vibration monitoring and compensation

Description

The LSM6DSM is a system-in-package featuring a 3D digital accelerometer and a 3D digital gyroscope performing at 0.65 mA in high-performance mode and enabling always-on low-power features for an optimal motion experience for the consumer.

The LSM6DSM supports main OS requirements, offering real, virtual and batch sensors with 4 kbyte for dynamic data batching.

ST’s family of MEMS sensor modules leverages the robust and mature manufacturing processes already used for the production of micromachined accelerometers and gyroscopes.

The various sensing elements are manufactured using specialized micromachining processes, while the IC interfaces are developed using CMOS technology that allows the design of a dedicated circuit which is trimmed to better match the characteristics of the sensing element.

The LSM6DSM has a full-scale acceleration range of $\pm 2/\pm 4/\pm 8/\pm 16$ g and an angular rate range of $\pm 125/\pm 250/\pm 500/\pm 1000/\pm 2000$ dps.

The LSM6DSM fully supports EIS and OIS applications as the module includes a dedicated configurable signal processing path for OIS and auxiliary SPI configurable for both the gyroscope and accelerometer.

High robustness to mechanical shock makes the LSM6DSM the preferred choice of system designers for the creation and manufacturing of reliable products.

The LSM6DSM is available in a plastic land grid array (LGA) package.

Table 1. Device summary

Part number	Temp. range [°C]	Package	Packing
LSM6DSM	-40 to +85	LGA-14L (2.5x3x0.83mm)	Tray
LSM6DSMTR	-40 to +85		Tape & Reel

Contents

- 1 Overview 17**
- 2 Embedded low-power features 18**
 - 2.1 Tilt detection 18
 - 2.2 Absolute wrist tilt 19
- 3 Pin description 20**
 - 3.1 Pin connections 21
- 4 Module specifications 23**
 - 4.1 Mechanical characteristics 23
 - 4.2 Electrical characteristics 26
 - 4.3 Temperature sensor characteristics 27
 - 4.4 Communication interface characteristics 28
 - 4.4.1 SPI - serial peripheral interface 28
 - 4.4.2 I²C - inter-IC control interface 29
 - 4.5 Absolute maximum ratings 31
 - 4.6 Terminology 32
 - 4.6.1 Sensitivity 32
 - 4.6.2 Zero-g and zero-rate level 32
- 5 Functionality 33**
 - 5.1 Operating modes 33
 - 5.2 Gyroscope power modes 33
 - 5.3 Accelerometer power modes 33
 - 5.4 Block diagram of filters 34
 - 5.4.1 Block diagrams of the gyroscope filters 34
 - 5.4.2 Block diagrams of the accelerometer filters 36
 - 5.5 FIFO 38
 - 5.5.1 Bypass mode 38
 - 5.5.2 FIFO mode 39
 - 5.5.3 Continuous mode 39
 - 5.5.4 Continuous-to-FIFO mode 39

	5.5.5	Bypass-to-Continuous mode	39
	5.5.6	FIFO reading procedure	40
6		Digital interfaces	41
	6.1	I ² C/SPI interface	41
	6.2	Master I ² C	41
	6.3	Auxiliary SPI	42
	6.4	I ² C serial interface	42
	6.4.1	I ² C operation	42
	6.5	SPI bus interface	45
	6.5.1	SPI read	46
	6.5.2	SPI write	47
	6.5.3	SPI read in 3-wire mode	48
7		Application hints	49
	7.1	LSM6DSM electrical connections in Mode 1	49
	7.2	LSM6DSM electrical connections in Mode 2	50
	7.3	LSM6DSM electrical connections in Mode 3 and Mode 4	51
8		Auxiliary SPI configurations	55
	8.1	Gyroscope filtering	55
	8.2	Accelerometer filtering	56
	8.2.1	Accelerometer full scale set from primary interface	56
	8.2.2	Accelerometer full scale set from auxiliary SPI	56
9		Register mapping	57
10		Register description	61
	10.1	FUNC_CFG_ACCESS (01h)	61
	10.2	SENSOR_SYNC_TIME_FRAME (04h)	61
	10.3	SENSOR_SYNC_RES_RATIO (05h)	62
	10.4	FIFO_CTRL1 (06h)	62
	10.5	FIFO_CTRL2 (07h)	63
	10.6	FIFO_CTRL3 (08h)	64
	10.7	FIFO_CTRL4 (09h)	65

10.8	FIFO_CTRL5 (0Ah)	66
10.9	DRDY_PULSE_CFG (0Bh)	67
10.10	INT1_CTRL (0Dh)	67
10.11	INT2_CTRL (0Eh)	68
10.12	WHO_AM_I (0Fh)	68
10.13	CTRL1_XL (10h)	69
10.14	CTRL2_G (11h)	70
10.15	CTRL3_C (12h)	71
10.16	CTRL4_C (13h)	72
10.17	CTRL5_C (14h)	72
10.18	CTRL6_C (15h)	74
10.19	CTRL7_G (16h)	75
10.20	CTRL8_XL (17h)	75
10.21	CTRL9_XL (18h)	76
10.22	CTRL10_C (19h)	77
10.23	MASTER_CONFIG (1Ah)	77
10.24	WAKE_UP_SRC (1Bh)	78
10.25	TAP_SRC (1Ch)	79
10.26	D6D_SRC (1Dh)	79
10.27	STATUS_REG/STATUS_SPIAux (1Eh)	80
10.28	OUT_TEMP_L (20h), OUT_TEMP_H (21h)	80
10.29	OUTX_L_G (22h)	81
10.30	OUTX_H_G (23h)	81
10.31	OUTY_L_G (24h)	82
10.32	OUTY_H_G (25h)	82
10.33	OUTZ_L_G (26h)	83
10.34	OUTZ_H_G (27h)	83
10.35	OUTX_L_XL (28h)	84
10.36	OUTX_H_XL (29h)	84
10.37	OUTY_L_XL (2Ah)	84
10.38	OUTY_H_XL (2Bh)	85
10.39	OUTZ_L_XL (2Ch)	85
10.40	OUTZ_H_XL (2Dh)	85

10.41	SENSORHUB1_REG (2Eh)	85
10.42	SENSORHUB2_REG (2Fh)	86
10.43	SENSORHUB3_REG (30h)	86
10.44	SENSORHUB4_REG (31h)	86
10.45	SENSORHUB5_REG (32h)	86
10.46	SENSORHUB6_REG (33h)	87
10.47	SENSORHUB7_REG (34h)	87
10.48	SENSORHUB8_REG (35h)	87
10.49	SENSORHUB9_REG (36h)	87
10.50	SENSORHUB10_REG (37h)	88
10.51	SENSORHUB11_REG (38h)	88
10.52	SENSORHUB12_REG (39h)	88
10.53	FIFO_STATUS1 (3Ah)	88
10.54	FIFO_STATUS2 (3Bh)	89
10.55	FIFO_STATUS3 (3Ch)	89
10.56	FIFO_STATUS4 (3Dh)	90
10.57	FIFO_DATA_OUT_L (3Eh)	90
10.58	FIFO_DATA_OUT_H (3Fh)	90
10.59	TIMESTAMP0_REG (40h)	91
10.60	TIMESTAMP1_REG (41h)	91
10.61	TIMESTAMP2_REG (42h)	91
10.62	STEP_TIMESTAMP_L (49h)	91
10.63	STEP_TIMESTAMP_H (4Ah)	92
10.64	STEP_COUNTER_L (4Bh)	92
10.65	STEP_COUNTER_H (4Ch)	92
10.66	SENSORHUB13_REG (4Dh)	92
10.67	SENSORHUB14_REG (4Eh)	93
10.68	SENSORHUB15_REG (4Fh)	93
10.69	SENSORHUB16_REG (50h)	93
10.70	SENSORHUB17_REG (51h)	93
10.71	SENSORHUB18_REG (52h)	94
10.72	FUNC_SRC1 (53h)	94
10.73	FUNC_SRC2 (54h)	95

10.74	WRIST_TILT_IA (55h)	95
10.75	TAP_CFG (58h)	96
10.76	TAP_THS_6D (59h)	97
10.77	INT_DUR2 (5Ah)	97
10.78	WAKE_UP_THS (5Bh)	98
10.79	WAKE_UP_DUR (5Ch)	98
10.80	FREE_FALL (5Dh)	99
10.81	MD1_CFG (5Eh)	100
10.82	MD2_CFG (5Fh)	101
10.83	MASTER_CMD_CODE (60h)	102
10.84	SENS_SYNC_SPI_ERROR_CODE (61h)	102
10.85	OUT_MAG_RAW_X_L (66h)	102
10.86	OUT_MAG_RAW_X_H (67h)	102
10.87	OUT_MAG_RAW_Y_L (68h)	103
10.88	OUT_MAG_RAW_Y_H (69h)	103
10.89	OUT_MAG_RAW_Z_L (6Ah)	103
10.90	OUT_MAG_RAW_Z_H (6Bh)	103
10.91	INT_OIS (6Fh)	104
10.92	CTRL1_OIS (70h)	104
10.93	CTRL2_OIS (71h)	105
10.94	CTRL3_OIS (72h)	106
10.95	X_OFS_USR (73h)	107
10.96	Y_OFS_USR (74h)	107
10.97	Z_OFS_USR (75h)	107
11	Embedded functions register mapping	108
12	Embedded functions registers description - Bank A	110
12.1	SLV0_ADD (02h)	110
12.2	SLV0_SUBADD (03h)	110
12.3	SLAVE0_CONFIG (04h)	110
12.4	SLV1_ADD (05h)	111
12.5	SLV1_SUBADD (06h)	111
12.6	SLAVE1_CONFIG (07h)	112

12.7	SLV2_ADD (08h)	112
12.8	SLV2_SUBADD (09h)	112
12.9	SLAVE2_CONFIG (0Ah)	113
12.10	SLV3_ADD (0Bh)	113
12.11	SLV3_SUBADD (0Ch)	113
12.12	SLAVE3_CONFIG (0Dh)	114
12.13	DATAWRITE_SRC_MODE_SUB_SLV0 (0Eh)	114
12.14	CONFIG_PEDO_THS_MIN (0Fh)	114
12.15	SM_THS (13h)	115
12.16	PEDO_DEB_REG (14h)	115
12.17	STEP_COUNT_DELTA (15h)	115
12.18	MAG_SI_XX (24h)	116
12.19	MAG_SI_XY (25h)	116
12.20	MAG_SI_XZ (26h)	116
12.21	MAG_SI_YX (27h)	116
12.22	MAG_SI_YY (28h)	117
12.23	MAG_SI_YZ (29h)	117
12.24	MAG_SI_ZX (2Ah)	117
12.25	MAG_SI_ZY (2Bh)	117
12.26	MAG_SI_ZZ (2Ch)	118
12.27	MAG_OFFX_L (2Dh)	118
12.28	MAG_OFFX_H (2Eh)	118
12.29	MAG_OFFY_L (2Fh)	118
12.30	MAG_OFFY_H (30h)	119
12.31	MAG_OFFZ_L (31h)	119
12.32	MAG_OFFZ_H (32h)	119
13	Embedded functions registers description - Bank B	120
13.1	A_WRIST_TILT_LAT (50h)	120
13.2	A_WRIST_TILT_THS (54h)	120
13.3	A_WRIST_TILT_Mask (59h)	120
14	Soldering information	121

15	Package information	122
	15.1 LGA-14L package information	122
	15.2 LGA-14 packing information	123
16	Revision history	125

List of tables

Table 1.	Device summary	1
Table 2.	Pin description	22
Table 3.	Mechanical characteristics	23
Table 4.	Electrical characteristics	26
Table 5.	Temperature sensor characteristics	27
Table 6.	SPI slave timing values (in mode 3)	28
Table 7.	I ² C slave timing values	29
Table 8.	I ² C master timing values	30
Table 9.	Absolute maximum ratings	31
Table 10.	Serial interface pin description	41
Table 11.	Master I ² C pin details	41
Table 12.	Auxiliary SPI pin details	42
Table 13.	I ² C terminology	42
Table 14.	SAD+Read/Write patterns	43
Table 15.	Transfer when master is writing one byte to slave	43
Table 16.	Transfer when master is writing multiple bytes to slave	43
Table 17.	Transfer when master is receiving (reading) one byte of data from slave	43
Table 18.	Transfer when master is receiving (reading) multiple bytes of data from slave	43
Table 19.	Internal pin status	53
Table 20.	Registers address map	57
Table 21.	FUNC_CFG_ACCESS register	61
Table 22.	FUNC_CFG_ACCESS register description	61
Table 23.	Configuration of embedded functions register banks	61
Table 24.	SENSOR_SYNC_TIME_FRAME register	61
Table 25.	SENSOR_SYNC_TIME_FRAME register description	61
Table 26.	SENSOR_SYNC_RES_RATIO register	62
Table 27.	SENSOR_SYNC_RES_RATIO register description	62
Table 28.	FIFO_CTRL1 register	62
Table 29.	FIFO_CTRL1 register description	62
Table 30.	FIFO_CTRL2 register	63
Table 31.	FIFO_CTRL2 register description	63
Table 32.	FIFO_CTRL3 register	64
Table 33.	FIFO_CTRL3 register description	64
Table 34.	Gyro FIFO decimation setting	64
Table 35.	Accelerometer FIFO decimation setting	64
Table 36.	FIFO_CTRL4 register	65
Table 37.	FIFO_CTRL4 register description	65
Table 38.	Fourth FIFO data set decimation setting	65
Table 39.	Third FIFO data set decimation setting	65
Table 40.	FIFO_CTRL5 register	66
Table 41.	FIFO_CTRL5 register description	66
Table 42.	FIFO ODR selection	66
Table 43.	FIFO mode selection	66
Table 44.	DRDY_PULSE_CFG register	67
Table 45.	DRDY_PULSE_CFG register description	67
Table 46.	INT1_CTRL register	67
Table 47.	INT1_CTRL register description	67
Table 48.	INT2_CTRL register	68

Table 49.	INT2_CTRL register description	68
Table 50.	WHO_AM_I register	68
Table 51.	CTRL1_XL register	69
Table 52.	CTRL1_XL register description	69
Table 53.	Accelerometer ODR register setting	69
Table 54.	CTRL2_G register	70
Table 55.	CTRL2_G register description	70
Table 56.	Gyroscope ODR configuration setting	70
Table 57.	CTRL3_C register	71
Table 58.	CTRL3_C register description	71
Table 59.	CTRL4_C register	72
Table 60.	CTRL4_C register description	72
Table 61.	CTRL5_C register	72
Table 62.	CTRL5_C register description	72
Table 63.	Output registers rounding pattern	73
Table 64.	Angular rate sensor self-test mode selection	73
Table 65.	Linear acceleration sensor self-test mode selection	73
Table 66.	CTRL6_C register	74
Table 67.	CTRL6_C register description	74
Table 68.	Trigger mode selection	74
Table 69.	Gyroscope LPF1 bandwidth selection	74
Table 70.	CTRL7_G register	75
Table 71.	CTRL7_G register description	75
Table 72.	CTRL8_XL register	75
Table 73.	CTRL8_XL register description	75
Table 74.	Accelerometer bandwidth selection	76
Table 75.	CTRL9_XL register	76
Table 76.	CTRL9_XL register description	76
Table 77.	CTRL10_C register	77
Table 78.	CTRL10_C register description	77
Table 79.	MASTER_CONFIG register	77
Table 80.	MASTER_CONFIG register description	78
Table 81.	WAKE_UP_SRC register	78
Table 82.	WAKE_UP_SRC register description	78
Table 83.	TAP_SRC register	79
Table 84.	TAP_SRC register description	79
Table 85.	D6D_SRC register	79
Table 86.	D6D_SRC register description	79
Table 87.	STATUS_REG register	80
Table 88.	STATUS_REG register description	80
Table 89.	STATUS_SPIAux register	80
Table 90.	STATUS_SPIAux description	80
Table 91.	OUT_TEMP_L register	80
Table 92.	OUT_TEMP_H register	80
Table 93.	OUT_TEMP register description	80
Table 94.	OUTX_L_G register	81
Table 95.	OUTX_L_G register description	81
Table 96.	OUTX_H_G register	81
Table 97.	OUTX_H_G register description	81
Table 98.	OUTY_L_G register	82
Table 99.	OUTY_L_G register description	82
Table 100.	OUTY_H_G register	82

Table 101.	OUTY_H_G register description	82
Table 102.	OUTZ_L_G register	83
Table 103.	OUTZ_L_G register description	83
Table 104.	OUTZ_H_G register	83
Table 105.	OUTZ_H_G register description	83
Table 106.	OUTX_L_XL register	84
Table 107.	OUTX_L_XL register description	84
Table 108.	OUTX_H_XL register	84
Table 109.	OUTX_H_XL register description	84
Table 110.	OUTY_L_XL register	84
Table 111.	OUTY_L_XL register description	84
Table 112.	OUTY_H_XL register	85
Table 113.	OUTY_H_XL register description	85
Table 114.	OUTZ_L_XL register	85
Table 115.	OUTZ_L_XL register description	85
Table 116.	OUTZ_H_XL register	85
Table 117.	OUTZ_H_XL register description	85
Table 118.	SENSORHUB1_REG register	85
Table 119.	SENSORHUB1_REG register description	85
Table 120.	SENSORHUB2_REG register	86
Table 121.	SENSORHUB2_REG register description	86
Table 122.	SENSORHUB3_REG register	86
Table 123.	SENSORHUB3_REG register description	86
Table 124.	SENSORHUB4_REG register	86
Table 125.	SENSORHUB4_REG register description	86
Table 126.	SENSORHUB5_REG register	86
Table 127.	SENSORHUB5_REG register description	86
Table 128.	SENSORHUB6_REG register	87
Table 129.	SENSORHUB6_REG register description	87
Table 130.	SENSORHUB7_REG register	87
Table 131.	SENSORHUB7_REG register description	87
Table 132.	SENSORHUB8_REG register	87
Table 133.	SENSORHUB8_REG register description	87
Table 134.	SENSORHUB9_REG register	87
Table 135.	SENSORHUB9_REG register description	87
Table 136.	SENSORHUB10_REG register	88
Table 137.	SENSORHUB10_REG register description	88
Table 138.	SENSORHUB11_REG register	88
Table 139.	SENSORHUB11_REG register description	88
Table 140.	SENSORHUB12_REG register	88
Table 141.	SENSORHUB12_REG register description	88
Table 142.	FIFO_STATUS1 register	88
Table 143.	FIFO_STATUS1 register description	88
Table 144.	FIFO_STATUS2 register	89
Table 145.	FIFO_STATUS2 register description	89
Table 146.	FIFO_STATUS3 register	89
Table 147.	FIFO_STATUS3 register description	89
Table 148.	FIFO_STATUS4 register	90
Table 149.	FIFO_STATUS4 register description	90
Table 150.	FIFO_DATA_OUT_L register	90
Table 151.	FIFO_DATA_OUT_L register description	90
Table 152.	FIFO_DATA_OUT_H register	90

Table 153.	FIFO_DATA_OUT_H register description	90
Table 154.	TIMESTAMP0_REG register	91
Table 155.	TIMESTAMP0_REG register description	91
Table 156.	TIMESTAMP1_REG register	91
Table 157.	TIMESTAMP1_REG register description	91
Table 158.	TIMESTAMP2_REG register	91
Table 159.	TIMESTAMP2_REG register description	91
Table 160.	STEP_TIMESTAMP_L register	91
Table 161.	STEP_TIMESTAMP_L register description	91
Table 162.	STEP_TIMESTAMP_H register	92
Table 163.	STEP_TIMESTAMP_H register description	92
Table 164.	STEP_COUNTER_L register	92
Table 165.	STEP_COUNTER_L register description	92
Table 166.	STEP_COUNTER_H register	92
Table 167.	STEP_COUNTER_H register description	92
Table 168.	SENSORHUB13_REG register	92
Table 169.	SENSORHUB13_REG register description	92
Table 170.	SENSORHUB14_REG register	93
Table 171.	SENSORHUB14_REG register description	93
Table 172.	SENSORHUB15_REG register	93
Table 173.	SENSORHUB15_REG register description	93
Table 174.	SENSORHUB16_REG register	93
Table 175.	SENSORHUB16_REG register description	93
Table 176.	SENSORHUB17_REG register	93
Table 177.	SENSORHUB17_REG register description	93
Table 178.	SENSORHUB18_REG register	94
Table 179.	SENSORHUB18_REG register description	94
Table 180.	FUNC_SRC1 register	94
Table 181.	FUNC_SRC1 register description	94
Table 182.	FUNC_SRC2 register	95
Table 183.	FUNC_SRC2 register description	95
Table 184.	WRIST_TILT_IA register	95
Table 185.	WRIST_TILT_IA register description	95
Table 186.	TAP_CFG register	96
Table 187.	TAP_CFG register description	96
Table 188.	TAP_THS_6D register	97
Table 189.	TAP_THS_6D register description	97
Table 190.	Threshold for D4D/D6D function	97
Table 191.	INT_DUR2 register	97
Table 192.	INT_DUR2 register description	97
Table 193.	WAKE_UP_THS register	98
Table 194.	WAKE_UP_THS register description	98
Table 195.	WAKE_UP_DUR register	98
Table 196.	WAKE_UP_DUR register description	98
Table 197.	FREE_FALL register	99
Table 198.	FREE_FALL register description	99
Table 199.	Threshold for free-fall function	99
Table 200.	MD1_CFG register	100
Table 201.	MD1_CFG register description	100
Table 202.	MD2_CFG register	101
Table 203.	MD2_CFG register description	101
Table 204.	MASTER_CMD_CODE register	102

Table 205.	MASTER_CMD_CODE register description	102
Table 206.	SENS_SYNC_SPI_ERROR_CODE register	102
Table 207.	SENS_SYNC_SPI_ERROR_CODE register description	102
Table 208.	OUT_MAG_RAW_X_L register	102
Table 209.	OUT_MAG_RAW_X_L register description	102
Table 210.	OUT_MAG_RAW_X_H register	102
Table 211.	OUT_MAG_RAW_X_H register description	102
Table 212.	OUT_MAG_RAW_Y_L register	103
Table 213.	OUT_MAG_RAW_Y_L register description	103
Table 214.	OUT_MAG_RAW_Y_H register	103
Table 215.	OUT_MAG_RAW_Y_H register description	103
Table 216.	OUT_MAG_RAW_Z_L register	103
Table 217.	OUT_MAG_RAW_Z_L register description	103
Table 218.	OUT_MAG_RAW_Z_H register	103
Table 219.	OUT_MAG_RAW_Z_H register description	103
Table 220.	INT_OIS register	104
Table 221.	INT_OIS register description	104
Table 222.	CTRL1_OIS register	104
Table 223.	CTRL1_OIS register description	104
Table 224.	DEN mode selection	105
Table 225.	CTRL2_OIS register	105
Table 226.	CTRL2_OIS register description	105
Table 227.	Gyroscope OIS chain LPF1 bandwidth selection	105
Table 228.	CTRL3_OIS register	106
Table 229.	CTRL3_OIS register description	106
Table 230.	Accelerometer OIS channel bandwidth selection	106
Table 231.	Self-test nominal output variation	107
Table 232.	X_OFS_USR register	107
Table 233.	X_OFS_USR register description	107
Table 234.	Y_OFS_USR register	107
Table 235.	Y_OFS_USR register description	107
Table 236.	Z_OFS_USR register	107
Table 237.	Z_OFS_USR register description	107
Table 238.	Register address map - Bank A - embedded functions	108
Table 239.	Register address map - Bank B - embedded functions	109
Table 240.	SLV0_ADD register	110
Table 241.	SLV0_ADD register description	110
Table 242.	SLV0_SUBADD register	110
Table 243.	SLV0_SUBADD register description	110
Table 244.	SLAVE0_CONFIG register	110
Table 245.	SLAVE0_CONFIG register description	111
Table 246.	SLV1_ADD register	111
Table 247.	SLV1_ADD register description	111
Table 248.	SLV1_SUBADD register	111
Table 249.	SLV1_SUBADD register description	111
Table 250.	SLAVE1_CONFIG register	112
Table 251.	SLAVE1_CONFIG register description	112
Table 252.	SLV2_ADD register	112
Table 253.	SLV2_ADD register description	112
Table 254.	SLV2_SUBADD register	112
Table 255.	SLV2_SUBADD register description	112
Table 256.	SLAVE2_CONFIG register	113

Table 257.	SLAVE2_CONFIG register description	113
Table 258.	SLV3_ADD register	113
Table 259.	SLV3_ADD register description	113
Table 260.	SLV3_SUBADD register	113
Table 261.	SLV3_SUBADD register description	113
Table 262.	SLAVE3_CONFIG register	114
Table 263.	SLAVE3_CONFIG register description	114
Table 264.	DATAWRITE_SRC_MODE_SUB_SLV0 register	114
Table 265.	DATAWRITE_SRC_MODE_SUB_SLV0 register description	114
Table 266.	CONFIG_PEDO_THS_MIN register	114
Table 267.	CONFIG_PEDO_THS_MIN register description	114
Table 268.	SM_THS register	115
Table 269.	SM_THS register description	115
Table 270.	PEDO_DEB_REG register	115
Table 271.	PEDO_DEB_REG register description	115
Table 272.	STEP_COUNT_DELTA register	115
Table 273.	STEP_COUNT_DELTA register description	115
Table 274.	MAG_SI_XX register	116
Table 275.	MAG_SI_XX register description	116
Table 276.	MAG_SI_XY register	116
Table 277.	MAG_SI_XY register description	116
Table 278.	MAG_SI_XZ register	116
Table 279.	MAG_SI_XZ register description	116
Table 280.	MAG_SI_YX register	116
Table 281.	MAG_SI_YX register description	116
Table 282.	MAG_SI_YY register	117
Table 283.	MAG_SI_YY register description	117
Table 284.	MAG_SI_YZ register	117
Table 285.	MAG_SI_YZ register description	117
Table 286.	MAG_SI_ZX register	117
Table 287.	MAG_SI_ZX register description	117
Table 288.	MAG_SI_ZY register	117
Table 289.	MAG_SI_ZY register description	117
Table 290.	MAG_SI_ZZ register	118
Table 291.	MAG_SI_ZZ register description	118
Table 292.	MAG_OFFX_L register	118
Table 293.	MAG_OFFX_L register description	118
Table 294.	MAG_OFFX_H register	118
Table 295.	MAG_OFFX_H register description	118
Table 296.	MAG_OFFY_L register	118
Table 297.	MAG_OFFY_L register description	118
Table 298.	MAG_OFFY_H register	119
Table 299.	MAG_OFFY_H register description	119
Table 300.	MAG_OFFZ_L register	119
Table 301.	MAG_OFFZ_L register description	119
Table 302.	MAG_OFFZ_H register	119
Table 303.	MAG_OFFZ_H register description	119
Table 304.	A_WRIST_TILT_LAT register	120
Table 305.	A_WRIST_TILT_LAT register description	120
Table 306.	A_WRIST_TILT_THS register	120
Table 307.	A_WRIST_TILT_THS register description	120
Table 308.	A_WRIST_TILT_Mask register	120

Table 309. A_WRIST_TILT_Mask register description.	120
Table 310. Reel dimensions for carrier tape of LGA-14 package	124
Table 311. Document revision history.	125

List of figures

Figure 1.	Pin connections	20
Figure 2.	LSM6DSM connection modes	21
Figure 3.	SPI slave timing diagram (in mode 3)	28
Figure 4.	I ² C timing diagram	29
Figure 5.	Block diagram of filters	34
Figure 6.	Gyroscope digital chain - Mode 1 (UI/EIS) and Mode 2	34
Figure 7.	Gyroscope digital chain - Mode 3 / Mode 4 (OIS/EIS)	35
Figure 8.	Accelerometer chain	36
Figure 9.	Accelerometer composite filter (for Modes 1/2 and Mode 3*)	36
Figure 10.	Accelerometer composite filter (Mode 4 only*)	37
Figure 11.	Read and write protocol (in mode 3)	45
Figure 12.	SPI read protocol (in mode 3)	46
Figure 13.	Multiple byte SPI read protocol (2-byte example) (in mode 3)	46
Figure 14.	SPI write protocol (in mode 3)	47
Figure 15.	Multiple byte SPI write protocol (2-byte example) (in mode 3)	47
Figure 16.	SPI read protocol in 3-wire mode (in mode 3)	48
Figure 17.	LSM6DSM electrical connections in Mode 1	49
Figure 18.	LSM6DSM electrical connections in Mode 2	50
Figure 19.	LSM6DSM electrical connections in Mode 3 and Mode 4 (auxiliary 3-wire SPI)	51
Figure 20.	LSM6DSM electrical connections in Mode 3 and Mode 4 (auxiliary 4-wire SPI)	52
Figure 21.	Gyroscope chain	55
Figure 22.	Accelerometer chain (available only in Mode 4)	56
Figure 23.	LGA-14L 2.5x3x0.86 mm package outline and mechanical data	122
Figure 24.	Carrier tape information for LGA-14 package	123
Figure 25.	LGA-14 package orientation in carrier tape	123
Figure 26.	Reel information for carrier tape of LGA-14 package	124

1 Overview

The LSM6DSM is a system-in-package featuring a high-performance 3-axis digital accelerometer and 3-axis digital gyroscope.

The integrated power-efficient modes are able to reduce the power consumption down to 0.65 mA in high-performance mode, combining always-on low-power features with superior sensing precision for an optimal motion experience for the consumer thanks to ultra-low noise performance for both the gyroscope and accelerometer.

The LSM6DSM delivers best-in-class motion sensing that can detect orientation and gestures in order to empower application developers and consumers with features and capabilities that are more sophisticated than simply orienting their devices to portrait and landscape mode.

The event-detection interrupts enable efficient and reliable motion tracking and contextual awareness, implementing hardware recognition of free-fall events, 6D orientation, click and double-click sensing, activity or inactivity, and wakeup events.

The LSM6DSM supports main OS requirements, offering real, virtual and batch mode sensors. In addition, the LSM6DSM can efficiently run the sensor-related features specified in Android, saving power and enabling faster reaction time. In particular, the LSM6DSM has been designed to implement hardware features such as significant motion, tilt, pedometer functions, timestamping and to support the data acquisition of an external magnetometer with ironing correction (hard, soft).

The LSM6DSM offers hardware flexibility to connect the pins with different mode connections to external sensors to expand functionalities such as adding a sensor hub, auxiliary SPI, etc.

Up to 4 kbyte of FIFO with dynamic allocation of significant data (i.e. external sensors, timestamp, etc.) allows overall power saving of the system.

The LSM6DSM fully supports OIS/EIS applications using both the gyroscope and accelerometer sensor. The device can output OIS data through a dedicated auxiliary SPI and includes a dedicated configurable signal processing path for OIS. OIS data can be sent directly to the application processor for data processing. The gyroscope UI signal processing path is completely independent from that of the OIS and is readable through FIFO.

Like the entire portfolio of MEMS sensor modules, the LSM6DSM leverages the robust and mature in-house manufacturing processes already used for the production of micromachined accelerometers and gyroscopes. The various sensing elements are manufactured using specialized micromachining processes, while the IC interfaces are developed using CMOS technology that allows the design of a dedicated circuit which is trimmed to better match the characteristics of the sensing element.

The LSM6DSM is available in a small plastic land grid array (LGA) package of 2.5 x 3.0 x 0.83 mm to address ultra-compact solutions.

2 Embedded low-power features

The LSM6DSM has been designed to be fully compliant with Android, featuring the following on-chip functions:

- 4 kbyte data buffering
 - 100% efficiency with flexible configurations and partitioning
 - Possibility to store timestamp
- Event-detection interrupts (fully configurable):
 - Free-fall
 - Wakeup
 - 6D orientation
 - Click And double-click sensing
 - Activity / inactivity recognition
- Specific IP blocks with negligible power consumption and high-performance:
 - Pedometer functions: step detector and step counters
 - Tilt (refer to [Section 2.1: Tilt detection](#) for additional information)
 - Absolute Wrist Tilt (refer to [Section 2.2: Absolute wrist tilt](#) for additional information)
 - Significant Motion Detection
- Sensor hub
 - Up to 6 total sensors: 2 internal (accelerometer and gyroscope) and 4 external sensors
- Data rate synchronization with external trigger for reduced sensor access and enhanced fusion

2.1 Tilt detection

The tilt function helps to detect activity change and has been implemented in hardware using only the accelerometer to achieve both the targets of ultra-low power consumption and robustness during the short duration of dynamic accelerations.

It is based on a trigger of an event each time the device's tilt changes. For a more customized user experience, in the LSM6DSM the tilt function is configurable through:

- a programmable average window
- a programmable average threshold

The tilt function can be used with different scenarios, for example:

- a) Triggers when phone is in a front pants pocket and the user goes from sitting to standing or standing to sitting;
- b) Doesn't trigger when phone is in a front pants pocket and the user is walking, running or going upstairs.

2.2 Absolute wrist tilt

The LSM6DSM implements in hardware the Absolute Wrist Tilt (AWT) function which allows detecting when the angle between a selectable accelerometer semi-axis and the horizontal plane becomes higher than a specific user-selectable value.

Configurable threshold and latency parameters are associated with the AWT function: the threshold parameter defines the amplitude of the tilt angle; the latency parameter defines the minimum duration of the AWT event to be recognized. The AWT interrupt signal is generated if the tilt angle is higher than the threshold angle for a period of time equal to or greater than the latency period.

The AWT function is based on the accelerometer sensor only and works at 26 Hz, so the accelerometer ODR must be set at a value of 26 Hz or higher.

By default, the AWT algorithm is applied to the positive X-axis.

In order to enable the AWT function it is necessary to set to 1 both the FUNC_EN bit and the WRIST_TILT_EN bit of *CTRL10_C (19h)*.

The AWT interrupt signal can be driven to the INT2 interrupt pin by setting to 1 the INT2_WRIST_TILT bit of the *DRDY_PULSE_CFG (0Bh)* register; it can also be checked by reading the WRIST_TILT_IA bit of the *FUNC_SRC2 (54h)* register (it will also clear the interrupt signal if latched).

WRIST_TILT_IA (55h) is the status register to be used to detect which axis has triggered the AWT event (not applicable when using one axis side only).

The full description and an example is given in the dedicated application note.

3 Pin description

Figure 1. Pin connections

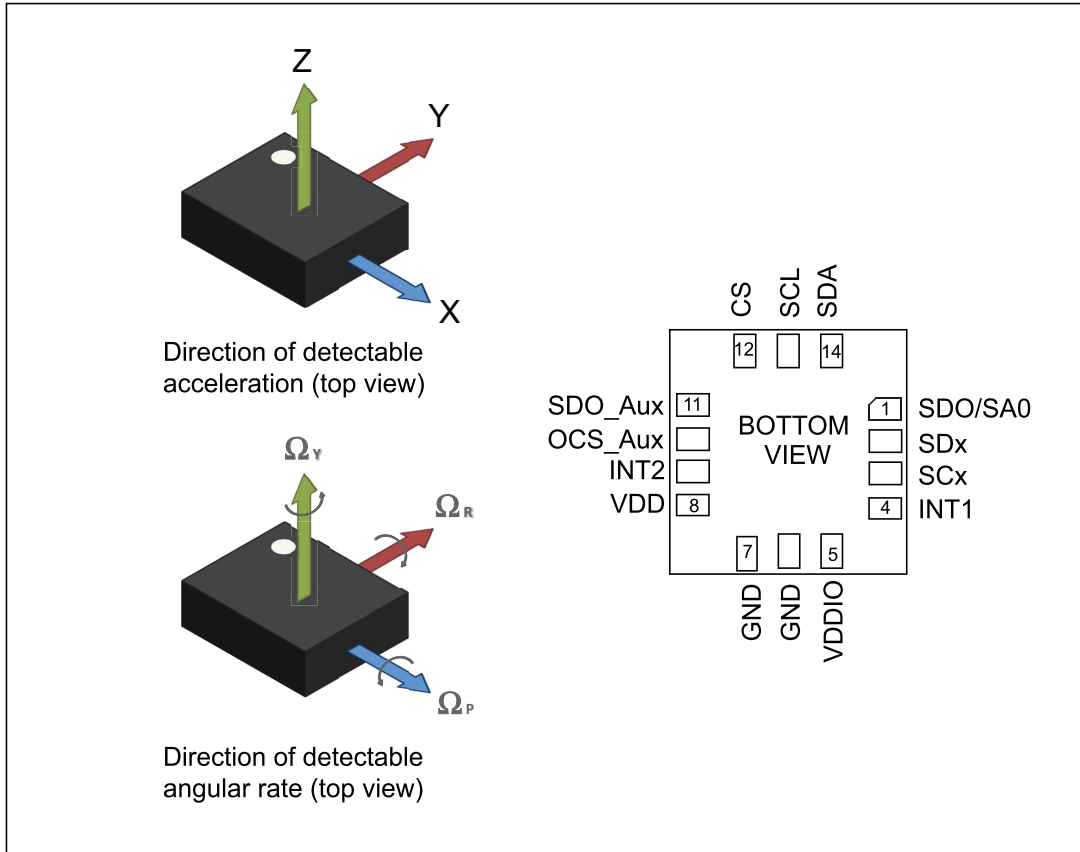

3.1 Pin connections

The LSM6DSM offers flexibility to connect the pins in order to have four different mode connections and functionalities. In detail:

- **Mode 1:** I²C slave interface or SPI (3- and 4-wire) serial interface is available;
- **Mode 2:** I²C slave interface or SPI (3- and 4-wire) serial interface and I²C interface master for external sensor connections are available;
- **Mode 3:** I²C slave interface or SPI (3- and 4-wire) serial interface is available for the application processor interface while an auxiliary SPI (3- and 4-wire) serial interface for external sensor connections (i.e. camera module) is available for the gyroscope ONLY;
- **Mode 4:** I²C slave interface or SPI (3- and 4-wire) serial interface is available for the application processor interface while an auxiliary SPI (3- and 4-wire) serial interface for external sensor connections (i.e. camera module with hybrid OIS) is available for the accelerometer and gyroscope.

Figure 2. LSM6DSM connection modes

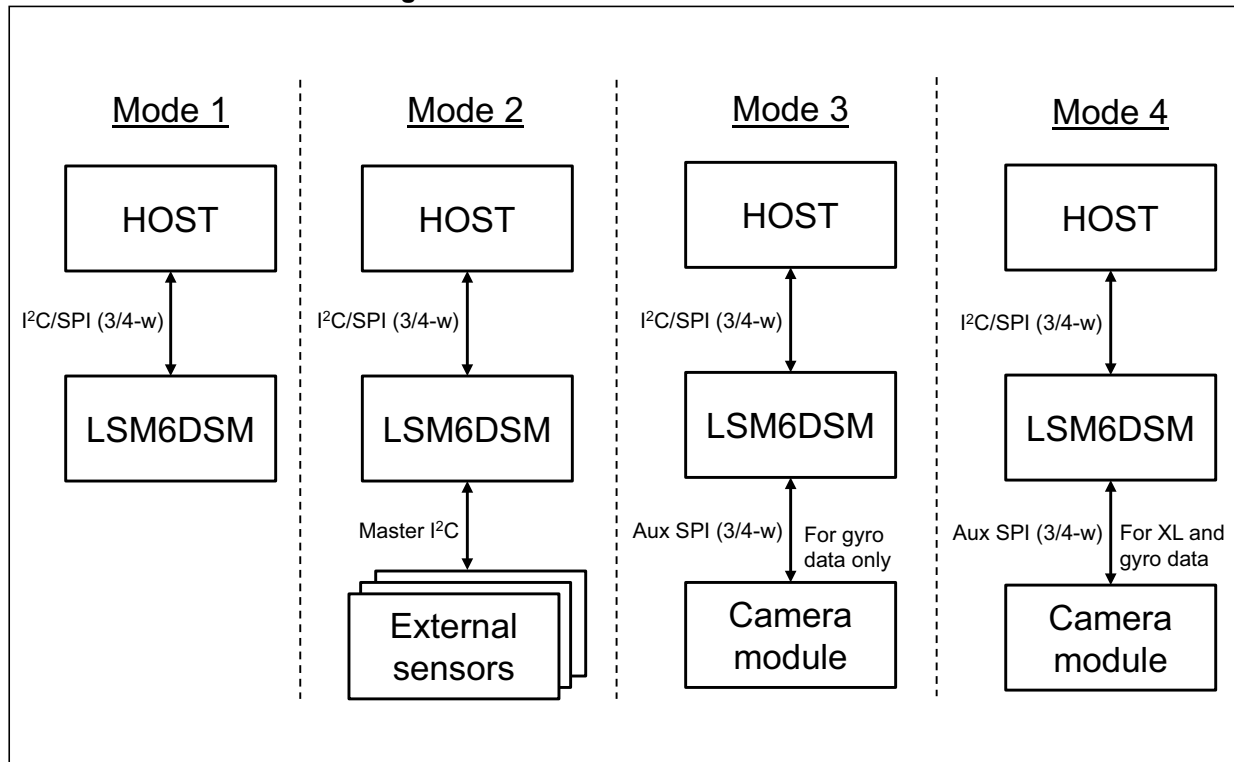

In the following table each mode is described for the pin connections and function.

Table 2. Pin description

Pin#	Name	Mode 1 function	Mode 2 function	Mode 3 / Mode 4 function
1	SDO/SA0	SPI 4-wire interface serial data output (SDO) I ² C least significant bit of the device address (SA0)	SPI 4-wire interface serial data output (SDO) I ² C least significant bit of the device address (SA0)	SPI 4-wire interface serial data output (SDO) I ² C least significant bit of the device address (SA0)
2	SDx	Connect to VDDIO or GND	I ² C serial data master (MSDA)	Auxiliary SPI 3/4-wire interface serial data input (SDI) and SPI 3-wire serial data output (SDO)
3	SCx	Connect to VDDIO or GND	I ² C serial clock master (MSCL)	Auxiliary SPI 3-wire interface serial port clock (SPC_Aux)
4	INT1	Programmable interrupt 1		
5	VDDIO ⁽¹⁾	Power supply for I/O pins		
6	GND	0 V supply		
7	GND	0 V supply		
8	VDD ⁽¹⁾	Power supply		
9	INT2	Programmable interrupt 2 (INT2) / Data enable (DEN)	Programmable interrupt 2 (INT2)/ Data enable (DEN)/ I ² C master external synchronization signal (MDRDY)	Programmable interrupt 2 (INT2)/ Data enable (DEN)
10	OCS_Aux	Leave unconnected ⁽²⁾	Leave unconnected ⁽²⁾	Auxiliary SPI 3/4-wire interface enable
11	SDO_Aux	Connect to VDDIO or leave unconnected ⁽²⁾	Connect to VDDIO or leave unconnected ⁽²⁾	Auxiliary SPI 3-wire interface: leave unconnected ⁽²⁾ Auxiliary SPI 4-wire interface: serial data output (SDO_Aux)
12	CS	I ² C/SPI mode selection (1: SPI idle mode / I ² C communication enabled; 0: SPI communication mode / I ² C disabled)	I ² C/SPI mode selection (1: SPI idle mode / I ² C communication enabled; 0: SPI communication mode / I ² C disabled)	I ² C/SPI mode selection (1: SPI idle mode / I ² C communication enabled; 0: SPI communication mode / I ² C disabled)
13	SCL	I ² C serial clock (SCL) SPI serial port clock (SPC)	I ² C serial clock (SCL) SPI serial port clock (SPC)	I ² C serial clock (SCL) SPI serial port clock (SPC)
14	SDA	I ² C serial data (SDA) SPI serial data input (SDI) 3-wire interface serial data output (SDO)	I ² C serial data (SDA) SPI serial data input (SDI) 3-wire interface serial data output (SDO)	I ² C serial data (SDA) SPI serial data input (SDI) 3-wire interface serial data output (SDO)

1. Recommended 100 nF filter capacitor.

2. Leave pin electrically unconnected and soldered to PCB.

4 Module specifications

4.1 Mechanical characteristics

@ Vdd = 1.8 V, T = 25 °C unless otherwise noted.

Table 3. Mechanical characteristics

Symbol	Parameter	Test conditions	Min.	Typ. ⁽¹⁾	Max.	Unit
LA_FS	Linear acceleration measurement range			±2		g
				±4		
				±8		
				±16		
G_FS	Angular rate measurement range			±125		dps
				±250		
				±500		
				±1000		
LA_So	Linear acceleration sensitivity ⁽²⁾	FS = ±2		0.061		mg/LSB
		FS = ±4		0.122		
		FS = ±8		0.244		
		FS = ±16		0.488		
G_So	Angular rate sensitivity ⁽²⁾	FS = ±125		4.375		mdps/LSB
		FS = ±250		8.75		
		FS = ±500		17.50		
		FS = ±1000		35		
		FS = ±2000		70		
G_So%	Sensitivity tolerance ⁽³⁾	at component level		±1		%
LA_SoDr	Linear acceleration sensitivity change vs. temperature ⁽⁴⁾	from -40° to +85°		±0.01		%/°C
G_SoDr	Angular rate sensitivity change vs. temperature ⁽⁴⁾	from -40° to +85°		±0.007		%/°C
LA_TyOff	Linear acceleration zero-g level offset accuracy ⁽⁵⁾			±40		mg
G_TyOff	Angular rate zero-rate level ⁽⁵⁾			±2		dps
LA_OffDr	Linear acceleration zero-g level change vs. temperature ⁽⁴⁾			±0.1		mg/°C
G_OffDr	Angular rate typical zero-rate level change vs. temperature ⁽⁴⁾			±0.015		dps/°C

Table 3. Mechanical characteristics (continued)

Symbol	Parameter	Test conditions	Min.	Typ. ⁽¹⁾	Max.	Unit
Rn	Rate noise density in high-performance mode ⁽⁶⁾			3.8		mdps/ $\sqrt{\text{Hz}}$
RnRMS	Gyroscope RMS noise in normal/low-power mode ⁽⁷⁾			75		mdps
An	Acceleration noise density in high-performance mode ⁽⁸⁾	FS = $\pm 2\text{ g}$		75		$\mu\text{g}/\sqrt{\text{Hz}}$
		FS = $\pm 4\text{ g}$		80		
		FS = $\pm 8\text{ g}$		90		
		FS = $\pm 16\text{ g}$		130		
RMS	Acceleration RMS noise in normal/low-power mode ⁽⁹⁾⁽¹⁰⁾	FS = $\pm 2\text{ g}$		1.8		mg(RMS)
		FS = $\pm 4\text{ g}$		2.0		
		FS = $\pm 8\text{ g}$		2.4		
		FS = $\pm 16\text{ g}$		3.0		
LA_ODR	Linear acceleration output data rate			1.6 ⁽¹¹⁾		Hz
				12.5		
				26		
				52		
				104		
				208		
				416		
				833		
				1666		
G_ODR	Angular rate output data rate			12.5		Hz
				26		
				52		
				104		
				208		
				416		
				833		
				1666		
				3332		
Vst	Linear acceleration self-test output change ⁽¹²⁾⁽¹³⁾⁽¹⁴⁾		90		1700	mg
	Angular rate self-test output change ⁽¹⁵⁾⁽¹⁶⁾	FS = 250 dps	20		80	dps
		FS = 2000 dps	150		700	dps
Top	Operating temperature range		-40		+85	$^{\circ}\text{C}$

1. Typical specifications are not guaranteed.
2. Sensitivity values after factory calibration test and trimming.
3. Subject to change.



4. Measurements are performed in a uniform temperature setup and they are based on characterization data in a limited number of samples. Not measured during final test for production.
5. Values after factory calibration test and trimming.
6. Gyroscope rate noise density in high-performance mode is independent of the ODR and FS setting.
7. Gyroscope RMS noise in normal/low-power mode is independent of the ODR and FS setting.
8. Accelerometer noise density in high-performance mode is independent of the ODR.
9. Accelerometer RMS noise in normal/low-power mode is independent of the ODR.
10. Noise RMS related to $BW = ODR / 2$ (for $ODR / 9$, typ value can be calculated by $Typ * 0.6$).
11. This ODR is available when accelerometer is in low-power mode.
12. The sign of the linear acceleration self-test output change is defined by the STx_XL bits in [CTRL5_C \(14h\)](#), [Table 65](#) for all axes.
13. The linear acceleration self-test output change is defined with the device in stationary condition as the absolute value of: $OUTPUT[LSb] \text{ (self-test enabled)} - OUTPUT[LSb] \text{ (self-test disabled)}$. $1LSb = 0.061 \text{ mg}$ at $\pm 2 \text{ g}$ full scale.
14. Accelerometer self-test limits are full-scale independent.
15. The sign of the angular rate self-test output change is defined by the STx_G bits in [CTRL5_C \(14h\)](#), [Table 64](#) for all axes.
16. The angular rate self-test output change is defined with the device in stationary condition as the absolute value of: $OUTPUT[LSb] \text{ (self-test enabled)} - OUTPUT[LSb] \text{ (self-test disabled)}$. $1LSb = 70 \text{ mdps}$ at $\pm 2000 \text{ dps}$ full scale.

4.2 Electrical characteristics

@ V_{dd} = 1.8 V, T = 25 °C unless otherwise noted.

Table 4. Electrical characteristics

Symbol	Parameter	Test conditions	Min.	Typ. ⁽¹⁾	Max.	Unit
V _{dd}	Supply voltage		1.71	1.8	3.6	V
V _{dd_IO}	Power supply for I/O		1.62		3.6	V
I _{ddHP}	Gyroscope and accelerometer current consumption in high-performance mode	ODR = 1.6 kHz		0.65		mA
I _{ddNM}	Gyroscope and accelerometer current consumption in normal mode	ODR = 208 Hz		0.45		mA
I _{ddLP}	Gyroscope and accelerometer current consumption in low-power mode	ODR = 52 Hz		0.29		mA
LA_I _{ddHP}	Accelerometer current consumption in high-performance mode	ODR < 1.6 kHz ODR ≥ 1.6 kHz		150 160		μA
LA_I _{ddNM}	Accelerometer current consumption in normal mode	ODR = 208 Hz		85		μA
LA_I _{ddLM}	Accelerometer current consumption in low-power mode	ODR = 52 Hz ODR = 12.5 Hz ODR = 1.6 Hz		25 9 4.5		μA
I _{ddPD}	Gyroscope and accelerometer current consumption during power-down			3		μA
T _{on}	Turn-on time			35		ms
V _{IH}	Digital high-level input voltage		0.7 *V _{DD_IO}			V
V _{IL}	Digital low-level input voltage				0.3 *V _{DD_IO}	V
V _{OH}	High-level output voltage	I _{OH} = 4 mA ⁽²⁾	V _{DD_IO} - 0.2			V
V _{OL}	Low-level output voltage	I _{OL} = 4 mA ⁽²⁾			0.2	V
T _{op}	Operating temperature range		-40		+85	°C

1. Typical specifications are not guaranteed.
2. 4 mA is the maximum driving capability, i.e. the maximum DC current that can be sourced/sunk by the digital pad in order to guarantee the correct digital output voltage levels V_{OH} and V_{OL}.

4.3 Temperature sensor characteristics

@ Vdd = 1.8 V, T = 25 °C unless otherwise noted.

Table 5. Temperature sensor characteristics

Symbol	Parameter	Test condition	Min.	Typ. ⁽¹⁾	Max.	Unit
TODR ⁽²⁾	Temperature refresh rate			52		Hz
Toff	Temperature offset ⁽³⁾		-15		+15	°C
TSen	Temperature sensitivity			256		LSB/°C
TST	Temperature stabilization time ⁽⁴⁾				500	µs
T_ADC_res	Temperature ADC resolution			16		bit
Top	Operating temperature range		-40		+85	°C

1. Typical specifications are not guaranteed.
2. When the accelerometer is in Low-Power mode and the gyroscope part is turned off, the TODR value is equal to the accelerometer ODR.
3. The output of the temperature sensor is 0 LSB (typ.) at 25 °C.
4. Time from power ON bit to valid data based on characterization data.

4.4 Communication interface characteristics

4.4.1 SPI - serial peripheral interface

Subject to general operating conditions for Vdd and Top.

Table 6. SPI slave timing values (in mode 3)

Symbol	Parameter	Value ⁽¹⁾		Unit
		Min	Max	
$t_{c(SPC)}$	SPI clock cycle	100		ns
$f_{c(SPC)}$	SPI clock frequency		10	MHz
$t_{su(CS)}$	CS setup time	5		ns
$t_{h(CS)}$	CS hold time	20		
$t_{su(SI)}$	SDI input setup time	5		
$t_{h(SI)}$	SDI input hold time	15		
$t_{v(SO)}$	SDO valid output time		50	
$t_{h(SO)}$	SDO output hold time	5		
$t_{dis(SO)}$	SDO output disable time		50	

1. Values are guaranteed at 10 MHz clock frequency for SPI with both 4 and 3 wires, based on characterization results, not tested in production

Figure 3. SPI slave timing diagram (in mode 3)

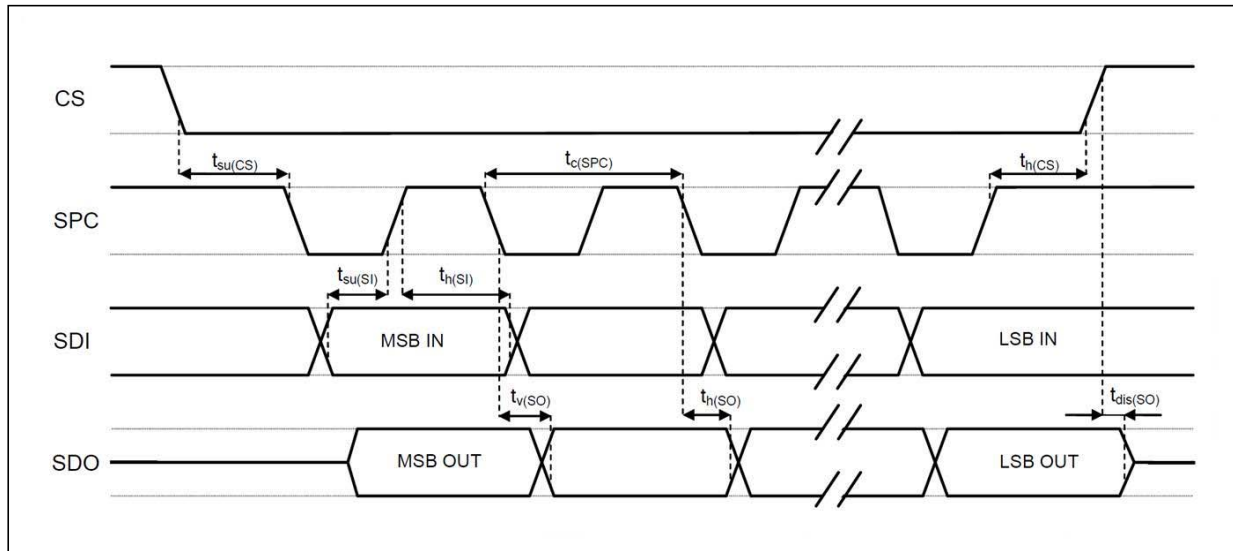

Note: Measurement points are done at $0.2 \cdot V_{dd_IO}$ and $0.8 \cdot V_{dd_IO}$, for both input and output ports.

4.4.2 I²C - inter-IC control interface

Subject to general operating conditions for Vdd and Top.

Figure 4. I²C timing diagram

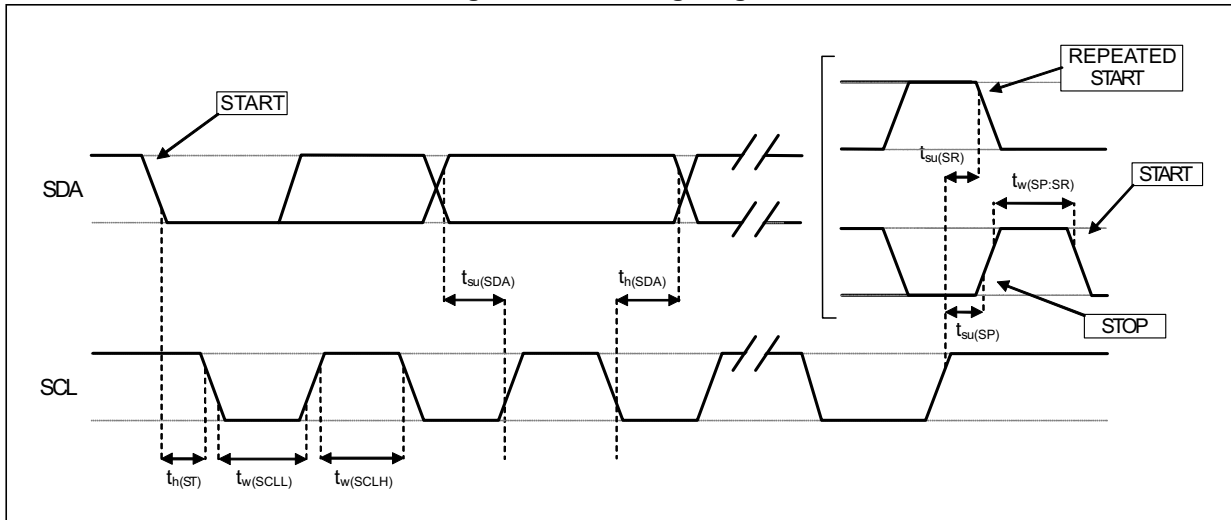

4.4.2.1 I²C slave

Table 7. I²C slave timing values

Symbol	Parameter	I ² C standard mode ⁽¹⁾		I ² C fast mode ⁽¹⁾		Unit
		Min	Max	Min	Max	
f _(SCL)	SCL clock frequency	0	100	0	400	kHz
t _{w(SCLL)}	SCL clock low time	4.7		1.3		
t _{w(SCLH)}	SCL clock high time	4.0		0.6		μs
t _{su(SDA)}	SDA setup time	250		100		
t _{h(SDA)}	SDA data hold time	0	3.45	0	0.9	μs
t _{h(ST)}	START condition hold time	4		0.6		
t _{su(SR)}	Repeated START condition setup time	4.7		0.6		μs
t _{su(SP)}	STOP condition setup time	4		0.6		
t _{w(SP:SR)}	Bus free time between STOP and START condition	4.7		1.3		

1. Data based on standard I²C protocol requirement, not tested in production.

Note: Measurement points are done at 0.2·Vdd_{IO} and 0.8·Vdd_{IO}, for both ports.

4.4.2.2 I²C master

When in I²C Master Mode, an external sensor can be connected to LSM6DSM. LSM6DSM supports I²C Master - Fast Mode only.

Table 8. I²C master timing values

Symbol	Parameter	I ² C Master	I ² C Fast Mode (min)	Unit
f _(SCL)	SCL clock frequency	116.3	0 (400 kHz max)	kHz
t _{w(SCLL)}	SCL clock low time	5.86	1.3	μs
t _{w(SCLH)}	SCL clock high time	2.74	0.6	ns
	Data valid time	3.9	-	μs
	SDA hold time	≥0	0	ns
	SDA setup time	≥100	100	ns
t _{su(SR)}	Repeated START condition setup time	1.56	0.6	μs
t _{su(HD)}	Repeated START condition hold time	1.56	0.6	μs
t _{su(SP)}	STOP condition setup time	2.73	0.6	μs
t _{w(SP:SR)}	Bus free time between STOP and START condition	21	1.3	μs

4.5 Absolute maximum ratings

Stresses above those listed as “Absolute maximum ratings” may cause permanent damage to the device. This is a stress rating only and functional operation of the device under these conditions is not implied. Exposure to maximum rating conditions for extended periods may affect device reliability.

Table 9. Absolute maximum ratings

Symbol	Ratings	Maximum value	Unit
Vdd	Supply voltage	-0.3 to 4.8	V
T _{STG}	Storage temperature range	-40 to +125	°C
Sg	Acceleration g for 0.2 ms	10,000	g
ESD	Electrostatic discharge protection (HBM)	2	kV
V _{in}	Input voltage on any control pin (including CS, SCL/SPC, SDA/SDI/SDO, SDO/SA0)	-0.3 to Vdd_IO +0.3	V

Note: Supply voltage on any pin should never exceed 4.8 V.



This device is sensitive to mechanical shock, improper handling can cause permanent damage to the part.



This device is sensitive to electrostatic discharge (ESD), improper handling can cause permanent damage to the part.

4.6 Terminology

4.6.1 Sensitivity

Linear acceleration sensitivity can be determined, for example, by applying 1 *g* acceleration to the device. Because the sensor can measure DC accelerations, this can be done easily by pointing the selected axis towards the ground, noting the output value, rotating the sensor 180 degrees (pointing towards the sky) and noting the output value again. By doing so, ± 1 *g* acceleration is applied to the sensor. Subtracting the larger output value from the smaller one, and dividing the result by 2, leads to the actual sensitivity of the sensor. This value changes very little over temperature and over time. The sensitivity tolerance describes the range of sensitivities of a large number of sensors (see [Table 3](#)).

An angular rate gyroscope is a device that produces a positive-going digital output for counterclockwise rotation around the axis considered. Sensitivity describes the gain of the sensor and can be determined by applying a defined angular velocity to it. This value changes very little over temperature and time (see [Table 3](#)).

4.6.2 Zero-g and zero-rate level

Linear acceleration zero-*g* level offset (TyOff) describes the deviation of an actual output signal from the ideal output signal if no acceleration is present. A sensor in a steady state on a horizontal surface will measure 0 *g* on both the X-axis and Y-axis, whereas the Z-axis will measure 1 *g*. Ideally, the output is in the middle of the dynamic range of the sensor (content of OUT registers 00h, data expressed as 2's complement number). A deviation from the ideal value in this case is called zero-*g* offset.

Offset is to some extent a result of stress to MEMS sensor and therefore the offset can slightly change after mounting the sensor onto a printed circuit board or exposing it to extensive mechanical stress. Offset changes little over temperature, see "Linear acceleration zero-*g* level change vs. temperature" in [Table 3](#). The zero-*g* level tolerance (TyOff) describes the standard deviation of the range of zero-*g* levels of a group of sensors.

Zero-rate level describes the actual output signal if there is no angular rate present. The zero-rate level of precise MEMS sensors is, to some extent, a result of stress to the sensor and therefore the zero-rate level can slightly change after mounting the sensor onto a printed circuit board or after exposing it to extensive mechanical stress. This value changes very little over temperature and time (see [Table 3](#)).

5 Functionality

5.1 Operating modes

In the LSM6DSM, the accelerometer and the gyroscope can be turned on/off independently of each other and are allowed to have different ODRs and power modes.

The LSM6DSM has three operating modes available:

- only accelerometer active and gyroscope in power-down
- only gyroscope active and accelerometer in power-down
- both accelerometer and gyroscope sensors active with independent ODR

The accelerometer is activated from power-down by writing ODR_XL[3:0] in [CTRL1_XL \(10h\)](#) while the gyroscope is activated from power-down by writing ODR_G[3:0] in [CTRL2_G \(11h\)](#). For combo-mode the ODRs are totally independent.

5.2 Gyroscope power modes

In the LSM6DSM, the gyroscope can be configured in four different operating modes: power-down, low-power, normal mode and high-performance mode. The operating mode selected depends on the value of the G_HM_MODE bit in [CTRL7_G \(16h\)](#). If G_HM_MODE is set to '0', high-performance mode is valid for all ODRs (from 12.5 Hz up to 6.66 kHz).

To enable the low-power and normal mode, the G_HM_MODE bit has to be set to '1'. Low-power mode is available for lower ODRs (12.5, 26, 52 Hz) while normal mode is available for ODRs equal to 104 and 208 Hz.

5.3 Accelerometer power modes

In the LSM6DSM, the accelerometer can be configured in four different operating modes: power-down, low-power, normal mode and high-performance mode. The operating mode selected depends on the value of the XL_HM_MODE bit in [CTRL6_C \(15h\)](#). If XL_HM_MODE is set to '0', high-performance mode is valid for all ODRs (from 12.5 Hz up to 6.66 kHz).

To enable the low-power and normal mode, the XL_HM_MODE bit has to be set to '1'. Low-power mode is available for lower ODRs (1.6, 12.5, 26, 52 Hz) while normal mode is available for ODRs equal to 104 and 208 Hz.

5.4 Block diagram of filters

Figure 5. Block diagram of filters

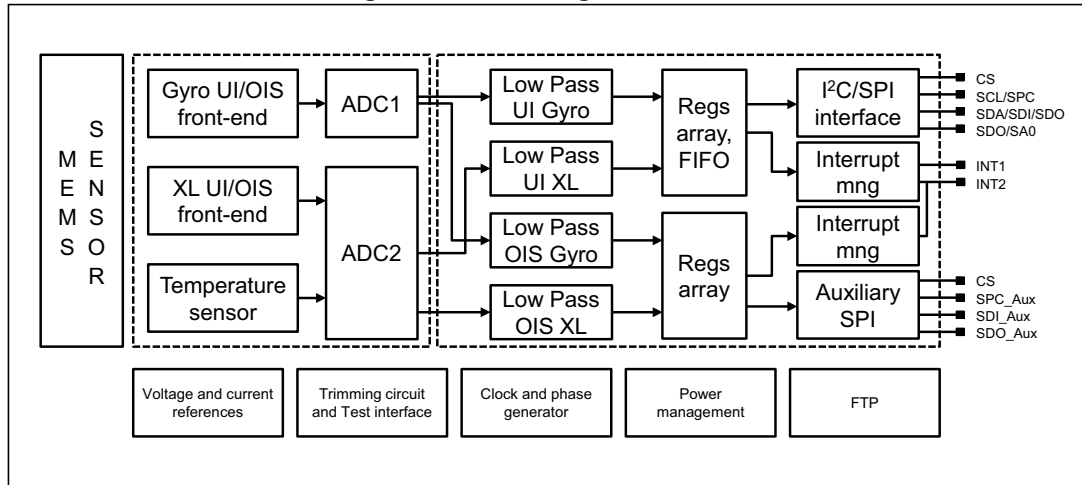

5.4.1 Block diagrams of the gyroscope filters

In the LSM6DSM, the gyroscope filtering chain depends on the mode configuration:

1. Mode 1 (for User Interface (UI) and Electronic Image Stabilization (EIS) functionality through primary interface) and Mode 2

Figure 6. Gyroscope digital chain - Mode 1 (UI/EIS) and Mode 2

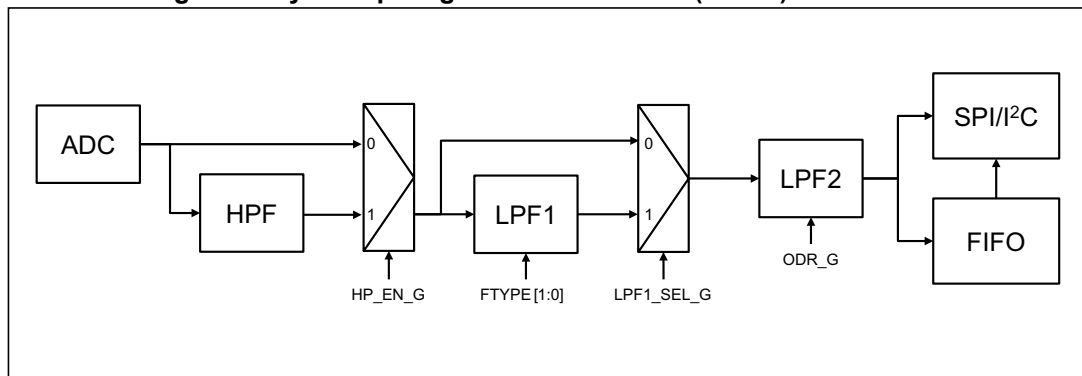

In this configuration, the gyroscope ODR is selectable from 12.5 Hz up to 6.66 kHz. A low-pass filter (LPF1) is available if the auxiliary SPI is disabled, for more details about the filter characteristics see [Table 69: Gyroscope LPF1 bandwidth selection](#).

Data can be acquired from the output registers and FIFO over the primary I²C/SPI interface.
 2. Mode 3 / Mode 4 (for OIS and EIS functionality)

Figure 7. Gyroscope digital chain - Mode 3 / Mode 4 (OIS/EIS)

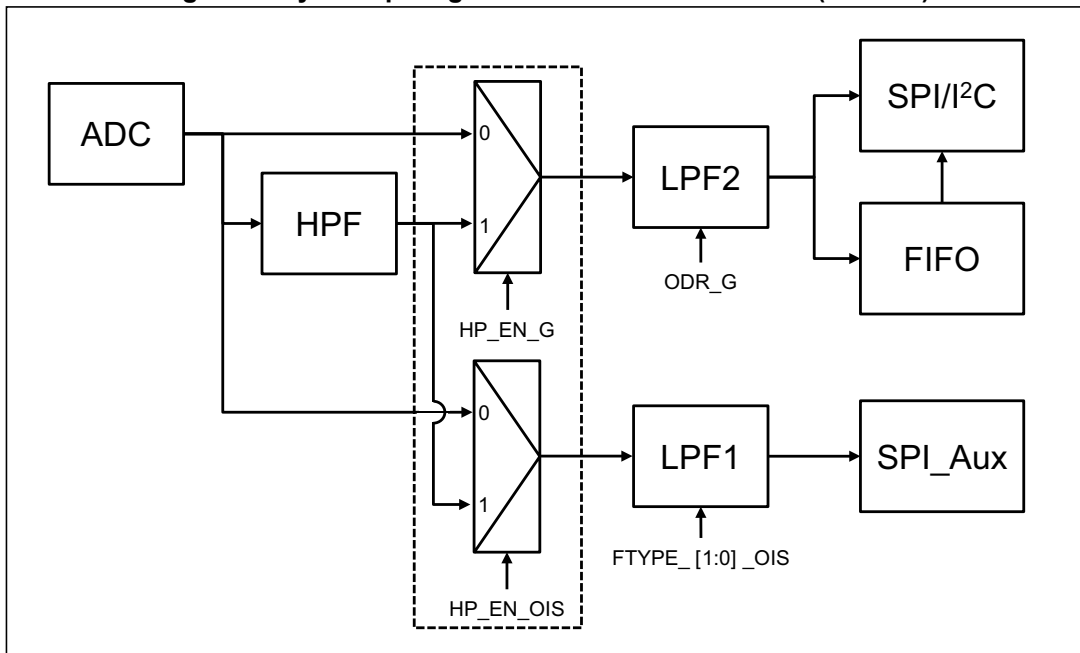

Note: HP_EN_OIS is active to select HPF on the auxiliary SPI chain only if HPF is not already used in the primary interface.

In this configuration, there are two paths:

- the chain for User Interface (UI) where the ODR is selectable from 12.5 Hz up to 6.66 kHz
- the chain for OIS/EIS where the ODR is at 6.66 kHz and the LPF1 is available. For more details about the filter characteristics see [Table 227: Gyroscope OIS chain LPF1 bandwidth selection](#).

5.4.2 Block diagrams of the accelerometer filters

In the LSM6DSM, the filtering chain for the accelerometer part is composed of the following:

- Analog filter (anti-aliasing)
- Digital filter (LPF1)
- Composite filter

Details of the block diagram appear in the following figure.

Figure 8. Accelerometer chain

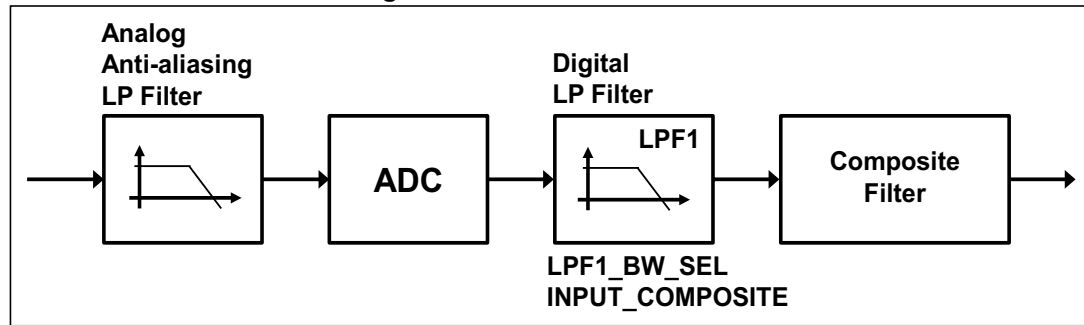

The configuration of the digital filter can be set using the LPF1_BW_SEL bit in *CTRL1_XL (10h)* and the INPUT_COMPOSITE bit in *CTRL8_XL (17h)*.

Figure 9. Accelerometer composite filter (for Modes 1/2 and Mode 3*)

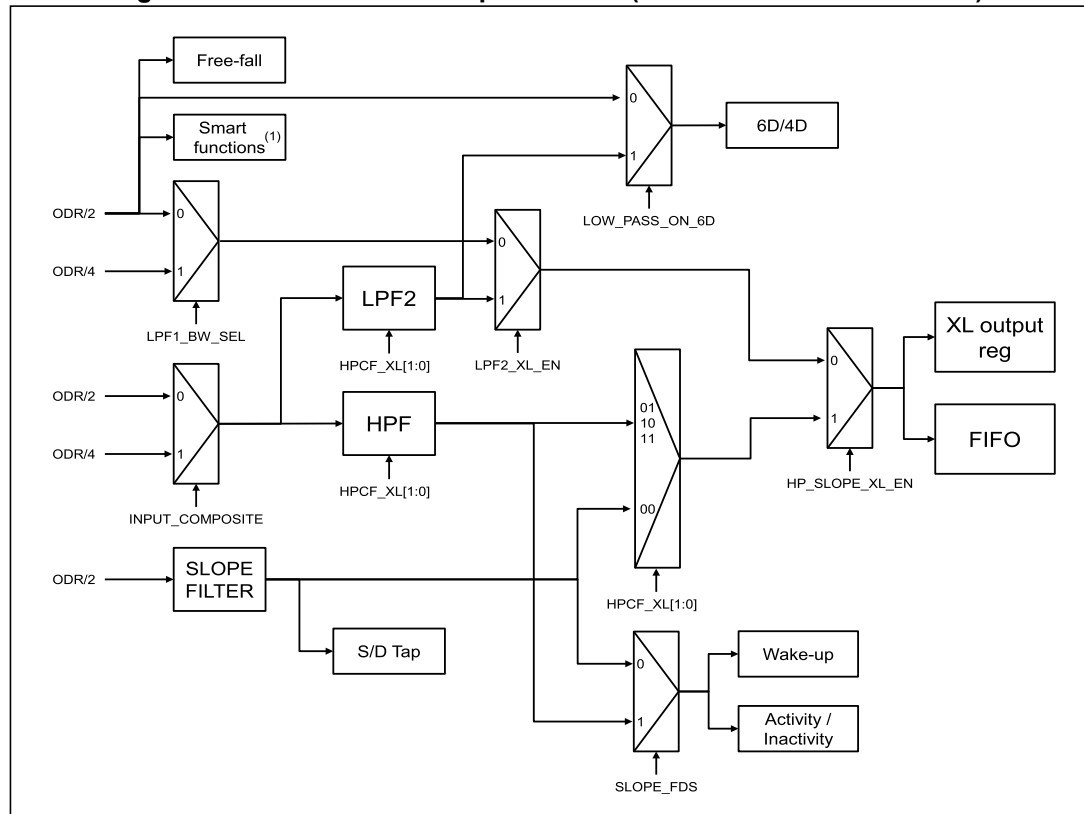

1. Pedometer, step detector and step counter, significant motion and tilt functions.

Note: * Mode 3 is available only if Mode4_EN = 0 and OIS_EN_SPI2 = 1 in *CTRL1_OIS (70h)*.

Figure 10. Accelerometer composite filter (Mode 4 only*)

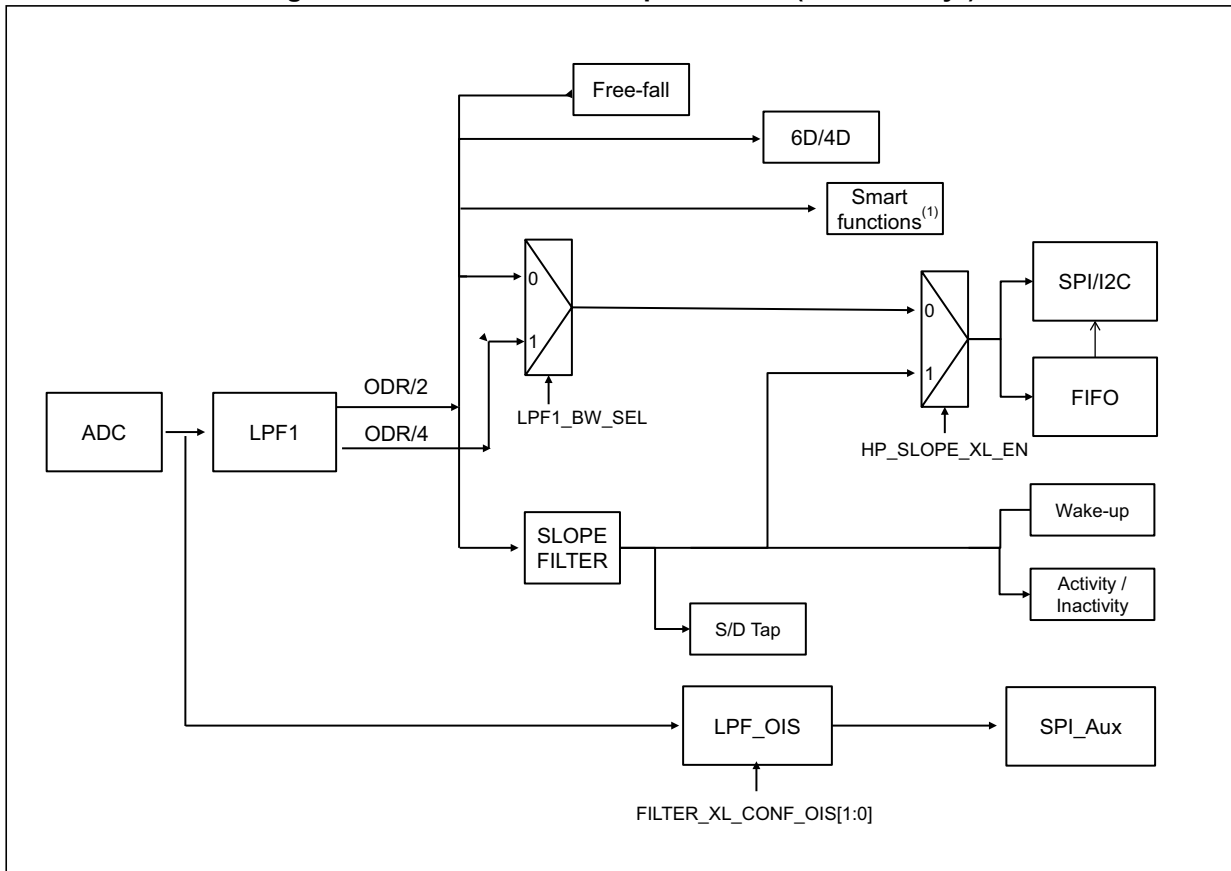

1. Pedometer, step detector and step counter, significant motion and tilt functions.

Note: *Mode 4 is enabled when Mode4_EN = 1 and OIS_EN_SPI2 = 1 in CTRL1_OIS (70h).

5.5 FIFO

The presence of a FIFO allows consistent power saving for the system since the host processor does not need continuously poll data from the sensor, but it can wake up only when needed and burst the significant data out from the FIFO.

The LSM6DSM embeds 4 kbytes data FIFO to store the following data:

- gyroscope
- accelerometer
- external sensors
- step counter and timestamp
- temperature

Writing data in the FIFO can be configured to be triggered by the:

- accelerometer/gyroscope data-ready signal; in which case the ODR must be lower than or equal to both the accelerometer and gyroscope ODRs;
- sensor hub data-ready signal;
- step detection signal.

In addition, each data can be stored at a decimated data rate compared to FIFO ODR and it is configurable by the user, setting the *FIFO_CTRL3 (08h)* and *FIFO_CTRL4 (09h)* registers. The available decimation factors are 2, 3, 4, 8, 16, 32.

The programmable FIFO threshold can be set in *FIFO_CTRL1 (06h)* and *FIFO_CTRL2 (07h)* using the FTH [10:0] bits.

To monitor the FIFO status, dedicated registers (*FIFO_STATUS1 (3Ah)*, *FIFO_STATUS2 (3Bh)*, *FIFO_STATUS3 (3Ch)*, *FIFO_STATUS4 (3Dh)*) can be read to detect FIFO overrun events, FIFO full status, FIFO empty status, FIFO threshold status and the number of unread samples stored in the FIFO. To generate dedicated interrupts on the INT1 and INT2 pads of these status events, the configuration can be set in *INT1_CTRL (0Dh)* and *INT2_CTRL (0Eh)*.

The FIFO buffer can be configured according to five different modes:

- Bypass mode
- FIFO mode
- Continuous mode
- Continuous-to-FIFO mode
- Bypass-to-continuous mode

Each mode is selected by the FIFO_MODE_[2:0] bits in the *FIFO_CTRL5 (0Ah)* register. To guarantee the correct acquisition of data during the switching into and out of FIFO mode, the first sample acquired must be discarded.

5.5.1 Bypass mode

In Bypass mode (*FIFO_CTRL5 (0Ah)* (FIFO_MODE_[2:0] = 000), the FIFO is not operational and it remains empty.

Bypass mode is also used to reset the FIFO when in FIFO mode.

5.5.2 FIFO mode

In FIFO mode (*FIFO_CTRL5 (0Ah)* (FIFO_MODE_[2:0] = 001) data from the output channels are stored in the FIFO until it is full.

To reset FIFO content, Bypass mode should be selected by writing *FIFO_CTRL5 (0Ah)* (FIFO_MODE_[2:0]) to '000'. After this reset command, it is possible to restart FIFO mode by writing *FIFO_CTRL5 (0Ah)* (FIFO_MODE_[2:0]) to '001'.

FIFO buffer memorizes up to 4096 samples of 16 bits each but the depth of the FIFO can be resized by setting the FTH [10:0] bits in *FIFO_CTRL1 (06h)* and *FIFO_CTRL2 (07h)*. If the STOP_ON_FTH bit in *FIFO_CTRL4 (09h)* is set to '1', FIFO depth is limited up to FTH [10:0] bits in *FIFO_CTRL1 (06h)* and *FIFO_CTRL2 (07h)*.

5.5.3 Continuous mode

Continuous mode (*FIFO_CTRL5 (0Ah)* (FIFO_MODE_[2:0] = 110) provides a continuous FIFO update: as new data arrives, the older data is discarded.

A FIFO threshold flag *FIFO_STATUS2 (3Bh)*(FTH) is asserted when the number of unread samples in FIFO is greater than or equal to *FIFO_CTRL1 (06h)* and *FIFO_CTRL2 (07h)*(FTH [10:0]).

It is possible to route *FIFO_STATUS2 (3Bh)* (FTH) to the INT1 pin by writing in register *INT1_CTRL (0Dh)* (INT1_FTH) = '1' or to the INT2 pin by writing in register *INT2_CTRL (0Eh)* (INT2_FTH) = '1'.

A full-flag interrupt can be enabled, *INT1_CTRL (0Dh)* (INT_FULL_FLAG) = '1', in order to indicate FIFO saturation and eventually read its content all at once.

If an overrun occurs, at least one of the oldest samples in FIFO has been overwritten and the OVER_RUN flag in *FIFO_STATUS2 (3Bh)* is asserted.

In order to empty the FIFO before it is full, it is also possible to pull from FIFO the number of unread samples available in *FIFO_STATUS1 (3Ah)* and *FIFO_STATUS2 (3Bh)* (DIFF_FIFO [10:0]).

5.5.4 Continuous-to-FIFO mode

In Continuous-to-FIFO mode (*FIFO_CTRL5 (0Ah)* (FIFO_MODE_[2:0] = 011), FIFO behavior changes according to the trigger event detected in one of the following interrupt registers *FUNC_SRC1 (53h)*, *TAP_SRC (1Ch)*, *WAKE_UP_SRC (1Bh)* and *D6D_SRC (1Dh)*.

When the selected trigger bit is equal to '1', FIFO operates in FIFO mode.

When the selected trigger bit is equal to '0', FIFO operates in Continuous mode.

5.5.5 Bypass-to-Continuous mode

In Bypass-to-Continuous mode (*FIFO_CTRL5 (0Ah)* (FIFO_MODE_[2:0] = '100'), data measurement storage inside FIFO operates in Continuous mode when selected triggers in one of the following interrupt registers *FUNC_SRC1 (53h)*, *TAP_SRC (1Ch)*, *WAKE_UP_SRC (1Bh)* and *D6D_SRC (1Dh)* are equal to '1', otherwise FIFO content is reset (Bypass mode).

5.5.6 FIFO reading procedure

The data stored in FIFO are accessible from dedicated registers (*FIFO_DATA_OUT_L (3Eh)* and *FIFO_DATA_OUT_H (3Fh)*) and each FIFO sample is composed of 16 bits.

All FIFO status registers (*FIFO_STATUS1 (3Ah)*, *FIFO_STATUS2 (3Bh)*, *FIFO_STATUS3 (3Ch)*, *FIFO_STATUS4 (3Dh)*) can be read at the start of a reading operation, minimizing the intervention of the application processor.

Saving data in the FIFO buffer is organized in four FIFO data sets consisting of 6 bytes each:

The 1st FIFO data set is reserved for gyroscope data;

The 2nd FIFO data set is reserved for accelerometer data;

The 3rd FIFO data set is reserved for the external sensor data stored in the registers from *SENSORHUB1_REG (2Eh)* to *SENSORHUB6_REG (33h)*;

The 4th FIFO data set can be alternately associated to the external sensor data stored in the registers from *SENSORHUB7_REG (34h)* to *SENSORHUB12_REG (39h)*, to the step counter and timestamp info, or to the temperature sensor data.

6 Digital interfaces

6.1 I²C/SPI interface

The registers embedded inside the LSM6DSM may be accessed through both the I²C and SPI serial interfaces. The latter may be SW configured to operate either in 3-wire or 4-wire interface mode. The device is compatible with SPI modes 0 and 3.

The serial interfaces are mapped onto the same pins. To select/exploit the I²C interface, the CS line must be tied high (i.e connected to Vdd_IO).

Table 10. Serial interface pin description

Pin name	Pin description
CS	SPI enable I ² C/SPI mode selection (1: SPI idle mode / I ² C communication enabled; 0: SPI communication mode / I ² C disabled)
SCL/SPC	I ² C Serial Clock (SCL) SPI Serial Port Clock (SPC)
SDA/SDI/SDO	I ² C Serial Data (SDA) SPI Serial Data Input (SDI) 3-wire Interface Serial Data Output (SDO)
SDO/SA0	SPI Serial Data Output (SDO) I ² C less significant bit of the device address

6.2 Master I²C

If the LSM6DSM is configured in Mode 2, a master I²C line is available. The master serial interface is mapped in the following dedicated pins.

Table 11. Master I²C pin details

Pin name	Pin description
MSCL	I ² C serial clock master
MSDA	I ² C serial data master
MDRDY	I ² C master external synchronization signal

6.3 Auxiliary SPI

If LSM6DSM is configured in Mode 3, the auxiliary SPI is available. The auxiliary SPI interface is mapped in the following dedicated pins.

Table 12. Auxiliary SPI pin details

Pin name	Pin description
OCS_Aux	Auxiliary SPI 3/4-wire enable
SDx	Auxiliary SPI 3/4-wire data input (SDI_Aux) and SPI 3-wire data output (SDO_Aux)
SCx	Auxiliary SPI 3/4-wire interface serial port clock
SDO_Aux	SPI serial data

6.4 I²C serial interface

The LSM6DSM I²C is a bus slave. The I²C is employed to write the data to the registers, whose content can also be read back.

The relevant I²C terminology is provided in the table below.

Table 13. I²C terminology

Term	Description
Transmitter	The device which sends data to the bus
Receiver	The device which receives data from the bus
Master	The device which initiates a transfer, generates clock signals and terminates a transfer
Slave	The device addressed by the master

There are two signals associated with the I²C bus: the serial clock line (SCL) and the Serial Data line (SDA). The latter is a bidirectional line used for sending and receiving the data to/from the interface. Both the lines must be connected to Vdd_IO through external pull-up resistors. When the bus is free, both the lines are high.

The I²C interface is implemented with fast mode (400 kHz) I²C standards as well as with the standard mode.

In order to disable the I²C block, (I2C_disable) = 1 must be written in [CTRL4_C \(13h\)](#).

6.4.1 I²C operation

The transaction on the bus is started through a START (ST) signal. A START condition is defined as a HIGH to LOW transition on the data line while the SCL line is held HIGH. After this has been transmitted by the master, the bus is considered busy. The next byte of data transmitted after the start condition contains the address of the slave in the first 7 bits and the eighth bit tells whether the master is receiving data from the slave or transmitting data to the slave. When an address is sent, each device in the system compares the first seven bits after a start condition with its address. If they match, the device considers itself addressed by the master.

The Slave Address (SAD) associated to the LSM6DSM is 110101xb. The SDO/SA0 pin can be used to modify the less significant bit of the device address. If the SDO/SA0 pin is connected to the supply voltage, LSb is '1' (address 1101011b); else if the SDO/SA0 pin is connected to ground, the LSb value is '0' (address 1101010b). This solution permits to connect and address two different inertial modules to the same I²C bus.

Data transfer with acknowledge is mandatory. The transmitter must release the SDA line during the acknowledge pulse. The receiver must then pull the data line LOW so that it remains stable low during the HIGH period of the acknowledge clock pulse. A receiver which has been addressed is obliged to generate an acknowledge after each byte of data received.

The I²C embedded inside the LSM6DSM behaves like a slave device and the following protocol must be adhered to. After the start condition (ST) a slave address is sent, once a slave acknowledge (SAK) has been returned, an 8-bit sub-address (SUB) is transmitted. The increment of the address is configured by the CTRL3_C (12h) (IF_INC).

The slave address is completed with a Read/Write bit. If the bit is '1' (Read), a repeated START (SR) condition must be issued after the two sub-address bytes; if the bit is '0' (Write) the master will transmit to the slave with direction unchanged. Table 14 explains how the SAD+Read/Write bit pattern is composed, listing all the possible configurations.

Table 14. SAD+Read/Write patterns

Command	SAD[6:1]	SAD[0] = SA0	R/W	SAD+R/W
Read	110101	0	1	11010101 (D5h)
Write	110101	0	0	11010100 (D4h)
Read	110101	1	1	11010111 (D7h)
Write	110101	1	0	11010110 (D6h)

Table 15. Transfer when master is writing one byte to slave

Master	ST	SAD + W		SUB		DATA		SP
Slave			SAK		SAK		SAK	

Table 16. Transfer when master is writing multiple bytes to slave

Master	ST	SAD + W		SUB		DATA		DATA		SP
Slave			SAK		SAK		SAK		SAK	

Table 17. Transfer when master is receiving (reading) one byte of data from slave

Master	ST	SAD + W		SUB		SR	SAD + R			NMAK	SP
Slave			SAK		SAK			SAK	DATA		

Table 18. Transfer when master is receiving (reading) multiple bytes of data from slave

Master	ST	SAD+W		SUB		SR	SAD+R			MAK		MAK		NMAK	SP
Slave			SAK		SAK			SAK	DATA		DATA		DATA		



Data are transmitted in byte format (DATA). Each data transfer contains 8 bits. The number of bytes transferred per transfer is unlimited. Data is transferred with the Most Significant bit (MSb) first. If a receiver can't receive another complete byte of data until it has performed some other function, it can hold the clock line, SCL LOW to force the transmitter into a wait state. Data transfer only continues when the receiver is ready for another byte and releases the data line. If a slave receiver doesn't acknowledge the slave address (i.e. it is not able to receive because it is performing some real-time function) the data line must be left HIGH by the slave. The master can then abort the transfer. A LOW to HIGH transition on the SDA line while the SCL line is HIGH is defined as a STOP condition. Each data transfer must be terminated by the generation of a STOP (SP) condition.

In the presented communication format MAK is Master acknowledge and NMAK is No Master Acknowledge.

6.5 SPI bus interface

The LSM6DSM SPI is a bus slave. The SPI allows writing and reading the registers of the device.

The serial interface communicates to the application using 4 wires: **CS**, **SPC**, **SDI** and **SDO**.

Figure 11. Read and write protocol (in mode 3)

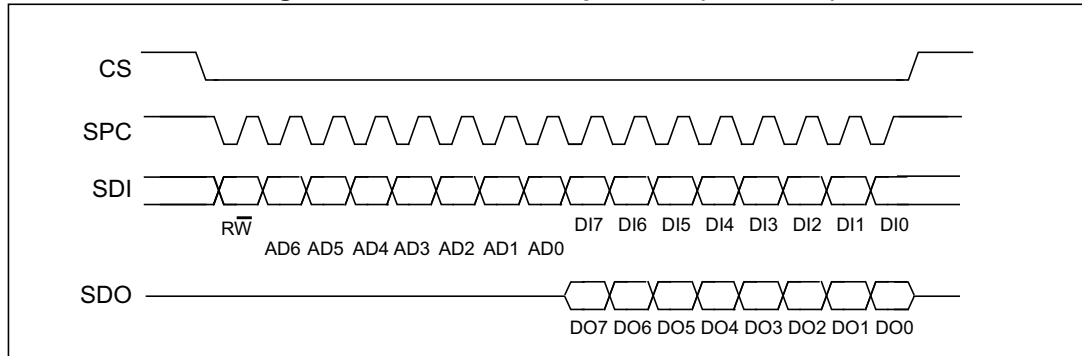

CS is the serial port enable and it is controlled by the SPI master. It goes low at the start of the transmission and goes back high at the end. **SPC** is the serial port clock and it is controlled by the SPI master. It is stopped high when **CS** is high (no transmission). **SDI** and **SDO** are, respectively, the serial port data input and output. Those lines are driven at the falling edge of **SPC** and should be captured at the rising edge of **SPC**.

Both the read register and write register commands are completed in 16 clock pulses or in multiples of 8 in case of multiple read/write bytes. Bit duration is the time between two falling edges of **SPC**. The first bit (bit 0) starts at the first falling edge of **SPC** after the falling edge of **CS** while the last bit (bit 15, bit 23, ...) starts at the last falling edge of **SPC** just before the rising edge of **CS**.

bit 0: \overline{RW} bit. When 0, the data DI(7:0) is written into the device. When 1, the data DO(7:0) from the device is read. In latter case, the chip will drive **SDO** at the start of bit 8.

bit 1-7: address AD(6:0). This is the address field of the indexed register.

bit 8-15: data DI(7:0) (write mode). This is the data that is written into the device (MSb first).

bit 8-15: data DO(7:0) (read mode). This is the data that is read from the device (MSb first).

In multiple read/write commands further blocks of 8 clock periods will be added. When the [CTRL3_C \(12h\)](#) (IF_INC) bit is '0', the address used to read/write data remains the same for every block. When the [CTRL3_C \(12h\)](#) (IF_INC) bit is '1', the address used to read/write data is increased at every block.

The function and the behavior of **SDI** and **SDO** remain unchanged.

6.5.1 SPI read

Figure 12. SPI read protocol (in mode 3)

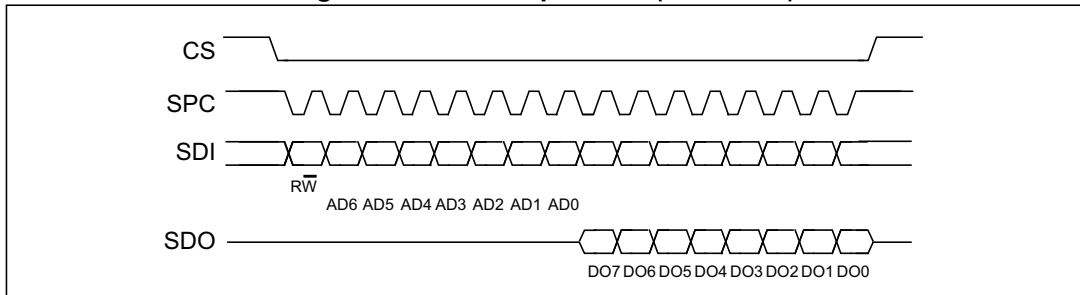

The SPI Read command is performed with 16 clock pulses. A multiple byte read command is performed by adding blocks of 8 clock pulses to the previous one.

bit 0: READ bit. The value is 1.

bit 1-7: address AD(6:0). This is the address field of the indexed register.

bit 8-15: data DO(7:0) (read mode). This is the data that will be read from the device (MSb first).

bit 16-...: data DO(...-8). Further data in multiple byte reads.

Figure 13. Multiple byte SPI read protocol (2-byte example) (in mode 3)

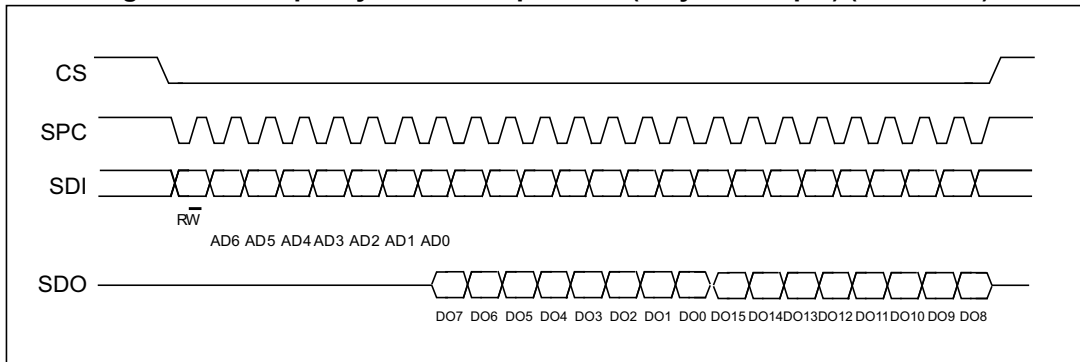

6.5.2 SPI write

Figure 14. SPI write protocol (in mode 3)

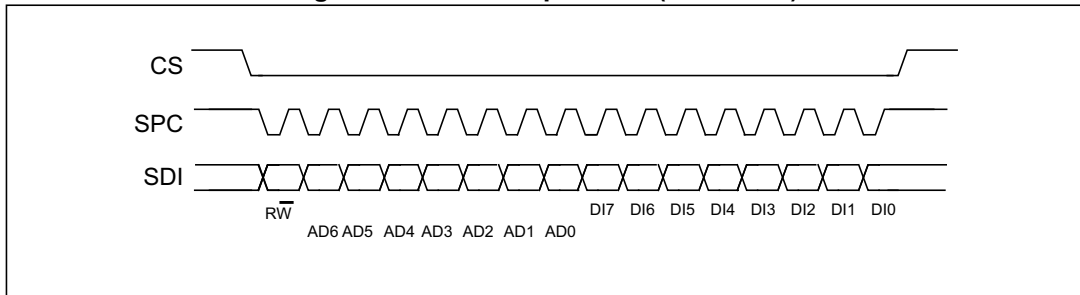

The SPI Write command is performed with 16 clock pulses. A multiple byte write command is performed by adding blocks of 8 clock pulses to the previous one.

bit 0: WRITE bit. The value is 0.

bit 1 -7: address AD(6:0). This is the address field of the indexed register.

bit 8-15: data DI(7:0) (write mode). This is the data that is written inside the device (MSb first).

bit 16-... : data DI(...-8). Further data in multiple byte writes.

Figure 15. Multiple byte SPI write protocol (2-byte example) (in mode 3)

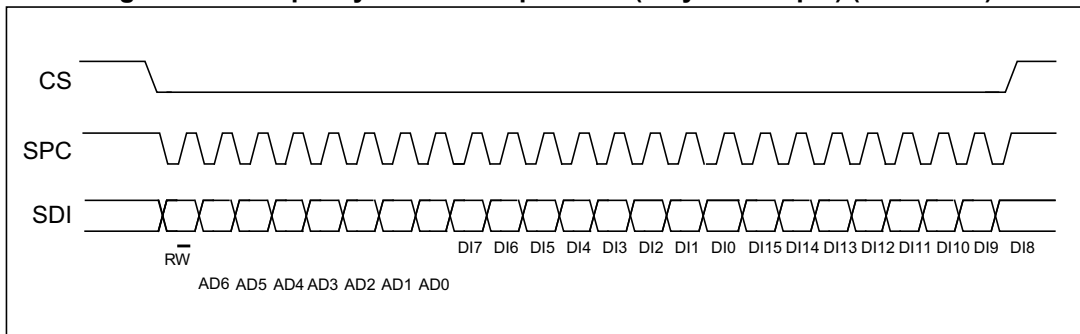

6.5.3 SPI read in 3-wire mode

A 3-wire mode is entered by setting the *CTRL3_C (12h)* (SIM) bit equal to '1' (SPI serial interface mode selection).

Figure 16. SPI read protocol in 3-wire mode (in mode 3)

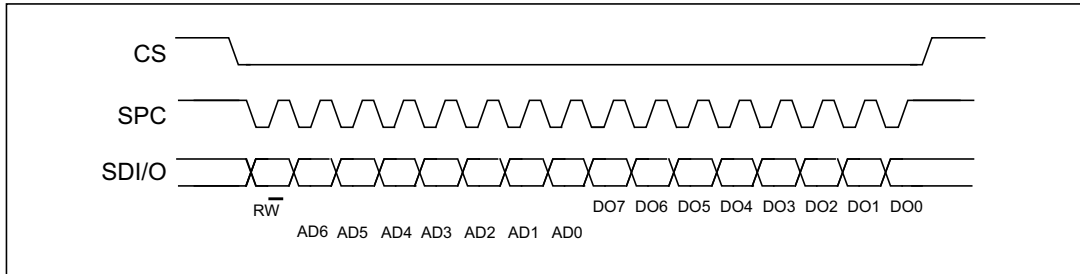

The SPI read command is performed with 16 clock pulses:

bit 0: READ bit. The value is 1.

bit 1-7: address AD(6:0). This is the address field of the indexed register.

bit 8-15: data DO(7:0) (read mode). This is the data that is read from the device (MSb first).

A multiple read command is also available in 3-wire mode.

7 Application hints

7.1 LSM6DSM electrical connections in Mode 1

Figure 17. LSM6DSM electrical connections in Mode 1

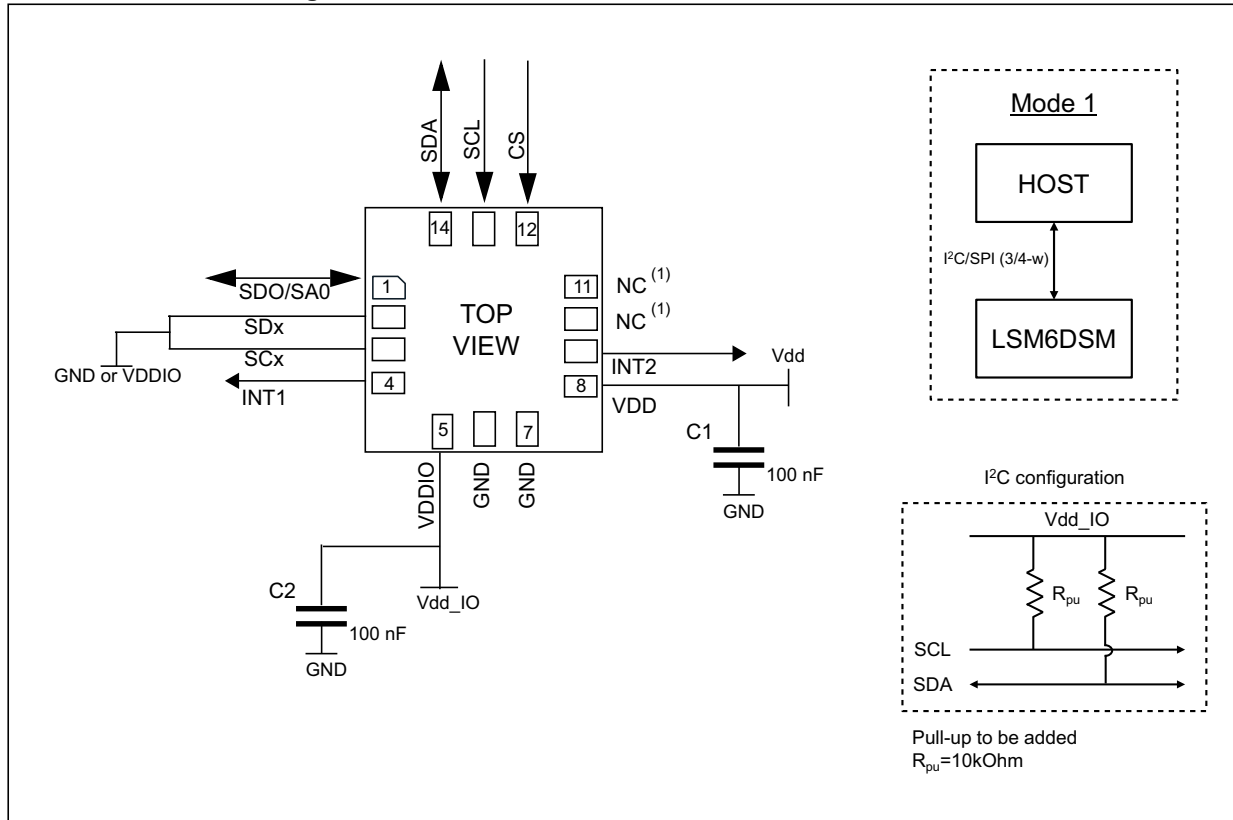

1. Leave pin electrically unconnected and soldered to PCB.

The device core is supplied through the Vdd line. Power supply decoupling capacitors (C1, C2 = 100 nF ceramic) should be placed as near as possible to the supply pin of the device (common design practice).

The functionality of the device and the measured acceleration/angular rate data is selectable and accessible through the SPI/I²C interface.

The functions, the threshold and the timing of the two interrupt pins for each sensor can be completely programmed by the user through the SPI/I²C interface.

7.2 LSM6DSM electrical connections in Mode 2

Figure 18. LSM6DSM electrical connections in Mode 2

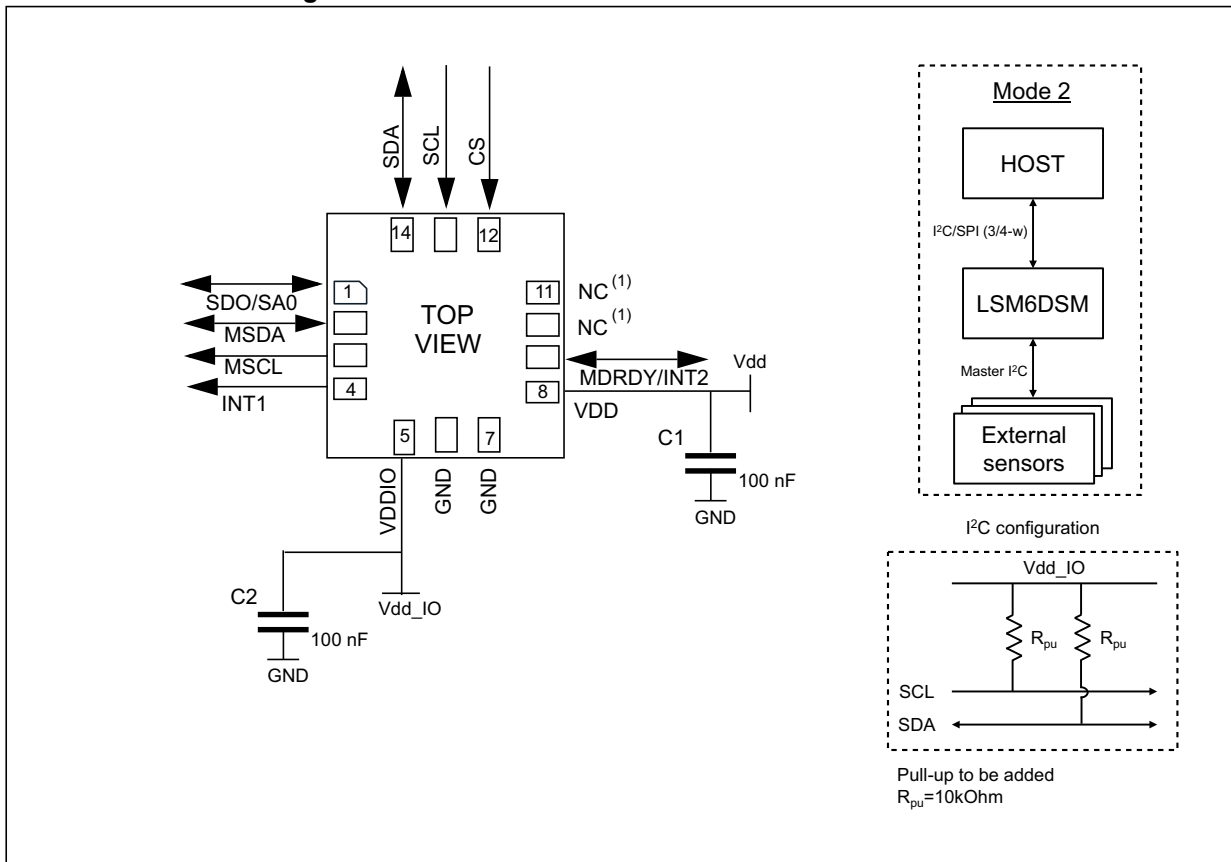

1. Leave pin electrically unconnected and soldered to PCB.

The device core is supplied through the Vdd line. Power supply decoupling capacitors (C1, C2 = 100 nF ceramic) should be placed as near as possible to the supply pin of the device (common design practice).

The functionality of the device and the measured acceleration/angular rate data is selectable and accessible through the SPI/I²C interface.

The functions, the threshold and the timing of the two interrupt pins for each sensor can be completely programmed by the user through the SPI/I²C interface.

7.3 LSM6DSM electrical connections in Mode 3 and Mode 4

Figure 19. LSM6DSM electrical connections in Mode 3 and Mode 4 (auxiliary 3-wire SPI)

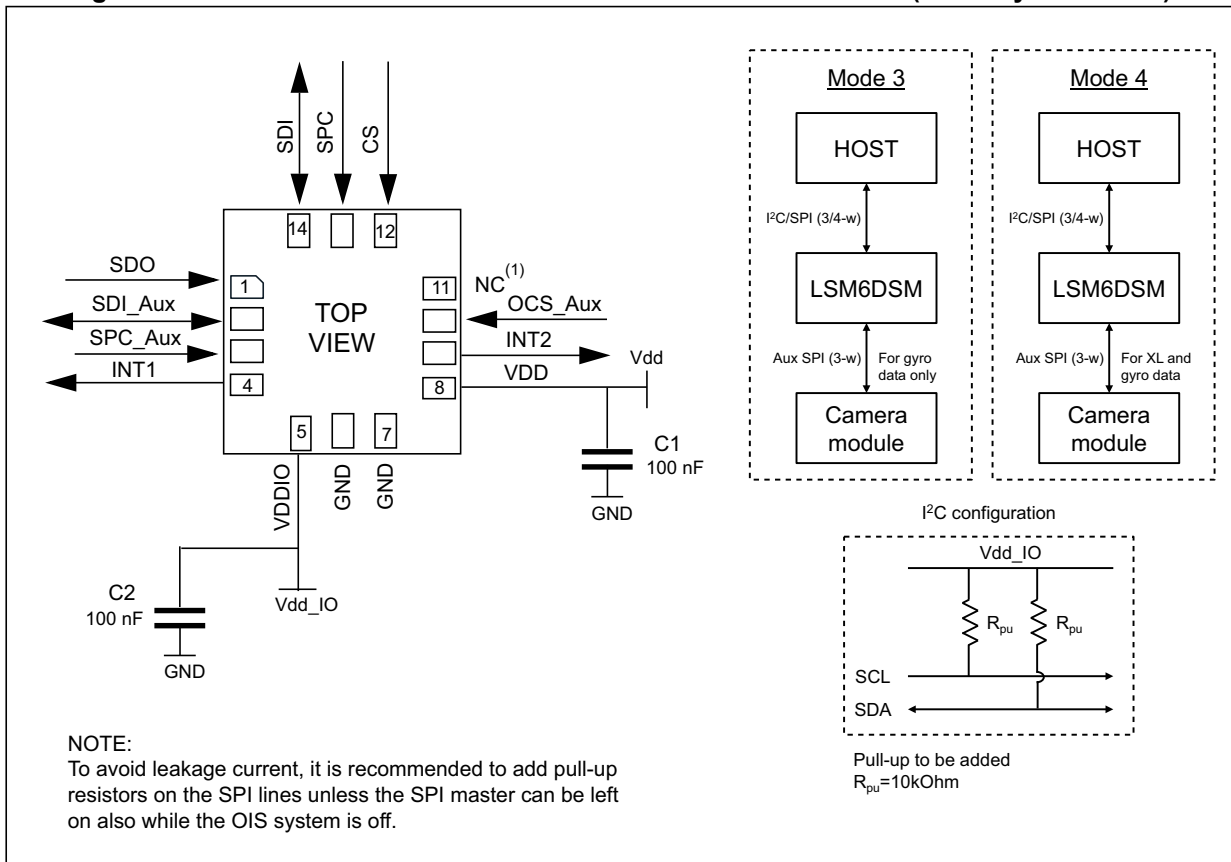

1. Leave pin electrically unconnected and soldered to PCB.

Figure 20. LSM6DSM electrical connections in Mode 3 and Mode 4 (auxiliary 4-wire SPI)

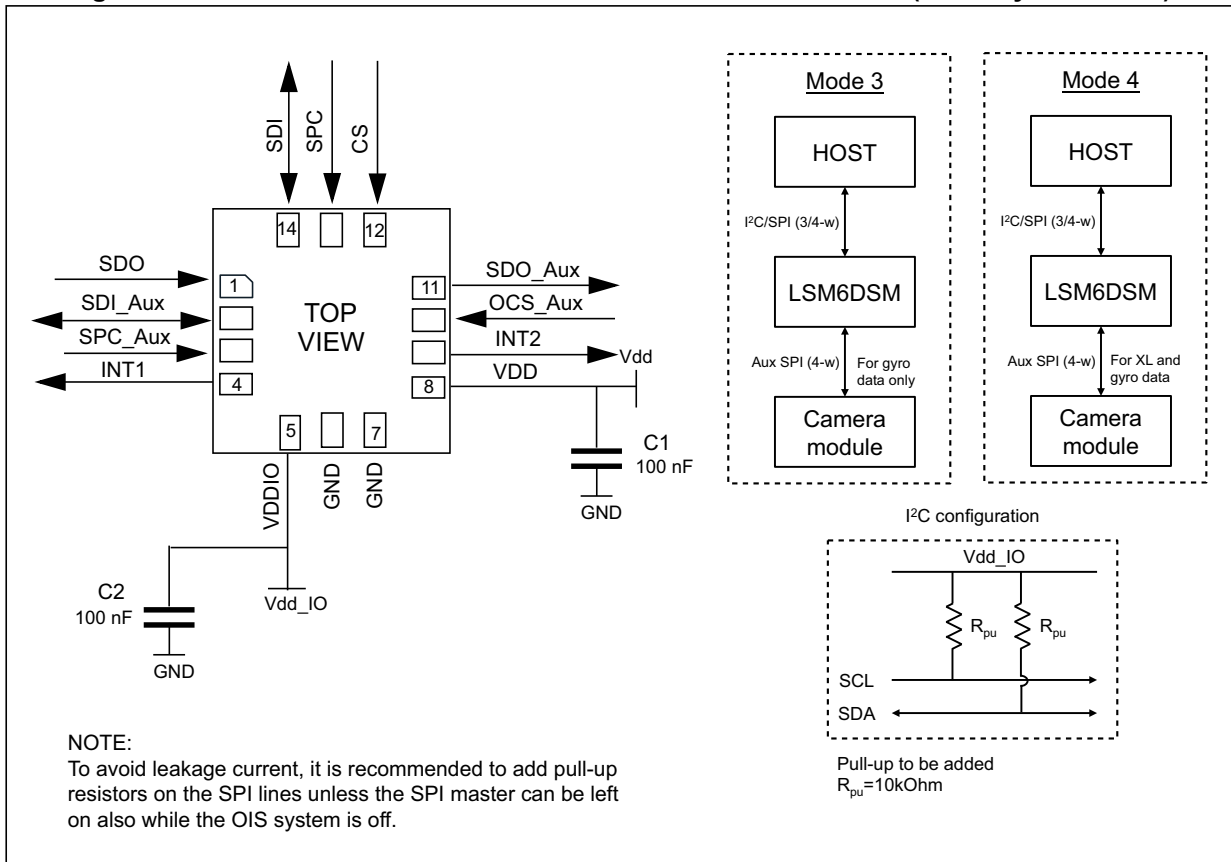

The device core is supplied through the Vdd line. Power supply decoupling capacitors (C1, C2 = 100 nF ceramic) should be placed as near as possible to the supply pin of the device (common design practice).

The functionality of the device and the measured acceleration/angular rate data is selectable and accessible through the SPI/I²C interface.

The functions, the threshold and the timing of the two interrupt pins for each sensor can be completely programmed by the user through the SPI/I²C interface.

Table 19. Internal pin status

pin#	Name	Mode 1 function	Mode 2 function	Mode 3 / Mode 4 function	Pin status Mode 1	Pin status Mode 2	Pin status Mode 3/4
1	SDO	SPI 4-wire interface serial data output (SDO)	SPI 4-wire interface serial data output (SDO)	SPI 4-wire interface serial data output (SDO)	Default: Input without pull-up. Pull-up is enabled if bit SIM = 1 (SPI 3-wire) in reg 12h.	Default: Input without pull-up. Pull-up is enabled if bit SIM = 1 (SPI 3-wire) in reg 12h.	Default: Input without pull-up. Pull-up is enabled if bit SIM = 1 (SPI 3-wire) in reg 12h.
	SA0	I ² C least significant bit of the device address (SA0)	I ² C least significant bit of the device address (SA0)	I ² C least significant bit of the device address (SA0)			
2	SDx	Connect to VDDIO or GND	I ² C serial data master (MSDA)	Auxiliary SPI 3/4-wire interface serial data input (SDI) and SPI 3-wire serial data output (SDO)	Default: input without pull-up. Pull-up is enabled if bit PULL_UP_EN = 1 in reg 1Ah.	Default: input without pull-up. Pull-up is enabled if bit PULL_UP_EN = 1 in reg 1Ah.	Default: input without pull-up. Pull-up is enabled if bit PULL_UP_EN = 1 in reg 1Ah.
3	SCx	Connect to VDDIO or GND	I ² C serial clock master (MSCL)	Auxiliary SPI 3/4-wire interface serial port clock (SPC_Aux)	Default: input without pull-up. Pull-up is enabled if bit PULL_UP_EN = 1 in reg 1Ah.	Default: input without pull-up. Pull-up is enabled if bit PULL_UP_EN = 1 in reg 1Ah.	Default: input without pull-up. Pull-up is enabled if bit PULL_UP_EN = 1 in reg 1Ah.
4	INT1	Programmable interrupt 1	Programmable interrupt 1	Programmable interrupt 1	Default: Output forced to ground	Default: Output forced to ground	Default: Output forced to ground
5	Vdd_IO	Power supply for I/O pins	Power supply for I/O pins	Power supply for I/O pins			
6	GND	0 V supply	0 V supply	0 V supply			
7	GND	0 V supply	0 V supply	0 V supply			
8	Vdd	Power supply	Power supply	Power supply			
9	INT2	Programmable interrupt 2 (INT2) / Data enabled (DEN)	Programmable interrupt 2 (INT2) / Data enabled (DEN) / I ² C master external synchronization signal (MDRDY)	Programmable interrupt 2 (INT2) / Data enabled (DEN)	Default: Output forced to ground	Default: Output forced to ground	Default: Output forced to ground

Table 19. Internal pin status (continued)

pin#	Name	Mode 1 function	Mode 2 function	Mode 3 / Mode 4 function	Pin status Mode 1	Pin status Mode 2	Pin status Mode 3/4
10	OCS_Aux	Leave unconnected	Leave unconnected	Auxiliary SPI 3/4-wire interface enabled	Default: Input with pull-up. (See note below to disable pull-up)	Default: Input with pull-up. (See note below to disable pull-up)	Input without pull-up
11	SDO_Aux	Connect to VDDIO or leave unconnected	Connect to VDDIO or leave unconnected	Auxiliary SPI 3-wire interface: leave unconnected / Auxiliary SPI 4-wire interface: serial data output (SDO_Aux)	Default: Input with pull-up. (See note below to disable pull-up)	Default: Input with pull-up. (See note below to disable pull-up)	Default: Input without pull-up. Pull-up is enabled if bit SIM_OIS = 1 (Aux_SPI 3-wire) in reg 70h.
12	CS	I ² C/SPI mode selection (1:SPI idle mode / I ² C communication enabled; 0: SPI communication mode / I ² C disabled)	I ² C/SPI mode selection (1:SPI idle mode / I ² C communication enabled; 0: SPI communication mode / I ² C disabled)	I ² C/SPI mode selection (1:SPI idle mode / I ² C communication enabled; 0: SPI communication mode / I ² C disabled)	Default: Input with pull-up. Pull-up is disabled if bit I2C_disable = 1 in reg 13h.	Default: Input with pull-up. Pull-up is disabled if bit I2C_disable = 1 in reg 13h.	Default: Input with pull-up. Pull-up is disabled if bit I2C_disable = 1 in reg 13h.
13	SCL	I ² C serial clock (SCL) / SPI serial port clock (SPC)	I ² C serial clock (SCL) / SPI serial port clock (SPC)	I ² C serial clock (SCL) / SPI serial port clock (SPC)	Input without pull-up	Input without pull-up	Input without pull-up
14	SDA	I ² C serial data (SDA) / SPI serial data input (SDI) / 3-wire interface serial data output (SDO)	I ² C serial data (SDA) / SPI serial data input (SDI) / 3-wire interface serial data output (SDO)	I ² C serial data (SDA) / SPI serial data input (SDI) / 3-wire interface serial data output (SDO)	Input without pull-up	Input without pull-up	Input without pull-up

Internal pull-up value is from 30 kΩ to 50 kΩ, depending on VDDIO.

Note: *The procedure to disable the pull-up on pins 10-11 is as follows:*

1. *AP side: write 80h in register at address 00h*
2. *AP side: write 01h in register at address 05h (disable the pull-up on pins 10 and 11 of LSM6DSM)*
3. *AP side: write 00h in register at address 00h*

8 Auxiliary SPI configurations

When the LSM6DSM is configured in Mode 3 and Mode 4, the auxiliary SPI can be connected to a camera module for OIS/EIS support. In this interface, the SPI can write only to the dedicated registers *INT_OIS (6Fh)*, *CTRL1_OIS (70h)*, *CTRL2_OIS (71h)*, *CTRL3_OIS (72h)*.

8.1 Gyroscope filtering

The gyroscope filtering chain is illustrated in the following figure.

Figure 21. Gyroscope chain

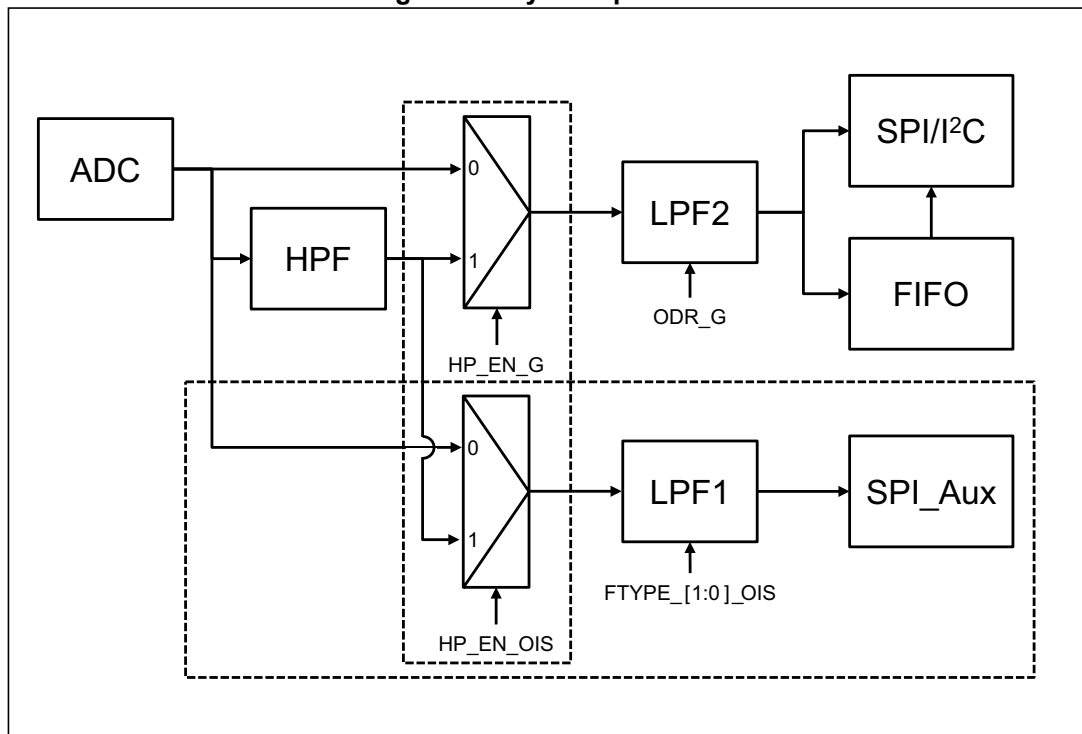

Note: *HP_EN_OIS* is active to select HPF on the auxiliary SPI chain only if HPF is not already used in the primary interface.

The auxiliary interface needs to be enabled in *CTRL1_OIS (70h)*.

Gyroscope output values are in registers 22h to 27h with selected full scale (FS[1:0]_G_OIS bit in *CTRL1_OIS (70h)*) and ODR at 6.66 kHz.

LPF1 configuration depends on the setting of the FTYPE_[1:0]_OIS bit in register *CTRL2_OIS (71h)*.

8.2 Accelerometer filtering

Accelerometer filtering is available only when Mode 4 is enabled.

Figure 22. Accelerometer chain (available only in Mode 4)

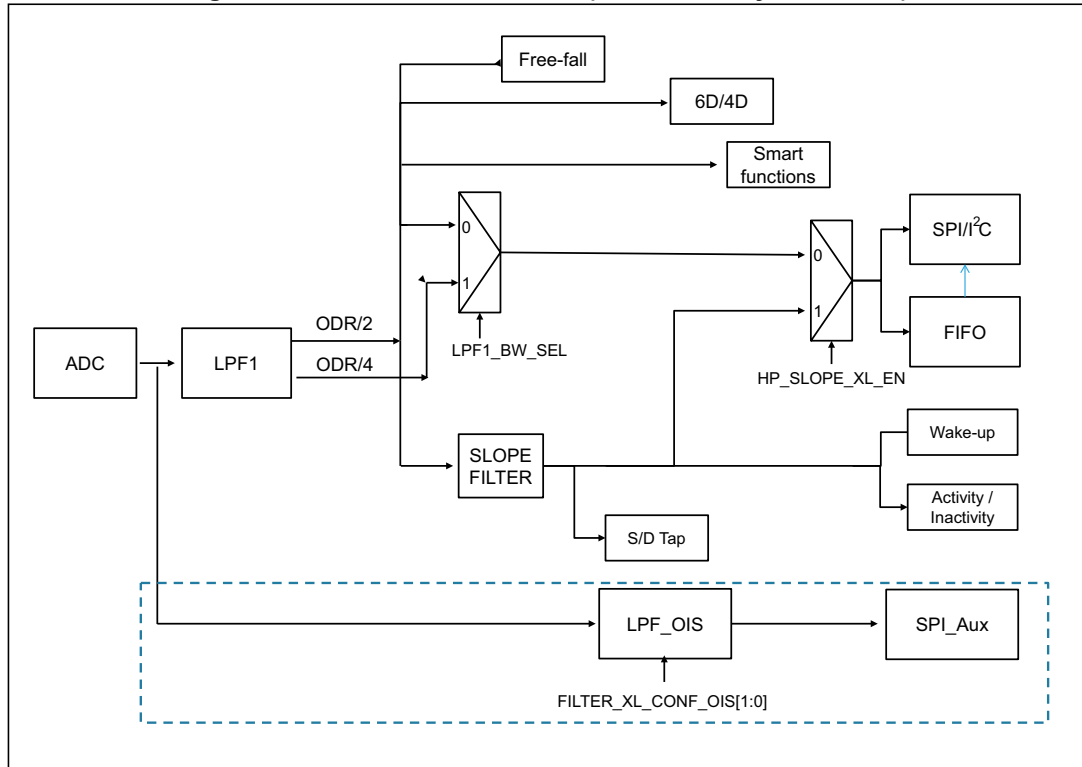

Accelerometer output values are in registers [OUTX_L_XL \(28h\)](#) through [OUTZ_H_XL \(2Dh\)](#) and ODR at 6.66 kHz.

8.2.1 Accelerometer full scale set from primary interface

If the SPI/I²C primary interface is used, the full-scale setting has been configured by the primary interface and [CTRL3_OIS \(72h\)](#) must be set to the same full-scale setting of the primary interface.

8.2.2 Accelerometer full scale set from auxiliary SPI

If the configuration uses only the auxiliary SPI, the full scale can be set using the FS[1:0]_{XL_OIS} bits in [CTRL3_OIS \(72h\)](#). The configuration of the low-pass filter depends on the setting of the FILTER_XL_CONF_OIS[1:0] bits in register [CTRL3_OIS \(72h\)](#).

9 Register mapping

The table given below provides a list of the 8/16-bit registers embedded in the device and the corresponding addresses.

Table 20. Registers address map

Name	Type	Register address		Default	Comment
		Hex	Binary		
RESERVED	-	00	00000000	-	Reserved
FUNC_CFG_ACCESS	r/w	01	00000001	00000000	Embedded functions configuration register
RESERVED	-	02	00000010	-	Reserved
RESERVED	-	03	00000011	-	Reserved
SENSOR_SYNC_TIME_FRAME	r/w	04	00000100	00000000	Sensor sync configuration register
SENSOR_SYNC_RES_RATIO	r/w	05	00000101	00000000	
FIFO_CTRL1	r/w	06	00000110	00000000	FIFO configuration registers
FIFO_CTRL2	r/w	07	00000111	00000000	
FIFO_CTRL3	r/w	08	00001000	00000000	
FIFO_CTRL4	r/w	09	00001001	00000000	
FIFO_CTRL5	r/w	0A	00001010	00000000	
DRDY_PULSE_CFG	r/w	0B	00001011	00000000	
RESERVED	-	0C	00001100	-	Reserved
INT1_CTRL	r/w	0D	00001101	00000000	INT1 pin control
INT2_CTRL	r/w	0E	00001110	00000000	INT2 pin control
WHO_AM_I	r	0F	00001111	01101010	Who I am ID
CTRL1_XL	r/w	10	00010000	00000000	Accelerometer and gyroscope control registers
CTRL2_G	r/w	11	00010001	00000000	
CTRL3_C	r/w	12	00010010	00000100	
CTRL4_C	r/w	13	00010011	00000000	
CTRL5_C	r/w	14	00010100	00000000	
CTRL6_C	r/w	15	00010101	00000000	
CTRL7_G	r/w	16	00010110	00000000	
CTRL8_XL	r/w	17	0001 0111	00000000	
CTRL9_XL	r/w	18	00011000	11100000	
CTRL10_C	r/w	19	00011001	00000000	

Table 20. Registers address map (continued)

Name	Type	Register address		Default	Comment
		Hex	Binary		
MASTER_CONFIG	r/w	1A	00011010	00000000	I ² C master configuration register
WAKE_UP_SRC	r	1B	00011011	output	Interrupt registers
TAP_SRC	r	1C	00011100	output	
D6D_SRC	r	1D	00011101	output	
STATUS_REG ⁽¹⁾ / STATUS_SPIAux ⁽²⁾	r	1E	00011110	output	Status data register for user interface and OIS data
RESERVED	-	1F	00011111	-	Reserved
OUT_TEMP_L	r	20	00100000	output	Temperature output data registers
OUT_TEMP_H	r	21	00100001	output	
OUTX_L_G	r	22	00100010	output	Gyroscope output registers for user interface and OIS data
OUTX_H_G	r	23	00100011	output	
OUTY_L_G	r	24	00100100	output	
OUTY_H_G	r	25	00100101	output	
OUTZ_L_G	r	26	00100110	output	
OUTZ_H_G	r	27	00100111	output	
OUTX_L_XL	r	28	00101000	output	Accelerometer output registers
OUTX_H_XL	r	29	00101001	output	
OUTY_L_XL	r	2A	00101010	output	
OUTY_H_XL	r	2B	00101011	output	
OUTZ_L_XL	r	2C	00101100	output	
OUTZ_H_XL	r	2D	00101101	output	
SENSORHUB1_REG	r	2E	00101110	output	Sensor hub output registers
SENSORHUB2_REG	r	2F	00101111	output	
SENSORHUB3_REG	r	30	00110000	output	
SENSORHUB4_REG	r	31	00110001	output	
SENSORHUB5_REG	r	32	00110010	output	
SENSORHUB6_REG	r	33	00110011	output	
SENSORHUB7_REG	r	34	00110100	output	
SENSORHUB8_REG	r	35	00110101	output	
SENSORHUB9_REG	r	36	00110110	output	
SENSORHUB10_REG	r	37	00110111	output	
SENSORHUB11_REG	r	38	00111000	output	
SENSORHUB12_REG	r	39	00111001	output	

Table 20. Registers address map (continued)

Name	Type	Register address		Default	Comment
		Hex	Binary		
FIFO_STATUS1	r	3A	00111010	output	FIFO status registers
FIFO_STATUS2	r	3B	00111011	output	
FIFO_STATUS3	r	3C	00111100	output	
FIFO_STATUS4	r	3D	00111101	output	
FIFO_DATA_OUT_L	r	3E	00111110	output	FIFO data output registers
FIFO_DATA_OUT_H	r	3F	00111111	output	
TIMESTAMP0_REG	r	40	01000000	output	Timestamp output registers
TIMESTAMP1_REG	r	41	01000001	output	
TIMESTAMP2_REG	r/w	42	01000010	output	
RESERVED	-	43-48		-	Reserved
STEP_TIMESTAMP_L	r	49	0100 1001	output	Step counter timestamp registers
STEP_TIMESTAMP_H	r	4A	0100 1010	output	
STEP_COUNTER_L	r	4B	01001011	output	Step counter output registers
STEP_COUNTER_H	r	4C	01001100	output	
SENSORHUB13_REG	r	4D	01001101	output	Sensor hub output registers
SENSORHUB14_REG	r	4E	01001110	output	
SENSORHUB15_REG	r	4F	01001111	output	
SENSORHUB16_REG	r	50	01010000	output	
SENSORHUB17_REG	r	51	01010001	output	
SENSORHUB18_REG	r	52	01010010	output	
FUNC_SRC1	r	53	01010011	output	Interrupt registers
FUNC_SRC2	r	54	01010100	output	
WRIST_TILT_IA	r	55	01010101	output	Interrupt register
RESERVED	-	56-57		-	Reserved
TAP_CFG	r/w	58	01011000	00000000	Interrupt registers
TAP_THS_6D	r/w	59	01011001	00000000	
INT_DUR2	r/w	5A	01011010	00000000	
WAKE_UP_THS	r/w	5B	01011011	00000000	
WAKE_UP_DUR	r/w	5C	01011100	00000000	
FREE_FALL	r/w	5D	01011101	00000000	
MD1_CFG	r/w	5E	01011110	00000000	
MD2_CFG	r/w	5F	01011111	00000000	
MASTER_CMD_CODE	r/w	60	01100000	00000000	

Table 20. Registers address map (continued)

Name	Type	Register address		Default	Comment
		Hex	Binary		
SENS_SYNC_SPI_ERROR_CODE	r/w	61	0110 0001	00000000	
RESERVED	-	62-65		-	Reserved
OUT_MAG_RAW_X_L	r	66	01100110	output	External magnetometer raw data output registers
OUT_MAG_RAW_X_H	r	67	01100111	output	
OUT_MAG_RAW_Y_L	r	68	01101000	output	
OUT_MAG_RAW_Y_H	r	69	01101001	output	
OUT_MAG_RAW_Z_L	r	6A	01101010	output	
OUT_MAG_RAW_Z_H	r	6B	01101011	output	
RESERVED	-	6C-6E		-	Reserved
INT_OIS	r/w	6F	01101111	00000000	
CTRL1_OIS	r/w	70	01110000	00000000	Control registers for OIS connection
CTRL2_OIS	r/w	71	01110001	00000000	
CTRL3_OIS	r/w	72	01110010	00000000	
X_OFS_USR	r/w	73	01110011	00000000	Accelerometer user offset correction
Y_OFS_USR	r/w	74	01110100	00000000	
Z_OFS_USR	r/w	75	01110101	00000000	
RESERVED	-	76-7F		-	Reserved

1. This register status is read using the primary interface for user interface data.
2. This register status is read using the auxiliary SPI for OIS data.

10 Register description

The device contains a set of registers which are used to control its behavior and to retrieve linear acceleration, angular rate and temperature data. The register addresses, made up of 7 bits, are used to identify them and to write the data through the serial interface.

10.1 FUNC_CFG_ACCESS (01h)

Enable embedded functions register (r/w).

Table 21. FUNC_CFG_ACCESS register

FUNC_CFG_EN	0 ⁽¹⁾	FUNC_CFG_EN_B	0 ⁽¹⁾	0 ⁽¹⁾	0 ⁽¹⁾	0 ⁽¹⁾	0 ⁽¹⁾
-------------	------------------	---------------	------------------	------------------	------------------	------------------	------------------

1. This bit must be set to '0' for the correct operation of the device.

Table 22. FUNC_CFG_ACCESS register description

FUNC_CFG_EN	Enable access to the embedded functions configuration registers bank A and B ⁽¹⁾ . Default value: 0. Refer to Table 23 .
FUNC_CFG_EN_B	Enable access to the embedded functions configuration register bank B ⁽¹⁾ . Default value: 0. Refer to Table 23 .

1. The embedded functions configuration registers details are available in [Section 11: Embedded functions register mapping](#), [Section 12: Embedded functions registers description - Bank A](#), and [Section 13: Embedded functions registers description - Bank B](#).

Table 23. Configuration of embedded functions register banks

FUNC_CFG_EN	FUNC_CFG_EN_B	Status of embedded register banks
0	0	Bank A and B disabled (default)
0	1	Forbidden
1	0	Bank A enabled
1	1	Bank B enabled

10.2 SENSOR_SYNC_TIME_FRAME (04h)

Sensor synchronization time frame register (r/w).

Table 24. SENSOR_SYNC_TIME_FRAME register

0 ⁽¹⁾	0 ⁽¹⁾	0 ⁽¹⁾	0 ⁽¹⁾	TPH_3	TPH_2	TPH_1	TPH_0
------------------	------------------	------------------	------------------	-------	-------	-------	-------

1. This bit must be set to '0' for the correct operation of the device.

Table 25. SENSOR_SYNC_TIME_FRAME register description

TPH_ [3:0]	Sensor synchronization time frame with the step of 500 ms and full range of 5 s. Unsigned 8-bit. Default value: 0000 0000 (sensor sync disabled)
------------	--

10.3 SENSOR_SYNC_RES_RATIO (05h)

Sensor synchronization resolution ratio (r/w)

Table 26. SENSOR_SYNC_RES_RATIO register

0 ⁽¹⁾	0 ⁽¹⁾	0 ⁽¹⁾	0 ⁽¹⁾	0 ⁽¹⁾	0 ⁽¹⁾	RR_1	RR_0
------------------	------------------	------------------	------------------	------------------	------------------	------	------

1. This bit must be set to '0' for the correct operation of the device.

Table 27. SENSOR_SYNC_RES_RATIO register description

RR_[1:0]	Resolution ratio of error code for sensor synchronization:
	00: SensorSync, Res_Ratio = 2-11
	01: SensorSync, Res_Ratio = 2-12
	10: SensorSync, Res_Ratio = 2-13
	11: SensorSync, Res_Ratio = 2-14

10.4 FIFO_CTRL1 (06h)

FIFO control register (r/w).

Table 28. FIFO_CTRL1 register

FTH_7	FTH_6	FTH_5	FTH_4	FTH_3	FTH_2	FTH_1	FTH_0
-------	-------	-------	-------	-------	-------	-------	-------

Table 29. FIFO_CTRL1 register description

FTH_[7:0]	FIFO threshold level setting ⁽¹⁾ . Default value: 0000 0000.
	Watermark flag rises when the number of bytes written to FIFO after the next write is greater than or equal to the threshold level.
	Minimum resolution for the FIFO is 1 LSB = 2 bytes (1 word) in FIFO

1. For a complete watermark threshold configuration, consider FTH_[10:8] in [FIFO_CTRL2 \(07h\)](#).

10.5 FIFO_CTRL2 (07h)

FIFO control register (r/w).

Table 30. FIFO_CTRL2 register

TIMER_PEDO_FIF0_EN	TIMER_PEDO_FIF0_DRDY	0 ⁽¹⁾	0 ⁽¹⁾	FIFO_TEMP_EN	FTH10	FTH_9	FTH_8
--------------------	----------------------	------------------	------------------	--------------	-------	-------	-------

1. This bit must be set to '0' for the correct operation of the device.

Table 31. FIFO_CTRL2 register description

TIMER_PEDO_FIF0_EN	Enable pedometer step counter and timestamp as 4 th FIFO data set. Default: 0 (0: disable step counter and timestamp data as 4 th FIFO data set; 1: enable step counter and timestamp data as 4 th FIFO data set)
TIMER_PEDO_FIF0_DRDY	FIFO write mode ⁽¹⁾ . Default: 0 (0: enable write in FIFO based on XL/Gyro data-ready; 1: enable write in FIFO at every step detected by step counter.)
FIFO_TEMP_EN	Enable the temperature data storage in FIFO. Default: 0. (0: temperature not included in FIFO; 1: temperature included in FIFO)
FTH_[10:8]	FIFO threshold level setting ⁽²⁾ . Default value: 0000 Watermark flag rises when the number of bytes written to FIFO after the next write is greater than or equal to the threshold level. Minimum resolution for the FIFO is 1LSB = 2 bytes (1 word) in FIFO

1. This bit is effective if the DATA_VALID_SEL_FIF0 bit of the *MASTER_CONFIG (1Ah)* register is set to 0.
2. For a complete watermark threshold configuration, consider FTH_[7:0] in *FIFO_CTRL1 (06h)*

10.6 FIFO_CTRL3 (08h)

FIFO control register (r/w).

Table 32. FIFO_CTRL3 register

0 ⁽¹⁾	0 ⁽¹⁾	DEC_FIFO_GYRO2	DEC_FIFO_GYRO1	DEC_FIFO_GYRO0	DEC_FIFO_XL2	DEC_FIFO_XL1	DEC_FIFO_XL0
------------------	------------------	----------------	----------------	----------------	--------------	--------------	--------------

1. This bit must be set to '0' for the correct operation of the device.

Table 33. FIFO_CTRL3 register description

DEC_FIFO_GYRO [2:0]	Gyro FIFO (first data set) decimation setting. Default: 000 For the configuration setting, refer to Table 34 .
DEC_FIFO_XL [2:0]	Accelerometer FIFO (second data set) decimation setting. Default: 000 For the configuration setting, refer to Table 35 .

Table 34. Gyro FIFO decimation setting

DEC_FIFO_GYRO [2:0]	Configuration
000	Gyro sensor not in FIFO
001	No decimation
010	Decimation with factor 2
011	Decimation with factor 3
100	Decimation with factor 4
101	Decimation with factor 8
110	Decimation with factor 16
111	Decimation with factor 32

Table 35. Accelerometer FIFO decimation setting

DEC_FIFO_XL [2:0]	Configuration
000	Accelerometer sensor not in FIFO
001	No decimation
010	Decimation with factor 2
011	Decimation with factor 3
100	Decimation with factor 4
101	Decimation with factor 8
110	Decimation with factor 16
111	Decimation with factor 32

10.7 FIFO_CTRL4 (09h)

FIFO control register (r/w).

Table 36. FIFO_CTRL4 register

STOP_ON_FTH	ONLY_HIGH_DATA	DEC_DS4_FIFO2	DEC_DS4_FIFO1	DEC_DS4_FIFO0	DEC_DS3_FIFO2	DEC_DS3_FIFO1	DEC_DS3_FIFO0
-------------	----------------	---------------	---------------	---------------	---------------	---------------	---------------

Table 37. FIFO_CTRL4 register description

STOP_ON_FTH	Enable FIFO threshold level use. Default value: 0. (0: FIFO depth is not limited; 1: FIFO depth is limited to threshold level)
ONLY_HIGH_DATA	8-bit data storage in FIFO. Default: 0 (0: disable MSByte only memorization in FIFO for XL and Gyro; 1: enable MSByte only memorization in FIFO for XL and Gyro in FIFO)
DEC_DS4_FIFO[2:0]	Fourth FIFO data set decimation setting. Default: 000 For the configuration setting, refer to Table 38 .
DEC_DS3_FIFO[2:0]	Third FIFO data set decimation setting. Default: 000 For the configuration setting, refer to Table 39 .

Table 38. Fourth FIFO data set decimation setting

DEC_DS4_FIFO[2:0]	Configuration
000	Fourth FIFO data set not in FIFO
001	No decimation
010	Decimation with factor 2
011	Decimation with factor 3
100	Decimation with factor 4
101	Decimation with factor 8
110	Decimation with factor 16
111	Decimation with factor 32

Table 39. Third FIFO data set decimation setting

DEC_DS3_FIFO[2:0]	Configuration
000	Third FIFO data set not in FIFO
001	No decimation
010	Decimation with factor 2
011	Decimation with factor 3
100	Decimation with factor 4
101	Decimation with factor 8
110	Decimation with factor 16
111	Decimation with factor 32

10.8 FIFO_CTRL5 (0Ah)

FIFO control register (r/w).

Table 40. FIFO_CTRL5 register

0 ⁽¹⁾	ODR_FIFO_3	ODR_FIFO_2	ODR_FIFO_1	ODR_FIFO_0	FIFO_MODE_2	FIFO_MODE_1	FIFO_MODE_0
------------------	------------	------------	------------	------------	-------------	-------------	-------------

1. This bit must be set to '0' for the correct operation of the device.

Table 41. FIFO_CTRL5 register description

ODR_FIFO_[3:0]	FIFO ODR selection, setting FIFO_MODE also. Default: 0000 For the configuration setting, refer to Table 42 .
FIFO_MODE_[2:0]	FIFO mode selection bits, setting ODR_FIFO also. Default value: 000 For the configuration setting, refer to Table 43 .

Table 42. FIFO ODR selection

ODR_FIFO_[3:0]	Configuration ⁽¹⁾
0000	FIFO disabled
0001	FIFO ODR is set to 12.5 Hz
0010	FIFO ODR is set to 26 Hz
0011	FIFO ODR is set to 52 Hz
0100	FIFO ODR is set to 104 Hz
0101	FIFO ODR is set to 208 Hz
0110	FIFO ODR is set to 416 Hz
0111	FIFO ODR is set to 833 Hz
1000	FIFO ODR is set to 1.66 kHz
1001	FIFO ODR is set to 3.33 kHz
1010	FIFO ODR is set to 6.66 kHz

1. If the device is working at an ODR slower than the one selected, FIFO ODR is limited to that ODR value. Moreover, these bits are effective if both the DATA_VALID_SEL FIFO bit of [MASTER_CONFIG \(1Ah\)](#) and the TIMER_PEDO_FIFO_DRDY bit of [FIFO_CTRL2 \(07h\)](#) are set to 0.

Table 43. FIFO mode selection

FIFO_MODE_[2:0]	Configuration mode
000	Bypass mode. FIFO disabled.
001	FIFO mode. Stops collecting data when FIFO is full.
010	Reserved
011	Continuous mode until trigger is deasserted, then FIFO mode.
100	Bypass mode until trigger is deasserted, then Continuous mode.
101	Reserved
110	Continuous mode. If the FIFO is full, the new sample overwrites the older one.
111	Reserved

10.9 DRDY_PULSE_CFG (0Bh)

DataReady configuration register (r/w).

Table 44. DRDY_PULSE_CFG register

DRDY_PULSED	0 ⁽¹⁾	0 ⁽¹⁾	0 ⁽¹⁾	0 ⁽¹⁾	0 ⁽¹⁾	0 ⁽¹⁾	INT2_WRIST_TILT
-------------	------------------	------------------	------------------	------------------	------------------	------------------	-----------------

1. This bit must be set to '0' for the correct operation of the device.

Table 45. DRDY_PULSE_CFG register description

DRDY_PULSED	Enable pulsed DataReady mode. Default value: 0 (0: DataReady latched mode. Returns to 0 only after output data has been read; 1: DataReady pulsed mode. The DataReady pulses are 75 µs long.)
INT2_WRIST_TILT	Wrist tilt interrupt on INT2 pad. Default value: 0 (0: disabled; 1: enabled)

10.10 INT1_CTRL (0Dh)

INT1 pad control register (r/w).

Each bit in this register enables a signal to be carried through INT1. The pad's output will supply the OR combination of the selected signals.

Table 46. INT1_CTRL register

INT1_STEP_DETECTOR	INT1_SIGN_MOT	INT1_FULL_FLAG	INT1_FIFO_OVR	INT1_FTH	INT1_BOOT	INT1_DRDY_G	INT1_DRDY_XL
--------------------	---------------	----------------	---------------	----------	-----------	-------------	--------------

Table 47. INT1_CTRL register description

INT1_STEP_DETECTOR	Pedometer step recognition interrupt enable on INT1 pad. Default value: 0 (0: disabled; 1: enabled)
INT1_SIGN_MOT	Significant motion interrupt enable on INT1 pad. Default value: 0 (0: disabled; 1: enabled)
INT1_FULL_FLAG	FIFO full flag interrupt enable on INT1 pad. Default value: 0 (0: disabled; 1: enabled)
INT1_FIFO_OVR	FIFO overrun interrupt on INT1 pad. Default value: 0 (0: disabled; 1: enabled)
INT1_FTH	FIFO threshold interrupt on INT1 pad. Default value: 0 (0: disabled; 1: enabled)
INT1_BOOT	Boot status available on INT1 pad. Default value: 0 (0: disabled; 1: enabled)
INT1_DRDY_G	Gyroscope Data Ready on INT1 pad. Default value: 0 (0: disabled; 1: enabled)
INT1_DRDY_XL	Accelerometer Data Ready on INT1 pad. Default value: 0 (0: disabled; 1: enabled)

10.11 INT2_CTRL (0Eh)

INT2 pad control register (r/w).

Each bit in this register enables a signal to be carried through INT2. The pad's output will supply the OR combination of the selected signals.

Table 48. INT2_CTRL register

INT2_STEP_DELTA	INT2_STEP_COUNT_OV	INT2_FULL_FLAG	INT2_FIFO_OVR	INT2_FTH	INT2_DRDY_TEMP	INT2_DRDY_G	INT2_DRDY_XL
-----------------	--------------------	----------------	---------------	----------	----------------	-------------	--------------

Table 49. INT2_CTRL register description

INT2_STEP_DELTA	Pedometer step recognition interrupt on delta time ⁽¹⁾ enable on INT2 pad. Default value: 0 (0: disabled; 1: enabled)
INT2_STEP_COUNT_OV	Step counter overflow interrupt enable on INT2 pad. Default value: 0 (0: disabled; 1: enabled)
INT2_FULL_FLAG	FIFO full flag interrupt enable on INT2 pad. Default value: 0 (0: disabled; 1: enabled)
INT2_FIFO_OVR	FIFO overrun interrupt on INT2 pad. Default value: 0 (0: disabled; 1: enabled)
INT2_FTH	FIFO threshold interrupt on INT2 pad. Default value: 0 (0: disabled; 1: enabled)
INT2_DRDY_TEMP	Temperature Data Ready on INT2 pad. Default value: 0 (0: disabled; 1: enabled)
INT2_DRDY_G	Gyroscope Data Ready on INT2 pad. Default value: 0 (0: disabled; 1: enabled)
INT2_DRDY_XL	Accelerometer Data Ready on INT2 pad. Default value: 0 (0: disabled; 1: enabled)

1. Delta time value is defined in register *STEP_COUNT_DELTA (15h)*.

10.12 WHO_AM_I (0Fh)

Who_AM_I register (r). This register is a read-only register. Its value is fixed at 6Ah.

Table 50. WHO_AM_I register

0	1	1	0	1	0	1	0
---	---	---	---	---	---	---	---

10.13 CTRL1_XL (10h)

Linear acceleration sensor control register 1 (r/w).

Table 51. CTRL1_XL register

ODR_XL3	ODR_XL2	ODR_XL1	ODR_XL0	FS_XL1	FS_XL0	LPF1_BW_SEL	BW0_XL
---------	---------	---------	---------	--------	--------	-------------	--------

Table 52. CTRL1_XL register description

ODR_XL [3:0]	Output data rate and power mode selection. Default value: 0000 (see Table 53).
FS_XL [1:0]	Accelerometer full-scale selection. Default value: 00. (00: ±2 g; 01: ±16 g; 10: ±4 g; 11: ±8 g)
LPF1_BW_SEL	Accelerometer digital LPF (LPF1) bandwidth selection. For bandwidth selection refer to CTRL8_XL (17h) .
BW0_XL	Accelerometer analog chain bandwidth selection (only for accelerometer ODR ≥ 1.67 kHz). (0: BW @ 1.5 kHz; 1: BW @ 400 Hz)

Table 53. Accelerometer ODR register setting

ODR_XL3	ODR_XL2	ODR_XL1	ODR_XL0	ODR selection [Hz] when XL_HM_MODE = 1	ODR selection [Hz] when XL_HM_MODE = 0
0	0	0	0	Power-down	Power-down
1	0	1	1	1.6 Hz (low power only)	12.5 Hz (high performance)
0	0	0	1	12.5 Hz (low power)	12.5 Hz (high performance)
0	0	1	0	26 Hz (low power)	26 Hz (high performance)
0	0	1	1	52 Hz (low power)	52 Hz (high performance)
0	1	0	0	104 Hz (normal mode)	104 Hz (high performance)
0	1	0	1	208 Hz (normal mode)	208 Hz (high performance)
0	1	1	0	416 Hz (high performance)	416 Hz (high performance)
0	1	1	1	833 Hz (high performance)	833 Hz (high performance)
1	0	0	0	1.66 kHz (high performance)	1.66 kHz (high performance)
1	0	0	1	3.33 kHz (high performance)	3.33 kHz (high performance)
1	0	1	0	6.66 kHz (high performance)	6.66 kHz (high performance)
1	1	x	x	Not allowed	Not allowed

10.14 CTRL2_G (11h)

Angular rate sensor control register 2 (r/w).

Table 54. CTRL2_G register

ODR_G3	ODR_G2	ODR_G1	ODR_G0	FS_G1	FS_G0	FS_125	0 ⁽¹⁾
--------	--------	--------	--------	-------	-------	--------	------------------

1. This bit must be set to '0' for the correct operation of the device.

Table 55. CTRL2_G register description

ODR_G [3:0]	Gyroscope output data rate selection. Default value: 0000 (Refer to Table 56)
FS_G [1:0]	Gyroscope full-scale selection. Default value: 00 (00: 250 dps; 01: 500 dps; 10: 1000 dps; 11: 2000 dps)
FS_125	Gyroscope full-scale at 125 dps. Default value: 0 (0: disabled; 1: enabled)

Table 56. Gyroscope ODR configuration setting

ODR_G3	ODR_G2	ODR_G1	ODR_G0	ODR [Hz] when G_HM_MODE = 1	ODR [Hz] when G_HM_MODE = 0
0	0	0	0	Power down	Power down
0	0	0	1	12.5 Hz (low power)	12.5 Hz (high performance)
0	0	1	0	26 Hz (low power)	26 Hz (high performance)
0	0	1	1	52 Hz (low power)	52 Hz (high performance)
0	1	0	0	104 Hz (normal mode)	104 Hz (high performance)
0	1	0	1	208 Hz (normal mode)	208 Hz (high performance)
0	1	1	0	416 Hz (high performance)	416 Hz (high performance)
0	1	1	1	833 Hz (high performance)	833 Hz (high performance)
1	0	0	0	1.66 kHz (high performance)	1.66 kHz (high performance)
1	0	0	1	3.33 kHz (high performance)	3.33 kHz (high performance)
1	0	1	0	6.66 kHz (high performance)	6.66 kHz (high performance)
1	0	1	1	Not available	Not available

10.15 CTRL3_C (12h)

Control register 3 (r/w).

Table 57. CTRL3_C register

BOOT	BDU	H_LACTIVE	PP_OD	SIM	IF_INC	BLE	SW_RESET
------	-----	-----------	-------	-----	--------	-----	----------

Table 58. CTRL3_C register description

BOOT	Reboots memory content. Default value: 0 (0: normal mode; 1: reboot memory content)
BDU	Block Data Update. Default value: 0 (0: continuous update; 1: output registers not updated until MSB and LSB have been read)
H_LACTIVE	Interrupt activation level. Default value: 0 (0: interrupt output pads active high; 1: interrupt output pads active low)
PP_OD	Push-pull/open-drain selection on INT1 and INT2 pads. Default value: 0 (0: push-pull mode; 1: open-drain mode)
SIM	SPI Serial Interface Mode selection. Default value: 0 (0: 4-wire interface; 1: 3-wire interface)
IF_INC	Register address automatically incremented during a multiple byte access with a serial interface (I ² C or SPI). Default value: 1 (0: disabled; 1: enabled)
BLE	Big/Little Endian Data selection. Default value 0 (0: data LSB @ lower address; 1: data MSB @ lower address)
SW_RESET	Software reset. Default value: 0 (0: normal mode; 1: reset device) This bit is automatically cleared.

10.16 CTRL4_C (13h)

Control register 4 (r/w).

Table 59. CTRL4_C register

DEN_XL_EN	SLEEP	INT2_on_INT1	DEN_DRDY_INT1	DRDY_MASK	I2C_disable	LPF1_SEL_G	0 ⁽¹⁾
-----------	-------	--------------	---------------	-----------	-------------	------------	------------------

Table 60. CTRL4_C register description

DEN_XL_EN	Extend DEN functionality to accelerometer sensor. Default value: 0 (0: disabled; 1: enabled)
SLEEP	Gyroscope sleep mode enable. Default value: 0 (0: disabled; 1: enabled)
INT2_on_INT1	All interrupt signals available on INT1 pad enable. Default value: 0 (0: interrupt signals divided between INT1 and INT2 pads; 1: all interrupt signals in logic or on INT1 pad)
DEN_DRDY_INT1	DEN DRDY signal on INT1 pad. Default value: 0 (0: disabled; 1: enabled)
DRDY_MASK	Configuration 1 data available enable bit. Default value: 0 (0: DA timer disabled; 1: DA timer enabled)
I2C_disable	Disable I ² C interface. Default value: 0 (0: both I ² C and SPI enabled; 1: I ² C disabled, SPI only)
LPF1_SEL_G	Enable gyroscope digital LPF1 if auxiliary SPI is disabled; the bandwidth can be selected through FTYPE [1:0] in CTRL6_C (15h) (0: disabled; 1: enabled)

10.17 CTRL5_C (14h)

Control register 5 (r/w).

Table 61. CTRL5_C register

ROUNDING2	ROUNDING1	ROUNDING0	DEN_LH	ST1_G	ST0_G	ST1_XL	ST0_XL
-----------	-----------	-----------	--------	-------	-------	--------	--------

Table 62. CTRL5_C register description

ROUNDING[2:0]	Circular burst-mode (rounding) read from output registers through the primary interface. Default value: 000 (000: no rounding; Others: refer to Table 63)
DEN_LH	DEN active level configuration. Default value: 0 (0: active low; 1: active high)
ST_G [1:0]	Angular rate sensor self-test enable. Default value: 00 (00: Self-test disabled; Other: refer to Table 64)
ST_XL [1:0]	Linear acceleration sensor self-test enable. Default value: 00 (00: Self-test disabled; Other: refer to Table 65)

Table 63. Output registers rounding pattern

ROUNDING[2:0]	Rounding pattern
000	No rounding
001	Accelerometer only
010	Gyroscope only
011	Gyroscope + accelerometer
100	Registers from <i>SENSORHUB1_REG (2Eh)</i> to <i>SENSORHUB6_REG (33h)</i> only
101	Accelerometer + registers from <i>SENSORHUB1_REG (2Eh)</i> to <i>SENSORHUB6_REG (33h)</i>
110	Gyroscope + accelerometer + registers from <i>SENSORHUB1_REG (2Eh)</i> to <i>SENSORHUB6_REG (33h)</i> and registers from <i>SENSORHUB7_REG (34h)</i> to <i>SENSORHUB12_REG (39h)</i>
111	Gyroscope + accelerometer + registers from <i>SENSORHUB1_REG (2Eh)</i> to <i>SENSORHUB6_REG (33h)</i>

Table 64. Angular rate sensor self-test mode selection

ST1_G	ST0_G	Self-test mode
0	0	Normal mode
0	1	Positive sign self-test
1	0	Not allowed
1	1	Negative sign self-test

Table 65. Linear acceleration sensor self-test mode selection

ST1_XL	ST0_XL	Self-test mode
0	0	Normal mode
0	1	Positive sign self-test
1	0	Negative sign self-test
1	1	Not allowed

10.18 CTRL6_C (15h)

Angular rate sensor control register 6 (r/w).

Table 66. CTRL6_C register

TRIG_EN	LVL1_EN	LVL2_EN	XL_HM_MODE	USR_OFF_W	0 ⁽¹⁾	FTYPE_1	FTYPE_0
---------	---------	---------	------------	-----------	------------------	---------	---------

1. This bit must be set to '0' for the correct operation of the device.

Table 67. CTRL6_C register description

TRIG_EN	DEN data edge-sensitive trigger enable. Refer to Table 68 .
LVL1_EN	DEN data level-sensitive trigger enable. Refer to Table 68 .
LVL2_EN	DEN level-sensitive latched enable. Refer to Table 68 .
XL_HM_MODE	High-performance operating mode disable for accelerometer. Default value: 0 (0: high-performance operating mode enabled; 1: high-performance operating mode disabled)
USR_OFF_W	Weight of XL user offset bits of registers X_OFS_USR (73h) , Y_OFS_USR (74h) , Z_OFS_USR (75h) 0 = 2 ⁻¹⁰ g/LSB 1 = 2 ⁻⁶ g/LSB
FTYPE[1:0]	Gyroscope's low-pass filter (LPF1) bandwidth selection Table 69 shows the selectable bandwidth values (available if auxiliary SPI is disabled).

Table 68. Trigger mode selection

TRIG_EN, LVL1_EN, LVL2_EN	Trigger mode
100	Edge-sensitive trigger mode is selected
010	Level-sensitive trigger mode is selected
011	Level-sensitive latched mode is selected
110	Level-sensitive FIFO enable mode is selected

Table 69. Gyroscope LPF1 bandwidth selection

FTYPE[1:0]	ODR = 800 Hz		ODR = 1.6 kHz		ODR = 3.3 kHz		ODR = 6.6 kHz	
	BW	Phase delay ⁽¹⁾	BW	Phase delay ⁽¹⁾	BW	Phase delay ⁽¹⁾	BW	Phase delay ⁽¹⁾
00	245 Hz	14°	315 Hz	10°	343 Hz	8°	351 Hz	7°
01	195 Hz	17°	224 Hz	12°	234 Hz	10°	237 Hz	9°
10	155 Hz	19°	168 Hz	15°	172 Hz	12°	173 Hz	11°
11	293 Hz	13°	505 Hz	8°	925 Hz	6°	937 Hz	5°

1. Phase delay @ 20 Hz

10.19 CTRL7_G (16h)

Angular rate sensor control register 7 (r/w).

Table 70. CTRL7_G register

G_HM_MODE	HP_EN_G	HPM1_G	HPM0_G	0 ⁽¹⁾	ROUNDING_STATUS	0 ⁽¹⁾	0 ⁽¹⁾
-----------	---------	--------	--------	------------------	-----------------	------------------	------------------

1. This bit must be set to '0' for the correct operation of the device.

Table 71. CTRL7_G register description

G_HM_MODE	High-performance operating mode disable for gyroscope(1). Default: 0 (0: high-performance operating mode enabled; 1: high-performance operating mode disabled)
HP_EN_G	Gyroscope digital high-pass filter enable. The filter is enabled only if the gyro is in HP mode. Default value: 0 (0: HPF disabled; 1: HPF enabled)
HPM_G[1:0]	Gyroscope digital HP filter cutoff selection. Default: 00 (00 = 16 mHz 01 = 65 mHz 10 = 260 mHz 11 = 1.04 Hz)
ROUNDING_STATUS	Source register rounding function on <i>WAKE_UP_SRC (1Bh)</i> , <i>TAP_SRC (1Ch)</i> , <i>D6D_SRC (1Dh)</i> , <i>STATUS_REG (1Eh)</i> , and <i>FUNC_SRC1 (53h)</i> registers in the primary interface. Default value: 0 (0: Rounding disabled; 1: Rounding enabled)

10.20 CTRL8_XL (17h)

Linear acceleration sensor control register 8 (r/w).

Table 72. CTRL8_XL register

LPF2_XL_EN	HPCF_XL1	HPCF_XL0	HP_REF_MODE	INPUT_COMPOSITE	HP_SLOPE_XL_EN	0 ⁽¹⁾	LOW_PASS_ON_6D
------------	----------	----------	-------------	-----------------	----------------	------------------	----------------

1. This bit must be set to '0' for the correct operation of the device.

Table 73. CTRL8_XL register description

LPF2_XL_EN	Accelerometer low-pass filter LPF2 selection. Refer to Figure 9 .
HPCF_XL[1:0]	Accelerometer LPF2 and high-pass filter configuration and cutoff setting. Refer to Table 74 .
HP_REF_MODE	Enable HP filter reference mode. Default value: 0 (0: disabled; 1: enabled ⁽¹⁾)
INPUT_COMPOSITE	Composite filter input selection. Default: 0 (0: ODR/2 low pass filtered sent to composite filter (default) 1: ODR/4 low pass filtered sent to composite filter)
HP_SLOPE_XL_EN	Accelerometer slope filter / high-pass filter selection. Refer to Figure 9 .
LOW_PASS_ON_6D	LPF2 on 6D function selection. Refer to Figure 9 .

1. When enabled, the first output data has to be discarded.

Table 74. Accelerometer bandwidth selection

HP_SLOPE_XL_EN	LPF2_XL_EN	LPF1_BW_SEL	HPCF_XL[1:0]	INPUT_COMPOSITE	Bandwidth
0 (low-pass path) ⁽¹⁾	0	0	-	-	ODR/2
		1	-	-	ODR/4
	1	-	00	1 (low noise)	ODR/50
			01		ODR/100
			10	0 (low latency)	ODR/9
11	ODR/400				
1 (high-pass path) ⁽²⁾	-	-	00	0	ODR/4
			01		ODR/100
			10		ODR/9
			11		ODR/400

1. The bandwidth column is related to LPF1 if LPF2_XL_EN = 0 or to LPF2 if LPF2_XL_EN = 1.
2. The bandwidth column is related to the slope filter if HPCF_XL[1:0] = 00 or to the HP filter if HPCF_XL[1:0] = 01/10/11.

10.21 CTRL9_XL (18h)

Linear acceleration sensor control register 9 (r/w).

Table 75. CTRL9_XL register

DEN_X	DEN_Y	DEN_Z	DEN_XL_G	0 ⁽¹⁾	SOFT_EN	0 ⁽¹⁾	0 ⁽¹⁾
-------	-------	-------	----------	------------------	---------	------------------	------------------

1. This bit must be set to '0' for the correct operation of the device.

Table 76. CTRL9_XL register description

DEN_X	DEN value stored in LSB of X-axis. Default value: 1 (0: DEN not stored in X-axis LSB; 1: DEN stored in X-axis LSB)
DEN_Y	DEN value stored in LSB of Y-axis. Default value: 1 (0: DEN not stored in Y-axis LSB; 1: DEN stored in Y-axis LSB)
DEN_Z	DEN value stored in LSB of Z-axis. Default value: 1 (0: DEN not stored in Z-axis LSB; 1: DEN stored in Z-axis LSB)
DEN_XL_G	DEN stamping sensor selection. Default value: 0 (0: DEN pin info stamped in the gyroscope axis selected by bits [7:5]; 1: DEN pin info stamped in the accelerometer axis selected by bits [7:5])
SOFT_EN	Enable soft-iron correction algorithm for magnetometer ⁽¹⁾ . Default value: 0 (0: soft-iron correction algorithm disabled; 1: soft-iron correction algorithm enabled)

1. This bit is effective if the IRON_EN bit of *MASTER_CONFIG (1Ah)* and FUNC_EN bit of *CTRL10_C (19h)* are set to 1.

10.22 CTRL10_C (19h)

Control register 10 (r/w).

Table 77. CTRL10_C register

WRIST_TILT_EN	0 ⁽¹⁾	TIMER_EN	PEDO_EN	TILT_EN	FUNC_EN	PEDO_RST_STEP	SIGN_MOTION_EN
---------------	------------------	----------	---------	---------	---------	---------------	----------------

1. This bit must be set to '0' for the correct operation of the device.

Table 78. CTRL10_C register description

WRIST_TILT_EN	Enable wrist tilt algorithm. ⁽¹⁾⁽²⁾ Default value: 0 (0: wrist tilt algorithm disabled; 1: wrist tilt algorithm enabled)
TIMER_EN	Enable timestamp count. The count is saved in <i>TIMESTAMP0_REG (40h)</i> , <i>TIMESTAMP1_REG (41h)</i> and <i>TIMESTAMP2_REG (42h)</i> . Default: 0 (0: timestamp count disabled; 1: timestamp count enabled)
PEDO_EN	Enable pedometer algorithm. ⁽²⁾ Default value: 0 (0: pedometer algorithm disabled; 1: pedometer algorithm enabled)
TILT_EN	Enable tilt calculation. ⁽²⁾
FUNC_EN	Enable embedded functionalities (pedometer, tilt, wrist tilt, significant motion detection, sensor hub and ironing). Default value: 0 (0: disable functionalities of embedded functions and accelerometer filters; 1: enable functionalities of embedded functions and accelerometer filters)
PEDO_RST_STEP	Reset pedometer step counter. Default value: 0 (0: disabled; 1: enabled)
SIGN_MOTION_EN	Enable significant motion detection function. ⁽²⁾ Default value: 0 (0: disabled; 1: enabled)

1. By default, the wrist tilt algorithm is applied to the positive X-axis.
2. This is effective if the FUNC_EN bit is set to '1'.

10.23 MASTER_CONFIG (1Ah)

Master configuration register (r/w).

Table 79. MASTER_CONFIG register

DRDY_ON_INT1	DATA_VALID_SEL_FIFO	0 ⁽¹⁾	START_CONFIG	PULL_UP_EN	PASS_THROUGH_MODE	IRON_EN	MASTER_ON
--------------	---------------------	------------------	--------------	------------	-------------------	---------	-----------

1. This bit must be set to '0' for the correct operation of the device.

Table 80. MASTER_CONFIG register description

DRDY_ON_INT1	Manage the Master DRDY signal on INT1 pad. Default: 0 (0: disable Master DRDY on INT1; 1: enable Master DRDY on INT1)
DATA_VALID_SEL_FIFO	Selection of FIFO data-valid signal. Default value: 0 (0: data-valid signal used to write data in FIFO is the XL/Gyro data-ready or step detection ⁽¹⁾ ; 1: data-valid signal used to write data in FIFO is the sensor hub data-ready)
START_CONFIG	Sensor Hub trigger signal selection. Default value: 0 (0: Sensor hub signal is the XL/Gyro data-ready; 1: Sensor hub signal external from INT2 pad.)
PULL_UP_EN	Auxiliary I ² C pull-up. Default value: 0 (0: internal pull-up on auxiliary I ² C line disabled; 1: internal pull-up on auxiliary I ² C line enabled)
PASS_THROUGH_MODE	I ² C interface pass-through. Default value: 0 (0: pass-through disabled; 1: pass-through enabled)
IRON_EN	Enable hard-iron correction algorithm for magnetometer ⁽²⁾ . Default value: 0 (0: hard-iron correction algorithm disabled; 1: hard-iron correction algorithm enabled)
MASTER_ON	Sensor hub I ² C master enable ⁽²⁾ . Default: 0 (0: master I ² C of sensor hub disabled; 1: master I ² C of sensor hub enabled)

1. If the TIMER_PEDO_FIFO_DRDY bit in *FIFO_CTRL2 (07h)* is set to 0, the trigger for writing data in FIFO is XL/Gyro data-ready, otherwise it's the step detection.

2. This is effective if the FUNC_EN bit is set to '1'.

10.24 WAKE_UP_SRC (1Bh)

Wake-up interrupt source register (r).

Table 81. WAKE_UP_SRC register

0	0	FF_IA	SLEEP_STATE_IA	WU_IA	X_WU	Y_WU	Z_WU
---	---	-------	----------------	-------	------	------	------

Table 82. WAKE_UP_SRC register description

FF_IA	Free-fall event detection status. Default: 0 (0: free-fall event not detected; 1: free-fall event detected)
SLEEP_STATE_IA	Sleep event status. Default value: 0 (0: sleep event not detected; 1: sleep event detected)
WU_IA	Wakeup event detection status. Default value: 0 (0: wakeup event not detected; 1: wakeup event detected.)
X_WU	Wakeup event detection status on X-axis. Default value: 0 (0: wakeup event on X-axis not detected; 1: wakeup event on X-axis detected)
Y_WU	Wakeup event detection status on Y-axis. Default value: 0 (0: wakeup event on Y-axis not detected; 1: wakeup event on Y-axis detected)
Z_WU	Wakeup event detection status on Z-axis. Default value: 0 (0: wakeup event on Z-axis not detected; 1: wakeup event on Z-axis detected)

10.25 TAP_SRC (1Ch)

Tap source register (r).

Table 83. TAP_SRC register

0	TAP_IA	SINGLE_TAP	DOUBLE_TAP	TAP_SIGN	X_TAP	Y_TAP	Z_TAP
---	--------	------------	------------	----------	-------	-------	-------

Table 84. TAP_SRC register description

TAP_IA	Tap event detection status. Default: 0 (0: tap event not detected; 1: tap event detected)
SINGLE_TAP	Single-tap event status. Default value: 0 (0: single tap event not detected; 1: single tap event detected)
DOUBLE_TAP	Double-tap event detection status. Default value: 0 (0: double-tap event not detected; 1: double-tap event detected.)
TAP_SIGN	Sign of acceleration detected by tap event. Default: 0 (0: positive sign of acceleration detected by tap event; 1: negative sign of acceleration detected by tap event)
X_TAP	Tap event detection status on X-axis. Default value: 0 (0: tap event on X-axis not detected; 1: tap event on X-axis detected)
Y_TAP	Tap event detection status on Y-axis. Default value: 0 (0: tap event on Y-axis not detected; 1: tap event on Y-axis detected)
Z_TAP	Tap event detection status on Z-axis. Default value: 0 (0: tap event on Z-axis not detected; 1: tap event on Z-axis detected)

10.26 D6D_SRC (1Dh)

Portrait, landscape, face-up and face-down source register (r)

Table 85. D6D_SRC register

DEN_DRDY	D6D_IA	ZH	ZL	YH	YL	XH	XL
----------	--------	----	----	----	----	----	----

Table 86. D6D_SRC register description

DEN_DRDY	DEN data-ready signal. It is set high when data output is related to the data coming from a DEN active condition. ⁽¹⁾
D6D_IA	Interrupt active for change position portrait, landscape, face-up, face-down. Default value: 0 (0: change position not detected; 1: change position detected)
ZH	Z-axis high event (over threshold). Default value: 0 (0: event not detected; 1: event (over threshold) detected)
ZL	Z-axis low event (under threshold). Default value: 0 (0: event not detected; 1: event (under threshold) detected)
YH	Y-axis high event (over threshold). Default value: 0 (0: event not detected; 1: event (over-threshold) detected)
YL	Y-axis low event (under threshold). Default value: 0 (0: event not detected; 1: event (under threshold) detected)
XH	X-axis high event (over threshold). Default value: 0 (0: event not detected; 1: event (over threshold) detected)
XL	X-axis low event (under threshold). Default value: 0 (0: event not detected; 1: event (under threshold) detected)

1. The DEN data-ready signal can be latched or pulsed depending on the value of the dataready_pulsed bit of the *DRDY_PULSE_CFG (0Bh)* register.

10.27 STATUS_REG/STATUS_SPIAux (1Eh)

The STATUS_REG register is read by the primary interface SPI/I²C (r).

Table 87. STATUS_REG register

0	0	0	0	0	TDA	GDA	XLDA
---	---	---	---	---	-----	-----	------

Table 88. STATUS_REG register description

TDA	Temperature new data available. Default: 0 (0: no set of data is available at temperature sensor output; 1: a new set of data is available at temperature sensor output)
GDA	Gyroscope new data available. Default value: 0 (0: no set of data available at gyroscope output; 1: a new set of data is available at gyroscope output)
XLDA	Accelerometer new data available. Default value: 0 (0: no set of data available at accelerometer output; 1: a new set of data is available at accelerometer output)

The STATUS_SPIAux register is read by the auxiliary SPI.

Table 89. STATUS_SPIAux register

0	0	0	0	0	GYRO_SETTLING	GDA	XLDA
---	---	---	---	---	---------------	-----	------

Table 90. STATUS_SPIAux description

GYRO_SETTLING	High when the gyroscope output is in the settling phase
GDA	Gyroscope data available (reset when one of the high parts of the output data is read)
XLDA	Accelerometer data available (reset when one of the high parts of the output data is read)

10.28 OUT_TEMP_L (20h), OUT_TEMP_H (21h)

Temperature data output register (r). L and H registers together express a 16-bit word in two's complement.

Table 91. OUT_TEMP_L register

Temp7	Temp6	Temp5	Temp4	Temp3	Temp2	Temp1	Temp0
-------	-------	-------	-------	-------	-------	-------	-------

Table 92. OUT_TEMP_H register

Temp15	Temp14	Temp13	Temp12	Temp11	Temp10	Temp9	Temp8
--------	--------	--------	--------	--------	--------	-------	-------

Table 93. OUT_TEMP register description

Temp[15:0]	Temperature sensor output data The value is expressed as two's complement sign extended on the MSB.
------------	--

10.29 OUTX_L_G (22h)

Angular rate sensor pitch axis (X) angular rate output register (r). The value is expressed as a 16-bit word in two's complement.

If this register is read by the primary interface, data are according to the full scale and ODR settings (*CTRL2_G (11h)*) of gyro user interface.

If this register is read by the auxiliary interface, data are according to the full scale and ODR (6.66 kHz) settings of the OIS gyro.

Table 94. OUTX_L_G register

D7	D6	D5	D4	D3	D2	D1	D0
----	----	----	----	----	----	----	----

Table 95. OUTX_L_G register description

D[7:0]	Pitch axis (X) angular rate value (LSbyte) D[15:0] expressed in two's complement and its value depends on the interface used: SPI1/I ² C: Gyro UI chain pitch axis output SPI2: Gyro OIS chain pitch axis output
--------	--

10.30 OUTX_H_G (23h)

Angular rate sensor pitch axis (X) angular rate output register (r). The value is expressed as a 16-bit word in two's complement.

If this register is read by the primary interface, data are according to the full scale and ODR settings (*CTRL2_G (11h)*) of the gyro user interface.

If this register is read by the auxiliary interface, data are according to the full scale and ODR (6.66 kHz) settings of the OIS gyro.

Table 96. OUTX_H_G register

D15	D14	D13	D12	D11	D10	D9	D8
-----	-----	-----	-----	-----	-----	----	----

Table 97. OUTX_H_G register description

D[15:8]	Pitch axis (X) angular rate value (MSbyte) D[15:0] expressed in two's complement and its value depends on the interface used: SPI1/I ² C: Gyro UI chain pitch axis output SPI2: Gyro OIS chain pitch axis output
---------	--

10.31 OUTY_L_G (24h)

Angular rate sensor roll axis (Y) angular rate output register (r). The value is expressed as a 16-bit word in two's complement.

If this register is read by the primary interface, data are according to the full scale and ODR settings (*CTRL2_G (11h)*) of the gyro user interface.

If this register is read by the auxiliary interface, data are according to the full scale and ODR (6.66 kHz) settings of the OIS gyro.

Table 98. OUTY_L_G register

D7	D6	D5	D4	D3	D2	D1	D0
----	----	----	----	----	----	----	----

Table 99. OUTY_L_G register description

D[7:0]	Roll axis (Y) angular rate value (LSbyte) D[15:0] expressed in two's complement and its value depends on the interface used: SPI1/I ² C: Gyro UI chain roll axis output SPI2: Gyro OIS chain roll axis output
--------	---

10.32 OUTY_H_G (25h)

Angular rate sensor roll axis (Y) angular rate output register (r). The value is expressed as a 16-bit word in two's complement.

If this register is read by the primary interface, data are according to the full scale and ODR settings (*CTRL2_G (11h)*) of the gyro user interface.

If this register is read by the auxiliary interface, data are according to the full scale and ODR (6.66 kHz) settings of the OIS gyro.

Table 100. OUTY_H_G register

D15	D14	D13	D12	D11	D10	D9	D8
-----	-----	-----	-----	-----	-----	----	----

Table 101. OUTY_H_G register description

D[15:8]	Roll axis (Y) angular rate value (MSbyte) D[15:0] expressed in two's complement and its value depends on the interface used: SPI1/I ² C: Gyro UI chain roll axis output SPI2: Gyro OIS chain roll axis output
---------	---

10.33 OUTZ_L_G (26h)

Angular rate sensor yaw axis (Z) angular rate output register (r). The value is expressed as a 16-bit word in two's complement.

If this register is read by the primary interface, data are according to the full scale and ODR settings (*CTRL2_G (11h)*) of the gyro user interface.

If this register is read by the auxiliary interface, data are according to the full scale and ODR (6.66 kHz) settings of the OIS gyro.

Table 102. OUTZ_L_G register

D7	D6	D5	D4	D3	D2	D1	D0
----	----	----	----	----	----	----	----

Table 103. OUTZ_L_G register description

D[7:0]	Yaw axis (Z) angular rate value (LSbyte) D[15:0] expressed in two's complement and its value depends on the interface used: SPI1/I ² C: Gyro UI chain yaw axis output SPI2: Gyro OIS chain yaw axis output
--------	--

10.34 OUTZ_H_G (27h)

Angular rate sensor Yaw axis (Z) angular rate output register (r). The value is expressed as a 16-bit word in two's complement.

If this register is read by the primary interface, data are according to the full scale and ODR settings (*CTRL2_G (11h)*) of the gyro user interface.

If this register is read by the auxiliary interface, data are according to the full scale and ODR (6.66 kHz) settings of the OIS gyro.

Table 104. OUTZ_H_G register

D15	D14	D13	D12	D11	D10	D9	D8
-----	-----	-----	-----	-----	-----	----	----

Table 105. OUTZ_H_G register description

D[15:8]	Yaw axis (Z) angular rate value (MSbyte) D[15:0] expressed in two's complement and its value depends on the interface used: SPI1/I ² C: Gyro UI chain yaw axis output SPI2: Gyro OIS chain yaw axis output
---------	--

10.35 OUTX_L_XL (28h)

Linear acceleration sensor X-axis output register (r). The value is expressed as a 16-bit word in two's complement.

Accelerometer data can be read also from AUX SPI @6.6 kHz.

Table 106. OUTX_L_XL register

D7	D6	D5	D4	D3	D2	D1	D0
----	----	----	----	----	----	----	----

Table 107. OUTX_L_XL register description

D[7:0]	X-axis linear acceleration value (LSbyte)
--------	---

10.36 OUTX_H_XL (29h)

Linear acceleration sensor X-axis output register (r). The value is expressed as a 16-bit word in two's complement.

Accelerometer data can be read also from AUX SPI @6.6 kHz.

Table 108. OUTX_H_XL register

D15	D14	D13	D12	D11	D10	D9	D8
-----	-----	-----	-----	-----	-----	----	----

Table 109. OUTX_H_XL register description

D[15:8]	X-axis linear acceleration value (MSbyte)
---------	---

10.37 OUTY_L_XL (2Ah)

Linear acceleration sensor Y-axis output register (r). The value is expressed as a 16-bit word in two's complement.

Accelerometer data can be read also from AUX SPI @6.6 kHz.

Table 110. OUTY_L_XL register

D7	D6	D5	D4	D3	D2	D1	D0
----	----	----	----	----	----	----	----

Table 111. OUTY_L_XL register description

D[7:0]	Y-axis linear acceleration value (LSbyte)
--------	---

10.38 OUTY_H_XL (2Bh)

Linear acceleration sensor Y-axis output register (r). The value is expressed as a 16-bit word in two's complement.

Accelerometer data can be read also from AUX SPI @6.6 kHz.

Table 112. OUTY_H_XL register

D15	D14	D13	D12	D11	D10	D9	D8
-----	-----	-----	-----	-----	-----	----	----

Table 113. OUTY_H_XL register description

D[15:8]	Y-axis linear acceleration value (MSbyte)
---------	---

10.39 OUTZ_L_XL (2Ch)

Linear acceleration sensor Z-axis output register (r). The value is expressed as a 16-bit word in two's complement.

Accelerometer data can be read also from AUX SPI @6.6 kHz.

Table 114. OUTZ_L_XL register

D7	D6	D5	D4	D3	D2	D1	D0
----	----	----	----	----	----	----	----

Table 115. OUTZ_L_XL register description

D[7:0]	Z-axis linear acceleration value (LSbyte)
--------	---

10.40 OUTZ_H_XL (2Dh)

Linear acceleration sensor Z-axis output register (r). The value is expressed as a 16-bit word in two's complement.

Accelerometer data can be read also from AUX SPI @6.6 kHz.

Table 116. OUTZ_H_XL register

D15	D14	D13	D12	D11	D10	D9	D8
-----	-----	-----	-----	-----	-----	----	----

Table 117. OUTZ_H_XL register description

D[15:8]	Z-axis linear acceleration value (MSbyte)
---------	---

10.41 SENSORHUB1_REG (2Eh)

First byte associated to external sensors. The content of the register is consistent with the SLAVE_x_CONFIG number of read operation configurations (for external sensors from x = 0 to x = 3).

Table 118. SENSORHUB1_REG register

SHub1_7	SHub1_6	SHub1_5	SHub1_4	SHub1_3	SHub1_2	SHub1_1	SHub1_0
---------	---------	---------	---------	---------	---------	---------	---------

Table 119. SENSORHUB1_REG register description

SHub1_[7:0]	First byte associated to external sensors
-------------	---

10.42 SENSORHUB2_REG (2Fh)

Second byte associated to external sensors. The content of the register is consistent with the SLAVEx_CONFIG number of read operations configurations (for external sensors from x = 0 to x = 3).

Table 120. SENSORHUB2_REG register

SHub2_7	SHub2_6	SHub2_5	SHub2_4	SHub2_3	SHub2_2	SHub2_1	SHub2_0
---------	---------	---------	---------	---------	---------	---------	---------

Table 121. SENSORHUB2_REG register description

SHub2_[7:0]	Second byte associated to external sensors
-------------	--

10.43 SENSORHUB3_REG (30h)

Third byte associated to external sensors. The content of the register is consistent with the SLAVEx_CONFIG number of read operations configurations (for external sensors from x = 0 to x = 3).

Table 122. SENSORHUB3_REG register

SHub3_7	SHub3_6	SHub3_5	SHub3_4	SHub3_3	SHub3_2	SHub3_1	SHub3_0
---------	---------	---------	---------	---------	---------	---------	---------

Table 123. SENSORHUB3_REG register description

SHub3_[7:0]	Third byte associated to external sensors
-------------	---

10.44 SENSORHUB4_REG (31h)

Fourth byte associated to external sensors. The content of the register is consistent with the SLAVEx_CONFIG number of read operation configurations (for external sensors from x = 0 to x = 3).

Table 124. SENSORHUB4_REG register

SHub4_7	SHub4_6	SHub4_5	SHub4_4	SHub4_3	SHub4_2	SHub4_1	SHub4_0
---------	---------	---------	---------	---------	---------	---------	---------

Table 125. SENSORHUB4_REG register description

SHub4_[7:0]	Fourth byte associated to external sensors
-------------	--

10.45 SENSORHUB5_REG (32h)

Fifth byte associated to external sensors. The content of the register is consistent with the SLAVEx_CONFIG number of read operation configurations (for external sensors from x = 0 to x = 3).

Table 126. SENSORHUB5_REG register

SHub5_7	SHub5_6	SHub5_5	SHub5_4	SHub5_3	SHub5_2	SHub5_1	SHub5_0
---------	---------	---------	---------	---------	---------	---------	---------

Table 127. SENSORHUB5_REG register description

SHub5_[7:0]	Fifth byte associated to external sensors
-------------	---

10.46 SENSORHUB6_REG (33h)

Sixth byte associated to external sensors. The content of the register is consistent with the SLAVEx_CONFIG number of read operation configurations (for external sensors from x = 0 to x = 3).

Table 128. SENSORHUB6_REG register

SHub6_7	SHub6_6	SHub6_5	SHub6_4	SHub6_3	SHub6_2	SHub6_1	SHub6_0
---------	---------	---------	---------	---------	---------	---------	---------

Table 129. SENSORHUB6_REG register description

SHub6_[7:0]	Sixth byte associated to external sensors
-------------	---

10.47 SENSORHUB7_REG (34h)

Seventh byte associated to external sensors. The content of the register is consistent with the SLAVEx_CONFIG number of read operation configurations (for external sensors from x = 0 to x = 3).

Table 130. SENSORHUB7_REG register

SHub7_7	SHub7_6	SHub7_5	SHub7_4	SHub7_3	SHub7_2	SHub7_1	SHub7_0
---------	---------	---------	---------	---------	---------	---------	---------

Table 131. SENSORHUB7_REG register description

SHub7_[7:0]	Seventh byte associated to external sensors
-------------	---

10.48 SENSORHUB8_REG (35h)

Eighth byte associated to external sensors. The content of the register is consistent with the SLAVEx_CONFIG number of read operation configurations (for external sensors from x = 0 to x = 3).

Table 132. SENSORHUB8_REG register

SHub8_7	SHub8_6	SHub8_5	SHub8_4	SHub8_3	SHub8_2	SHub8_1	SHub8_0
---------	---------	---------	---------	---------	---------	---------	---------

Table 133. SENSORHUB8_REG register description

SHub8_[7:0]	Eighth byte associated to external sensors
-------------	--

10.49 SENSORHUB9_REG (36h)

Ninth byte associated to external sensors. The content of the register is consistent with the SLAVEx_CONFIG number of read operation configurations (for external sensors from x = 0 to x = 3).

Table 134. SENSORHUB9_REG register

SHub9_7	SHub9_6	SHub9_5	SHub9_4	SHub9_3	SHub9_2	SHub9_1	SHub9_0
---------	---------	---------	---------	---------	---------	---------	---------

Table 135. SENSORHUB9_REG register description

SHub9_[7:0]	Ninth byte associated to external sensors
-------------	---

10.50 SENSORHUB10_REG (37h)

Tenth byte associated to external sensors. The content of the register is consistent with the SLAVEx_CONFIG number of read operation configurations (for external sensors from x = 0 to x = 3).

Table 136. SENSORHUB10_REG register

SHub10_7	SHub10_6	SHub10_5	SHub10_4	SHub10_3	SHub10_2	SHub10_1	SHub10_0
----------	----------	----------	----------	----------	----------	----------	----------

Table 137. SENSORHUB10_REG register description

SHub10_[7:0]	Tenth byte associated to external sensors
--------------	---

10.51 SENSORHUB11_REG (38h)

Eleventh byte associated to external sensors. The content of the register is consistent with the SLAVEx_CONFIG number of read operation configurations (for external sensors from x = 0 to x = 3).

Table 138. SENSORHUB11_REG register

SHub11_7	SHub11_6	SHub11_5	SHub11_4	SHub11_3	SHub11_2	SHub11_1	SHub11_0
----------	----------	----------	----------	----------	----------	----------	----------

Table 139. SENSORHUB11_REG register description

SHub11_[7:0]	Eleventh byte associated to external sensors
--------------	--

10.52 SENSORHUB12_REG (39h)

Twelfth byte associated to external sensors. The content of the register is consistent with the SLAVEx_CONFIG number of read operation configurations (for external sensors from x = 0 to x = 3).

Table 140. SENSORHUB12_REG register

SHub12_7	SHub12_6	SHub12_5	SHub12_4	SHub12_3	SHub12_2	SHub12_1	SHub12_0
----------	----------	----------	----------	----------	----------	----------	----------

Table 141. SENSORHUB12_REG register description

SHub12[7:0]	Twelfth byte associated to external sensors
-------------	---

10.53 FIFO_STATUS1 (3Ah)

FIFO status control register (r). For a proper reading of the register, it is recommended to set the BDU bit in CTRL3_C (12h) to 1.

Table 142. FIFO_STATUS1 register

DIFF_7 FIFO_7	DIFF_6 FIFO_6	DIFF_5 FIFO_5	DIFF_4 FIFO_4	DIFF_3 FIFO_3	DIFF_2 FIFO_2	DIFF_1 FIFO_1	DIFF_0 FIFO_0
------------------	------------------	------------------	------------------	------------------	------------------	------------------	------------------

Table 143. FIFO_STATUS1 register description

DIFF_FIFO_[7:0]	Number of unread words (16-bit axes) stored in FIFO ⁽¹⁾ .
-----------------	--

1. For a complete number of unread samples, consider DIFF_FIFO [10:8] in FIFO_STATUS2 (3Bh)

10.54 FIFO_STATUS2 (3Bh)

FIFO status control register (r). For a proper reading of the register, it is recommended to set the BDU bit in *CTRL3_C (12h)* to 1.

Table 144. FIFO_STATUS2 register

WaterM	OVER_RUN	FIFO_FULL_SMART	FIFO_EMPTY	0	DIFF_FIFO_10	DIFF_FIFO_9	DIFF_FIFO_8
--------	----------	-----------------	------------	---	--------------	-------------	-------------

Table 145. FIFO_STATUS2 register description

WaterM	FIFO watermark status. The watermark is set through bits FTH_[7:0] in <i>FIFO_CTRL1 (06h)</i> . Default value: 0 (0: FIFO filling is lower than watermark level ⁽¹⁾ ; 1: FIFO filling is equal to or higher than the watermark level)
OVER_RUN	FIFO overrun status. Default value: 0 (0: FIFO is not completely filled; 1: FIFO is completely filled)
FIFO_FULL_SMART	Smart FIFO full status. Default value: 0 (0: FIFO is not full; 1: FIFO will be full at the next ODR)
FIFO_EMPTY	FIFO empty bit. Default value: 0 (0: FIFO contains data; 1: FIFO is empty)
DIFF_FIFO_[10:8]	Number of unread words (16-bit axes) stored in FIFO ⁽²⁾ .

1. FIFO watermark level is set in FTH_[10:0] in *FIFO_CTRL1 (06h)* and *FIFO_CTRL2 (07h)*
2. For a complete number of unread samples, consider DIFF_FIFO [7:0] in *FIFO_STATUS1 (3Ah)*

10.55 FIFO_STATUS3 (3Ch)

FIFO status control register (r). For a proper reading of the register, it is recommended to set the BDU bit in *CTRL3_C (12h)* to 1.

Table 146. FIFO_STATUS3 register

FIFO_PATTERN_7	FIFO_PATTERN_6	FIFO_PATTERN_5	FIFO_PATTERN_4	FIFO_PATTERN_3	FIFO_PATTERN_2	FIFO_PATTERN_1	FIFO_PATTERN_0
----------------	----------------	----------------	----------------	----------------	----------------	----------------	----------------

Table 147. FIFO_STATUS3 register description

FIFO_PATTERN_[7:0]	Word of recursive pattern read at the next reading.
--------------------	---

10.56 FIFO_STATUS4 (3Dh)

FIFO status control register (r). For a proper reading of the register, it is recommended to set the BDU bit in *CTRL3_C (12h)* to 1.

Table 148. FIFO_STATUS4 register

0	0	0	0	0	0	FIFO_PATTERN_9	FIFO_PATTERN_8
---	---	---	---	---	---	----------------	----------------

Table 149. FIFO_STATUS4 register description

FIFO_PATTERN_[9:8]	Word of recursive pattern read at the next reading.
--------------------	---

10.57 FIFO_DATA_OUT_L (3Eh)

FIFO data output register (r). For a proper reading of the register, it is recommended to set the BDU bit in *CTRL3_C (12h)* to 1.

Table 150. FIFO_DATA_OUT_L register

DATA_OUT_FIFO_L_7	DATA_OUT_FIFO_L_6	DATA_OUT_FIFO_L_5	DATA_OUT_FIFO_L_4	DATA_OUT_FIFO_L_3	DATA_OUT_FIFO_L_2	DATA_OUT_FIFO_L_1	DATA_OUT_FIFO_L_0
-------------------	-------------------	-------------------	-------------------	-------------------	-------------------	-------------------	-------------------

Table 151. FIFO_DATA_OUT_L register description

DATA_OUT_FIFO_L_[7:0]	FIFO data output (first byte)
-----------------------	-------------------------------

10.58 FIFO_DATA_OUT_H (3Fh)

FIFO data output register (r). For a proper reading of the register, it is recommended to set the BDU bit in *CTRL3_C (12h)* to 1.

Table 152. FIFO_DATA_OUT_H register

DATA_OUT_FIFO_H_7	DATA_OUT_FIFO_H_6	DATA_OUT_FIFO_H_5	DATA_OUT_FIFO_H_4	DATA_OUT_FIFO_H_3	DATA_OUT_FIFO_H_2	DATA_OUT_FIFO_H_1	DATA_OUT_FIFO_H_0
-------------------	-------------------	-------------------	-------------------	-------------------	-------------------	-------------------	-------------------

Table 153. FIFO_DATA_OUT_H register description

DATA_OUT_FIFO_H_[7:0]	FIFO data output (second byte)
-----------------------	--------------------------------

10.59 TIMESTAMP0_REG (40h)

Timestamp first (least significant) byte data output register (r). The value is expressed as a 24-bit word and the bit resolution is defined by setting the value in [WAKE_UP_DUR \(5Ch\)](#).

Table 154. TIMESTAMP0_REG register

TIMESTA MP0_7	TIMESTA MP0_6	TIMESTA MP0_5	TIMESTA MP0_4	TIMESTA MP0_3	TIMESTA MP0_2	TIMESTA MP0_1	TIMESTA MP0_0
------------------	------------------	------------------	------------------	------------------	------------------	------------------	------------------

Table 155. TIMESTAMP0_REG register description

TIMESTAMP0_[7:0]	TIMESTAMP first byte data output
------------------	----------------------------------

10.60 TIMESTAMP1_REG (41h)

Timestamp second byte data output register (r). The value is expressed as a 24-bit word and the bit resolution is defined by setting value in [WAKE_UP_DUR \(5Ch\)](#).

Table 156. TIMESTAMP1_REG register

TIMESTA MP1_7	TIMESTA MP1_6	TIMESTA MP1_5	TIMESTA MP1_4	TIMESTA MP1_3	TIMESTA MP1_2	TIMESTA MP1_1	TIMESTA MP1_0
------------------	------------------	------------------	------------------	------------------	------------------	------------------	------------------

Table 157. TIMESTAMP1_REG register description

TIMESTAMP1_[7:0]	TIMESTAMP second byte data output
------------------	-----------------------------------

10.61 TIMESTAMP2_REG (42h)

Timestamp third (most significant) byte data output register (r/w). The value is expressed as a 24-bit word and the bit resolution is defined by setting the value in [WAKE_UP_DUR \(5Ch\)](#). To reset the timer, the AAh value has to be stored in this register.

Table 158. TIMESTAMP2_REG register

TIMESTA MP2_7	TIMESTA MP2_6	TIMESTA MP2_5	TIMESTA MP2_4	TIMESTA MP2_3	TIMESTA MP2_2	TIMESTA MP2_1	TIMESTA MP2_0
------------------	------------------	------------------	------------------	------------------	------------------	------------------	------------------

Table 159. TIMESTAMP2_REG register description

TIMESTAMP2_[7:0]	TIMESTAMP third byte data output
------------------	----------------------------------

10.62 STEP_TIMESTAMP_L (49h)

Step counter timestamp information register (r). When a step is detected, the value of TIMESTAMP_REG1 register is copied in STEP_TIMESTAMP_L.

Table 160. STEP_TIMESTAMP_L register

STEP_ TIMESTA MP_L_7	STEP_ TIMESTA MP_L_6	STEP_ TIMESTA MP_L_5	STEP_ TIMESTA MP_L_4	STEP_ TIMESTA MP_L_3	STEP_ TIMESTA MP_L_2	STEP_ TIMESTA MP_L_1	STEP_ TIMESTA MP_L_0
----------------------------	----------------------------	----------------------------	----------------------------	----------------------------	----------------------------	----------------------------	----------------------------

Table 161. STEP_TIMESTAMP_L register description

STEP_TIMESTAMP_L[7:0]	Timestamp of last step detected.
-----------------------	----------------------------------

10.63 STEP_TIMESTAMP_H (4Ah)

Step counter timestamp information register (r). When a step is detected, the value of TIMESTAMP_REG2 register is copied in STEP_TIMESTAMP_H.

Table 162. STEP_TIMESTAMP_H register

STEP_TIMESTAMP_H_7	STEP_TIMESTAMP_H_6	STEP_TIMESTAMP_H_5	STEP_TIMESTAMP_H_4	STEP_TIMESTAMP_H_3	STEP_TIMESTAMP_H_2	STEP_TIMESTAMP_H_1	STEP_TIMESTAMP_H_0
--------------------	--------------------	--------------------	--------------------	--------------------	--------------------	--------------------	--------------------

Table 163. STEP_TIMESTAMP_H register description

STEP_TIMESTAMP_H[7:0]	Timestamp of last step detected.
-----------------------	----------------------------------

10.64 STEP_COUNTER_L (4Bh)

Step counter output register (r).

Table 164. STEP_COUNTER_L register

STEP_COUNTER_L_7	STEP_COUNTER_L_6	STEP_COUNTER_L_5	STEP_COUNTER_L_4	STEP_COUNTER_L_3	STEP_COUNTER_L_2	STEP_COUNTER_L_1	STEP_COUNTER_L_0
------------------	------------------	------------------	------------------	------------------	------------------	------------------	------------------

Table 165. STEP_COUNTER_L register description

STEP_COUNTER_L[7:0]	Step counter output (LSbyte)
---------------------	------------------------------

10.65 STEP_COUNTER_H (4Ch)

Step counter output register (r).

Table 166. STEP_COUNTER_H register

STEP_COUNTER_H_7	STEP_COUNTER_H_6	STEP_COUNTER_H_5	STEP_COUNTER_H_4	STEP_COUNTER_H_3	STEP_COUNTER_H_2	STEP_COUNTER_H_1	STEP_COUNTER_H_0
------------------	------------------	------------------	------------------	------------------	------------------	------------------	------------------

Table 167. STEP_COUNTER_H register description

STEP_COUNTER_H[7:0]	Step counter output (MSbyte)
---------------------	------------------------------

10.66 SENSORHUB13_REG (4Dh)

Thirteenth byte associated to external sensors. The content of the register is consistent with the SLAVEx_CONFIG number of read operation configurations (for external sensors from x = 0 to x = 3).

Table 168. SENSORHUB13_REG register

SHub13_7	SHub13_6	SHub13_5	SHub13_4	SHub13_3	SHub13_2	SHub13_1	SHub13_0
----------	----------	----------	----------	----------	----------	----------	----------

Table 169. SENSORHUB13_REG register description

SHub13[7:0]	Thirteenth byte associated to external sensors
-------------	--

10.67 SENSORHUB14_REG (4Eh)

Fourteenth byte associated to external sensors. The content of the register is consistent with the SLAVEx_CONFIG number of read operation configurations (for external sensors from $x = 0$ to $x = 3$).

Table 170. SENSORHUB14_REG register

SHub14_7	SHub14_6	SHub14_5	SHub14_4	SHub14_3	SHub14_2	SHub14_1	SHub14_0
----------	----------	----------	----------	----------	----------	----------	----------

Table 171. SENSORHUB14_REG register description

SHub14_[7:0]	Fourteenth byte associated to external sensors
--------------	--

10.68 SENSORHUB15_REG (4Fh)

Fifteenth byte associated to external sensors. The content of the register is consistent with the SLAVEx_CONFIG number of read operation configurations (for external sensors from $x = 0$ to $x = 3$).

Table 172. SENSORHUB15_REG register

SHub15_7	SHub15_6	SHub15_5	SHub15_4	SHub15_3	SHub15_2	SHub15_1	SHub15_0
----------	----------	----------	----------	----------	----------	----------	----------

Table 173. SENSORHUB15_REG register description

SHub15_[7:0]	Fifteenth byte associated to external sensors
--------------	---

10.69 SENSORHUB16_REG (50h)

Sixteenth byte associated to external sensors. The content of the register is consistent with the SLAVEx_CONFIG number of read operation configurations (for external sensors from $x = 0$ to $x = 3$).

Table 174. SENSORHUB16_REG register

SHub16_7	SHub16_6	SHub16_5	SHub16_4	SHub16_3	SHub16_2	SHub16_1	SHub16_0
----------	----------	----------	----------	----------	----------	----------	----------

Table 175. SENSORHUB16_REG register description

SHub16_[7:0]	Sixteenth byte associated to external sensors
--------------	---

10.70 SENSORHUB17_REG (51h)

Seventeenth byte associated to external sensors. The content of the register is consistent with the SLAVEx_CONFIG number of read operation configurations (for external sensors from $x = 0$ to $x = 3$).

Table 176. SENSORHUB17_REG register

SHub17_7	SHub17_6	SHub17_5	SHub17_4	SHub17_3	SHub17_2	SHub17_1	SHub17_0
----------	----------	----------	----------	----------	----------	----------	----------

Table 177. SENSORHUB17_REG register description

SHub17_[7:0]	Seventeenth byte associated to external sensors
--------------	---

10.71 SENSORHUB18_REG (52h)

Eighteenth byte associated to external sensors. The content of the register is consistent with the SLAVEx_CONFIG number of read operation configurations (for external sensors from x = 0 to x = 3).

Table 178. SENSORHUB18_REG register

SHub18_7	SHub18_6	SHub18_5	SHub18_4	SHub18_3	SHub18_2	SHub18_1	SHub18_0
----------	----------	----------	----------	----------	----------	----------	----------

Table 179. SENSORHUB18_REG register description

SHub18_[7:0]	Eighteenth byte associated to external sensors
--------------	--

10.72 FUNC_SRC1 (53h)

Significant motion, tilt, step detector, hard/soft-iron and sensor hub interrupt source register (r).

Table 180. FUNC_SRC1 register

STEP_COUNT_DELTA_IA	SIGN_MOTION_IA	TILT_IA	STEP_DETECTED	STEP_OVERFLOW	HI_FAIL	SI_END_OP	SENSORHUB_END_OP
---------------------	----------------	---------	---------------	---------------	---------	-----------	------------------

Table 181. FUNC_SRC1 register description

STEP_COUNT_DELTA_IA	Pedometer step recognition on delta time status. Default value: 0 (0: no step recognized during delta time; 1: at least one step recognized during delta time)
SIGN_MOTION_IA	Significant motion event detection status. Default value: 0 (0: significant motion event not detected; 1: significant motion event detected)
TILT_IA	Tilt event detection status. Default value: 0 (0: tilt event not detected; 1: tilt event detected)
STEP_DETECTED	Step detector event detection status. Default value: 0 (0: step detector event not detected; 1: step detector event detected)
STEP_OVERFLOW	Step counter overflow status. Default value: 0 (0: step counter value < 2 ¹⁶ ; 1: step counter value reached 2 ¹⁶)
HI_FAIL	Fail in hard/soft-ironing algorithm.
SI_END_OP	Hard/soft-iron calculation status. Default value: 0 (0: Hard/soft-iron calculation not concluded; 1: Hard/soft-iron calculation concluded)
SENSORHUB_END_OP	Sensor hub communication status. Default value: 0 (0: sensor hub communication not concluded; 1: sensor hub communication concluded)

10.73 FUNC_SRC2 (54h)

Wrist tilt interrupt source register (r).

Table 182. FUNC_SRC2 register

0	SLAVE3_NACK	SLAVE2_NACK	SLAVE1_NACK	SLAVE0_NACK	0	0	WRIST_TILT_IA
---	-------------	-------------	-------------	-------------	---	---	---------------

Table 183. FUNC_SRC2 register description

SLAVE3_NACK	This bit is set to 1 if Not acknowledge occurs on slave 3 communication. Default value: 0
SLAVE2_NACK	This bit is set to 1 if Not acknowledge occurs on slave 2 communication. Default value: 0
SLAVE1_NACK	This bit is set to 1 if Not acknowledge occurs on slave 1 communication. Default value: 0
SLAVE0_NACK	This bit is set to 1 if Not acknowledge occurs on slave 0 communication. Default value: 0
WRIST_TILT_IA	Wrist tilt event detection status. Default value: 0 (0: Wrist tilt event not detected; 1: Wrist tilt event detected)

10.74 WRIST_TILT_IA (55h)

Wrist tilt interrupt source register (r).

Table 184. WRIST_TILT_IA register

WRIST_TILT_IA_Xpos	WRIST_TILT_IA_Xneg	WRIST_TILT_IA_Ypos	WRIST_TILT_IA_Yneg	WRIST_TILT_IA_Zpos	WRIST_TILT_IA_Zneg	0	0
--------------------	--------------------	--------------------	--------------------	--------------------	--------------------	---	---

Table 185. WRIST_TILT_IA register description

WRIST_TILT_IA_Xpos	Absolute Wrist Tilt event detection status on X-positive axis. Default value: 0 (0: Absolute Wrist Tilt event on X-positive axis not detected; 1: Absolute Wrist Tilt event on X-positive axis detected)
WRIST_TILT_IA_Xneg	Absolute Wrist Tilt event detection status on X-negative axis. Default value: 0 (0: Absolute Wrist Tilt event on X-negative axis not detected; 1: Absolute Wrist Tilt event on X-negative axis detected)
WRIST_TILT_IA_Ypos	Absolute Wrist Tilt event detection status on Y-positive axis. Default value: 0 (0: Absolute Wrist Tilt event on Y-positive axis not detected; 1: Absolute Wrist Tilt event on Y-positive axis detected)
WRIST_TILT_IA_Yneg	Absolute Wrist Tilt event detection status on Y-negative axis. Default value: 0 (0: Absolute Wrist Tilt event on Y-negative axis not detected; 1: Absolute Wrist Tilt event on Y-negative axis detected)
WRIST_TILT_IA_Zpos	Absolute Wrist Tilt event detection status on Z-positive axis. Default value: 0 (0: Absolute Wrist Tilt event on Z-positive axis not detected; 1: Absolute Wrist Tilt event on Z-positive axis detected)
WRIST_TILT_IA_Zneg	Absolute Wrist Tilt event detection status on Z-negative axis. Default value: 0 (0: Absolute Wrist Tilt event on Z-negative axis not detected; 1: Absolute Wrist Tilt event on Z-negative axis detected)

10.75 TAP_CFG (58h)

Enables interrupt and inactivity functions, configuration of filtering, and tap recognition functions (r/w).

Table 186. TAP_CFG register

INTERRUPTS_ENABLE	INACT_EN1	INACT_EN0	SLOPE_FDS	TAP_X_EN	TAP_Y_EN	TAP_Z_EN	LIR
-------------------	-----------	-----------	-----------	----------	----------	----------	-----

Table 187. TAP_CFG register description

INTERRUPTS_ENABLE	Enable basic interrupts (6D/4D, free-fall, wake-up, tap, inactivity). Default value: 0 (0: interrupt disabled; 1: interrupt enabled)
INACT_EN[1:0]	Enable inactivity function. Default value: 00 (00: disabled 01: sets accelerometer ODR to 12.5 Hz (low-power mode), gyro does not change; 10: sets accelerometer ODR to 12.5 Hz (low-power mode), gyro to sleep mode; 11: sets accelerometer ODR to 12.5 Hz (low-power mode), gyro to power-down mode)
SLOPE_FDS	HPF or SLOPE filter selection on wake-up and Activity/Inactivity functions. Refer to Figure 9 . Default value: 0 (0: SLOPE filter applied; 1: HPF applied)
TAP_X_EN	Enable X direction in tap recognition. Default value: 0 (0: X direction disabled; 1: X direction enabled)
TAP_Y_EN	Enable Y direction in tap recognition. Default value: 0 (0: Y direction disabled; 1: Y direction enabled)
TAP_Z_EN	Enable Z direction in tap recognition. Default value: 0 (0: Z direction disabled; 1: Z direction enabled)
LIR	Latched Interrupt. Default value: 0 (0: interrupt request not latched; 1: interrupt request latched)

10.76 TAP_THS_6D (59h)

Portrait/landscape position and tap function threshold register (r/w).

Table 188. TAP_THS_6D register

D4D_EN	SIXD_THS1	SIXD_THS0	TAP_THS4	TAP_THS3	TAP_THS2	TAP_THS1	TAP_THS0
--------	-----------	-----------	----------	----------	----------	----------	----------

Table 189. TAP_THS_6D register description

D4D_EN	4D orientation detection enable. Z-axis position detection is disabled. Default value: 0 (0: enabled; 1: disabled)
SIXD_THS[1:0]	Threshold for 4D/6D function. Default value: 00 For details, refer to Table 190 .
TAP_THS[4:0]	Threshold for tap recognition. Default value: 00000 1 Lsb corresponds to $FS_XL/2^5$

Table 190. Threshold for D4D/D6D function

SIXD_THS[1:0]	Threshold value
00	80 degrees
01	70 degrees
10	60 degrees
11	50 degrees

10.77 INT_DUR2 (5Ah)

Tap recognition function setting register (r/w).

Table 191. INT_DUR2 register

DUR3	DUR2	DUR1	DUR0	QUIET1	QUIET0	SHOCK1	SHOCK0
------	------	------	------	--------	--------	--------	--------

Table 192. INT_DUR2 register description

DUR[3:0]	Duration of maximum time gap for double tap recognition. Default: 0000 When double tap recognition is enabled, this register expresses the maximum time between two consecutive detected taps to determine a double tap event. The default value of these bits is 0000b which corresponds to $16 \cdot ODR_XL$ time. If the DUR[3:0] bits are set to a different value, 1LSB corresponds to $32 \cdot ODR_XL$ time.
QUIET[1:0]	Expected quiet time after a tap detection. Default value: 00 Quiet time is the time after the first detected tap in which there must not be any overthreshold event. The default value of these bits is 00b which corresponds to $2 \cdot ODR_XL$ time. If the QUIET[1:0] bits are set to a different value, 1LSB corresponds to $4 \cdot ODR_XL$ time.
SHOCK[1:0]	Maximum duration of overthreshold event. Default value: 00 Maximum duration is the maximum time of an overthreshold signal detection to be recognized as a tap event. The default value of these bits is 00b which corresponds to $4 \cdot ODR_XL$ time. If the SHOCK[1:0] bits are set to a different value, 1LSB corresponds to $8 \cdot ODR_XL$ time.

10.78 WAKE_UP_THS (5Bh)

Single and double-tap function threshold register (r/w).

Table 193. WAKE_UP_THS register

SINGLE_ DOUBLE_TAP	0	WK_THS5	WK_THS4	WK_THS3	WK_THS2	WK_THS1	WK_THS0
--------------------	---	---------	---------	---------	---------	---------	---------

Table 194. WAKE_UP_THS register description

SINGLE_DOUBLE_TAP	Single/double-tap event enable. Default: 0 (0: only single-tap event enabled; 1: both single and double-tap events enabled)
WK_THS[5:0]	Threshold for wakeup. Default value: 000000 1 LSB corresponds to FS_XL/2 ⁶

10.79 WAKE_UP_DUR (5Ch)

Free-fall, wakeup, timestamp and sleep mode functions duration setting register (r/w).

Table 195. WAKE_UP_DUR register

FF_DUR5	WAKE_ DUR1	WAKE_ DUR0	TIMER_ HR	SLEEP_ DUR3	SLEEP_ DUR2	SLEEP_ DUR1	SLEEP_ DUR0
---------	------------	------------	-----------	-------------	-------------	-------------	-------------

Table 196. WAKE_UP_DUR register description

FF_DUR5	Free fall duration event. Default: 0 For the complete configuration of the free-fall duration, refer to FF_DUR[4:0] in FREE_FALL (5Dh) configuration. 1 LSB = 1 ODR_time
WAKE_DUR[1:0]	Wake up duration event. Default: 00 1LSB = 1 ODR_time
TIMER_HR	Timestamp register resolution setting ⁽¹⁾ . Default value: 0 (0: 1LSB = 6.4 ms; 1: 1LSB = 25 µs)
SLEEP_DUR[3:0]	Duration to go in sleep mode. Default value: 0000 (this corresponds to 16 ODR) 1 LSB = 512 ODR

1. Configuration of this bit affects [TIMESTAMP0_REG \(40h\)](#), [TIMESTAMP1_REG \(41h\)](#), [TIMESTAMP2_REG \(42h\)](#), [STEP_TIMESTAMP_L \(49h\)](#), [STEP_TIMESTAMP_H \(4Ah\)](#), and [STEP_COUNT_DELTA \(15h\)](#) registers.

10.80 FREE_FALL (5Dh)

Free-fall function duration setting register (r/w).

Table 197. FREE_FALL register

FF_DUR4	FF_DUR3	FF_DUR2	FF_DUR1	FF_DUR0	FF_THS2	FF_THS1	FF_THS0
---------	---------	---------	---------	---------	---------	---------	---------

Table 198. FREE_FALL register description

FF_DUR[4:0]	Free-fall duration event. Default: 0 For the complete configuration of the free fall duration, refer to FF_DUR5 in WAKE_UP_DUR (5Ch) configuration
FF_THS[2:0]	Free fall threshold setting. Default: 000 For details refer to Table 199 .

Table 199. Threshold for free-fall function

FF_THS[2:0]	Threshold value
000	156 mg
001	219 mg
010	250 mg
011	312 mg
100	344 mg
101	406 mg
110	469 mg
111	500 mg

10.81 MD1_CFG (5Eh)

Functions routing on INT1 register (r/w).

Table 200. MD1_CFG register

INT1_INACT_STATE	INT1_SINGLE_TAP	INT1_WU	INT1_FF	INT1_DOUBLE_TAP	INT1_6D	INT1_TILT	INT1_TIMER
------------------	-----------------	---------	---------	-----------------	---------	-----------	------------

Table 201. MD1_CFG register description

INT1_INACT_STATE	Routing on INT1 of inactivity mode. Default: 0 (0: routing on INT1 of inactivity disabled; 1: routing on INT1 of inactivity enabled)
INT1_SINGLE_TAP	Single-tap recognition routing on INT1. Default: 0 (0: routing of single-tap event on INT1 disabled; 1: routing of single-tap event on INT1 enabled)
INT1_WU	Routing of wakeup event on INT1. Default value: 0 (0: routing of wakeup event on INT1 disabled; 1: routing of wakeup event on INT1 enabled)
INT1_FF	Routing of free-fall event on INT1. Default value: 0 (0: routing of free-fall event on INT1 disabled; 1: routing of free-fall event on INT1 enabled)
INT1_DOUBLE_TAP	Routing of tap event on INT1. Default value: 0 (0: routing of double-tap event on INT1 disabled; 1: routing of double-tap event on INT1 enabled)
INT1_6D	Routing of 6D event on INT1. Default value: 0 (0: routing of 6D event on INT1 disabled; 1: routing of 6D event on INT1 enabled)
INT1_TILT	Routing of tilt event on INT1. Default value: 0 (0: routing of tilt event on INT1 disabled; 1: routing of tilt event on INT1 enabled)
INT1_TIMER	Routing of end counter event of timer on INT1. Default value: 0 (0: routing of end counter event of timer on INT1 disabled; 1: routing of end counter event of timer event on INT1 enabled)

10.82 MD2_CFG (5Fh)

Functions routing on INT2 register (r/w).

Table 202. MD2_CFG register

INT2_INACT_STATE	INT2_SINGLE_TAP	INT2_WU	INT2_FF	INT2_DOUBLE_TAP	INT2_6D	INT2_TILT	INT2_IRON
------------------	-----------------	---------	---------	-----------------	---------	-----------	-----------

Table 203. MD2_CFG register description

INT2_INACT_STATE	Routing on INT2 of inactivity mode. Default: 0 (0: routing on INT2 of inactivity disabled; 1: routing on INT2 of inactivity enabled)
INT2_SINGLE_TAP	Single-tap recognition routing on INT2. Default: 0 (0: routing of single-tap event on INT2 disabled; 1: routing of single-tap event on INT2 enabled)
INT2_WU	Routing of wakeup event on INT2. Default value: 0 (0: routing of wakeup event on INT2 disabled; 1: routing of wake-up event on INT2 enabled)
INT2_FF	Routing of free-fall event on INT2. Default value: 0 (0: routing of free-fall event on INT2 disabled; 1: routing of free-fall event on INT2 enabled)
INT2_DOUBLE_TAP	Routing of tap event on INT2. Default value: 0 (0: routing of double-tap event on INT2 disabled; 1: routing of double-tap event on INT2 enabled)
INT2_6D	Routing of 6D event on INT2. Default value: 0 (0: routing of 6D event on INT2 disabled; 1: routing of 6D event on INT2 enabled)
INT2_TILT	Routing of tilt event on INT2. Default value: 0 (0: routing of tilt event on INT2 disabled; 1: routing of tilt event on INT2 enabled)
INT2_IRON	Routing of soft-iron/hard-iron algorithm end event on INT2. Default value: 0 (0: routing of soft-iron/hard-iron algorithm end event on INT2 disabled; 1: routing of soft-iron/hard-iron algorithm end event on INT2 enabled)

10.83 MASTER_CMD_CODE (60h)

Table 204. MASTER_CMD_CODE register

MASTER_CMD_CODE7	MASTER_CMD_CODE6	MASTER_CMD_CODE5	MASTER_CMD_CODE4	MASTER_CMD_CODE3	MASTER_CMD_CODE2	MASTER_CMD_CODE1	MASTER_CMD_CODE0
------------------	------------------	------------------	------------------	------------------	------------------	------------------	------------------

Table 205. MASTER_CMD_CODE register description

MASTER_CMD_CODE[7:0]	Master command code used for stamping for sensor sync. Default value: 0
----------------------	---

10.84 SENS_SYNC_SPI_ERROR_CODE (61h)

Table 206. SENS_SYNC_SPI_ERROR_CODE register

ERROR_CODE7	ERROR_CODE6	ERROR_CODE5	ERROR_CODE4	ERROR_CODE3	ERROR_CODE2	ERROR_CODE1	ERROR_CODE0
-------------	-------------	-------------	-------------	-------------	-------------	-------------	-------------

Table 207. SENS_SYNC_SPI_ERROR_CODE register description

ERROR_CODE[7:0]	Error code used for sensor synchronization. Default value: 0
-----------------	--

10.85 OUT_MAG_RAW_X_L (66h)

External magnetometer raw data (r).

Table 208. OUT_MAG_RAW_X_L register

D7	D6	D5	D4	D3	D2	D1	D0
----	----	----	----	----	----	----	----

Table 209. OUT_MAG_RAW_X_L register description

D[7:0]	X-axis external magnetometer value (LSbyte)
--------	---

10.86 OUT_MAG_RAW_X_H (67h)

External magnetometer raw data (r).

Table 210. OUT_MAG_RAW_X_H register

D15	D14	D13	D12	D11	D10	D9	D8
-----	-----	-----	-----	-----	-----	----	----

Table 211. OUT_MAG_RAW_X_H register description

D[15:8]	X-axis external magnetometer value (MSbyte)
---------	---

10.87 OUT_MAG_RAW_Y_L (68h)

External magnetometer raw data (r).

Table 212. OUT_MAG_RAW_Y_L register

D7	D6	D5	D4	D3	D2	D1	D0
----	----	----	----	----	----	----	----

Table 213. OUT_MAG_RAW_Y_L register description

D[7:0]	Y-axis external magnetometer value (LSbyte)
--------	---

10.88 OUT_MAG_RAW_Y_H (69h)

External magnetometer raw data (r).

Table 214. OUT_MAG_RAW_Y_H register

D15	D14	D13	D12	D11	D10	D9	D8
-----	-----	-----	-----	-----	-----	----	----

Table 215. OUT_MAG_RAW_Y_H register description

D[15:8]	Y-axis external magnetometer value (MSbyte)
---------	---

10.89 OUT_MAG_RAW_Z_L (6Ah)

External magnetometer raw data (r).

Table 216. OUT_MAG_RAW_Z_L register

D7	D6	D5	D4	D3	D2	D1	D0
----	----	----	----	----	----	----	----

Table 217. OUT_MAG_RAW_Z_L register description

D[7:0]	Z-axis external magnetometer value (LSbyte)
--------	---

10.90 OUT_MAG_RAW_Z_H (6Bh)

External magnetometer raw data (r).

Table 218. OUT_MAG_RAW_Z_H register

D15	D14	D13	D12	D11	D10	D9	D8
-----	-----	-----	-----	-----	-----	----	----

Table 219. OUT_MAG_RAW_Z_H register description

D[15:8]	Z-axis external magnetometer value (MSbyte)
---------	---

10.91 INT_OIS (6Fh)

OIS interrupt configuration register. Primary interface for read-only (r); only Aux SPI can write to this register (r/w).

Table 220. INT_OIS register

INT2_DRDY_OIS	LVL2_OIS	-	-	-	-	-	-
---------------	----------	---	---	---	---	---	---

Table 221. INT_OIS register description

INT2_DRDY_OIS	Enables the OIS chain DRDY on the INT2 pad. This setting has priority over all other INT2 settings.
LVL2_OIS	Enables level-sensitive latched mode on the OIS chain. Default value: 0

10.92 CTRL1_OIS (70h)

OIS configuration register. Primary interface for read-only (r); only Aux SPI can write to this register (r/w).

Table 222. CTRL1_OIS register

BLE_OIS	LVL1_OIS	SIM_OIS	MODE4_EN	FS1_G_OIS	FS0_G_OIS	FS_125_OIS	OIS_EN_SPI2
---------	----------	---------	----------	-----------	-----------	------------	-------------

Table 223. CTRL1_OIS register description

BLE_OIS	Big/Little Endian data selection. Default value: 0 (0: output LSbyte at lower register address; 1: output LSbyte at higher register address)
LVL1_OIS	Enables level-sensitive trigger mode on OIS chain. Default value: 0
SIM_OIS	SPI2 3- or 4-wire mode. Default value: 0 (0: 4-wire SPI2; 1: 3-wire SPI2)
MODE4_EN	Enables accelerometer OIS chain if OIS_EN_SPI2 = 1. Default value: 0 (0: disable; 1: enable)
FS[1:0]_G_OIS	Gyroscope OIS chain full-scale selection. (00: 250 dps; 01: 500 dps; 10: 1000 dps; 11: 2000 dps)
FS_125_OIS	Selects gyroscope's OIS chain full scale 125 dps (0: FS selected through bits FS[1:0]_G_OIS; 1 = 125 dps)
OIS_EN_SPI2	Enables OIS chain data processing for gyro in Mode 3 and Mode 4 (mode4_en = 1) and accelerometer data in and Mode 4 (mode4_en = 1). When the OIS chain is enabled, the OIS outputs are available through the SPI2 in registers <i>OUTX_L_G (22h)</i> through <i>OUTZ_H_G (27h)</i> and <i>STATUS_REG/STATUS_SPIAux (1Eh)</i> , and LPF1 is dedicated to this chain.

DEN mode selection can be done using the LVL1_OIS bit of register *CTRL1_OIS (70h)* and the LVL2_OIS bit of register *INT_OIS (6Fh)*.

DEN mode on the OIS path is active in the gyroscope only.

Table 224. DEN mode selection

LVL1_OIS, LVL2_OIS	DEN mode
10	Level-sensitive trigger mode is selected
11	Level-sensitive latched mode is selected

10.93 CTRL2_OIS (71h)

OIS configuration register. Primary interface for read-only (r); only Aux SPI can write to this register (r/w).

Table 225. CTRL2_OIS register

0 ⁽¹⁾	0 ⁽¹⁾	HPM1_OIS	HPM0_OIS	0 ⁽¹⁾	FTYPE_1_OIS	FTYPE_0_OIS	HP_EN_OIS
------------------	------------------	----------	----------	------------------	-------------	-------------	-----------

1. This bit must be set to '0' for the correct operation of the device.

Table 226. CTRL2_OIS register description

HPM[1:0]_OIS	Gyroscope's OIS chain digital high-pass filter cutoff selection. Default value: 00 (00: 16 mHz; 01: 65 mHz; 10: 260 mHz; 11: 1.04 Hz)
FTYPE_[1:0]_OIS	Gyroscope's digital LPF1 filter bandwidth selection <i>Table 227</i> shows cutoff and phase values obtained with all configurations
HP_EN_OIS	Enables gyroscope's OIS chain HPF. This filter is available on the OIS chain only if HP_EN_G in <i>CTRL7_G (16h)</i> is set to '0' ⁽¹⁾ .

1. HP_EN_OIS is active to select HPF on the auxiliary SPI chain only if HPF is not already used in the primary interface.

Table 227. Gyroscope OIS chain LPF1 bandwidth selection

FTYPE_[1:0]_OIS	ODR = 6.6 kHz	
	BW	Phase delay @ 20 Hz
00	351 Hz	7°
01	237 Hz	9°
10	173 Hz	11°
11	937 Hz	5°

Sampling data with frequency equal or higher to 3.3 kHz is recommended.

If data is down-sampled @ 1 kHz, it is recommended to use a cutoff @ 173 Hz.

If data is down-sampled @ 2 kHz, it is recommended to use a cutoff @ 237 Hz.

10.94 CTRL3_OIS (72h)

OIS configuration register. Primary interface for read-only (r); only Aux SPI can write to this register (r/w).

Table 228. CTRL3_OIS register

DEN_LH_OIS	FS1_XL_OIS	FS0_XL_OIS	FILTER_XL_CONF_OIS_1	FILTER_XL_CONF_OIS_0	ST1_OIS	ST0_OIS	ST_OIS_CLAMPDIS
------------	------------	------------	----------------------	----------------------	---------	---------	-----------------

Table 229. CTRL3_OIS register description

DEN_LH_OIS	Polarity of DEN signal on OIS chain (0: DEN pin is active-low; 1: DEN pin is active-high)
FS[1:0]_XL_OIS	Accelerometer OIS channel full-scale selection. Default value: 00 (00: 2 g; 01: 16 g; 10: 4 g; 11: 8 g) These two bits act only when the accelerometer UI chain is in power-down, otherwise the accelerometer FS value is selected only from the UI side (but it is readable also from the OIS side).
FILTER_XL_CONF_OIS [1:0]	Accelerometer OIS channel bandwidth selection (see Table 230)
ST[1:0]_OIS	Gyroscope OIS chain self-test selection Table 231 lists the output variation when the self-test is enabled and ST_OIS_CLAMPDIS = '1'. Default value: 00 (00: Normal mode; 01: Positive sign self-test; 10: Normal mode; 11: Negative sign self-test)
ST_OIS_CLAMPDIS	Gyro OIS chain clamp disable (0: All gyro OIS chain outputs = 8000h during self-test applied from primary interface; 1: OIS chain self-test outputs as shown in Table 231 if self-test applied from primary or auxiliary interfaces)

Table 230. Accelerometer OIS channel bandwidth selection

FILTER_XL_CONF_OIS [1:0]	ODR_UI = 0 ODR_UI ≥ 1600 Hz		ODR_UI ≤ 800 Hz	
	BW	Phase delay ⁽¹⁾	BW	Phase delay ⁽¹⁾
00	140 Hz	9.39°	128 Hz	11.5°
01	68.2 Hz	17.6°	66.5 Hz	19.7°
10	636 Hz	2.96°	329 Hz	5.08°
11	295 Hz	5.12°	222 Hz	7.23°

1. Phase delay @ 20 Hz

Table 231. Self-test nominal output variation

Full scale	Output variation [dps]
2000	400
1000	200
500	100
250	50
125	25

10.95 X_OFS_USR (73h)

Accelerometer X-axis user offset correction (r/w). The offset value set in the X_OFS_USR offset register is internally added to the acceleration value measured on the X-axis.

Table 232. X_OFS_USR register

X_OFS_USR_7	X_OFS_USR_6	X_OFS_USR_5	X_OFS_USR_4	X_OFS_USR_3	X_OFS_USR_2	X_OFS_USR_1	X_OFS_USR_0
-------------	-------------	-------------	-------------	-------------	-------------	-------------	-------------

Table 233. X_OFS_USR register description

X_OFS_USR_ [7:0]	Accelerometer X-axis user offset correction expressed in two's complement, weight depends on the CTRL6_C(4) bit. The value must be in the range [-127 127].
------------------	---

10.96 Y_OFS_USR (74h)

Accelerometer Y-axis user offset correction (r/w). The offset value set in the Y_OFS_USR offset register is internally added to the acceleration value measured on the Y-axis.

Table 234. Y_OFS_USR register

Y_OFS_USR_7	Y_OFS_USR_6	Y_OFS_USR_5	Y_OFS_USR_4	Y_OFS_USR_3	Y_OFS_USR_2	Y_OFS_USR_1	Y_OFS_USR_0
-------------	-------------	-------------	-------------	-------------	-------------	-------------	-------------

Table 235. Y_OFS_USR register description

Y_OFS_USR_ [7:0]	Accelerometer Y-axis user offset correction expressed in two's complement, weight depends on the CTRL6_C(4) bit. The value must be in the range [-127 127].
------------------	---

10.97 Z_OFS_USR (75h)

Accelerometer Z-axis user offset correction (r/w). The offset value set in the Z_OFS_USR offset register is internally subtracted from the acceleration value measured on the Z-axis.

Table 236. Z_OFS_USR register

Z_OFS_USR_7	Z_OFS_USR_6	Z_OFS_USR_5	Z_OFS_USR_4	Z_OFS_USR_3	Z_OFS_USR_2	Z_OFS_USR_1	Z_OFS_USR_0
-------------	-------------	-------------	-------------	-------------	-------------	-------------	-------------

Table 237. Z_OFS_USR register description

Z_OFS_USR_ [7:0]	Accelerometer Z-axis user offset correction expressed in two's complement, weight depends on the CTRL6_C(4) bit. The value must be in the range [-127 127].
------------------	---

11 Embedded functions register mapping

The tables given below provide a list of the first (A) and second (B) bank registers related to the embedded functions available in the device and the corresponding addresses.

The embedded functions registers of bank A are accessible when FUNC_CFG_EN is set to '1' in *FUNC_CFG_ACCESS (01h)*.

The embedded functions registers of bank B are accessible when both FUNC_CFG_EN and FUNC_CFG_EN_B set to '1' in *FUNC_CFG_ACCESS (01h)*.

Note: All modifications of the content of the embedded functions registers have to be performed with the device in power-down mode.

Table 238. Register address map - Bank A - embedded functions

Name	Type	Register address		Default	Comment
		Hex	Binary		
SLV0_ADD	r/w	02	00000010	00000000	
SLV0_SUBADD	r/w	03	00000011	00000000	
SLAVE0_CONFIG	r/w	04	00000100	00000000	
SLV1_ADD	r/w	05	00000101	00000000	
SLV1_SUBADD	r/w	06	00000110	00000000	
SLAVE1_CONFIG	r/w	07	00000111	00000000	
SLV2_ADD	r/w	08	00001000	00000000	
SLV2_SUBADD	r/w	09	00001001	00000000	
SLAVE2_CONFIG	r/w	0A	00001010	00000000	
SLV3_ADD	r/w	0B	00001011	00000000	
SLV3_SUBADD	r/w	0C	00001100	00000000	
SLAVE3_CONFIG	r/w	0D	00001101	00000000	
DATAWRITE_SRC_MODE_SUB_SLV0	r/w	0E	00001110	00000000	
CONFIG_PEDO_THS_MIN	r/w	0F	00001111	00010000	
RESERVED	-	10-12		-	Reserved
SM_THS	r/w	13	00010011	00000110	
PEDO_DEB_REG	r/w	14	00010100	01101110	
STEP_COUNT_DELTA	r/w	15	0001 0101	00000000	
MAG_SI_XX	r/w	24	00100100	00001000	
MAG_SI_XY	r/w	25	00100101	00000000	
MAG_SI_XZ	r/w	26	00100110	00000000	
MAG_SI_YX	r/w	27	00100111	00000000	
MAG_SI_YY	r/w	28	00101000	00001000	

Table 238. Register address map - Bank A - embedded functions (continued)

Name	Type	Register address		Default	Comment
		Hex	Binary		
MAG_SI_YZ	r/w	29	00101001	00000000	
MAG_SI_ZX	r/w	2A	00101010	00000000	
MAG_SI_ZY	r/w	2B	00101011	00000000	
MAG_SI_ZZ	r/w	2C	00101100	00001000	
MAG_OFFX_L	r/w	2D	00101101	00000000	
MAG_OFFX_H	r/w	2E	00101110	00000000	
MAG_OFFY_L	r/w	2F	00101111	00000000	
MAG_OFFY_H	r/w	30	00110000	00000000	
MAG_OFFZ_L	r/w	31	00110001	00000000	
MAG_OFFZ_H	r/w	32	00110010	00000000	

Table 239. Register address map - Bank B - embedded functions

Name	Type	Register address		Default	Comment
		Hex	Binary		
A_WRIST_TILT_LAT	r/w	50	01010000	00001111	
RESERVED	-	51-53			Reserved
A_WRIST_TILT_THS	r/w	54	01010100	00100000	
RESERVED	-	55-58			Reserved
A_WRIST_TILT_Mask	r/w	59	01011001	11000000	

Registers marked as *Reserved* must not be changed. Writing to those registers may cause permanent damage to the device.

The content of the registers that are loaded at boot should not be changed. They contain the factory calibration values. Their content is automatically restored when the device is powered up.

12 Embedded functions registers description - Bank A

Note: All modifications of the content of the embedded functions registers have to be performed with the device in power-down mode.

12.1 SLV0_ADD (02h)

I²C slave address of the first external sensor (Sensor1) register (r/w).

Table 240. SLV0_ADD register

Slave0_add6	Slave0_add5	Slave0_add4	Slave0_add3	Slave0_add2	Slave0_add1	Slave0_add0	rw_0
-------------	-------------	-------------	-------------	-------------	-------------	-------------	------

Table 241. SLV0_ADD register description

Slave0_add[6:0]	I ² C slave address of Sensor1 that can be read by sensor hub. Default value: 0000000
rw_0	Read/write operation on Sensor1. Default value: 0 (0: write operation; 1: read operation)

12.2 SLV0_SUBADD (03h)

Address of register on the first external sensor (Sensor1) register (r/w).

Table 242. SLV0_SUBADD register

Slave0_reg7	Slave0_reg6	Slave0_reg5	Slave0_reg4	Slave0_reg3	Slave0_reg2	Slave0_reg1	Slave0_reg0
-------------	-------------	-------------	-------------	-------------	-------------	-------------	-------------

Table 243. SLV0_SUBADD register description

Slave0_reg[7:0]	Address of register on Sensor1 that has to be read/write according to the rw_0 bit value in <i>SLV0_ADD (02h)</i> . Default value: 00000000
-----------------	---

12.3 SLAVE0_CONFIG (04h)

First external sensor (Sensor1) configuration and sensor hub settings register (r/w).

Table 244. SLAVE0_CONFIG register

Slave0_rate1	Slave0_rate0	Aux_sens_on1	Aux_sens_on0	Src_mode	Slave0_numop2	Slave0_numop1	Slave0_numop0
--------------	--------------	--------------	--------------	----------	---------------	---------------	---------------

Table 245. SLAVE0_CONFIG register description

Slave0_rate[1:0]	Decimation of read operation on Sensor1 starting from the sensor hub trigger. Default value: 00 (00: no decimation 01: update every 2 samples 10: update every 4 samples 11: update every 8 samples)
Aux_sens_on[1:0]	Number of external sensors to be read by sensor hub. Default value: 00 (00: one sensor 01: two sensors 10: three sensors 11: four sensors)
Src_mode	Source mode conditioned read ⁽¹⁾ . Default value: 0 (0: source mode read disabled; 1: source mode read enabled)
Slave0_numop[2:0]	Number of read operations on Sensor1.

1. Read conditioned by the content of the register at address specified in the [DATAWRITE_SRC_MODE_SUB_SLV0 \(0Eh\)](#) register. If the content is non-zero, the operation continues with the reading of the address specified in the [SLV0_SUBADD \(03h\)](#) register, else the operation is interrupted.

12.4 SLV1_ADD (05h)

I²C slave address of the second external sensor (Sensor2) register (r/w).

Table 246. SLV1_ADD register

Slave1_add6	Slave1_add5	Slave1_add4	Slave1_add3	Slave1_add2	Slave1_add1	Slave1_add0	r_1
-------------	-------------	-------------	-------------	-------------	-------------	-------------	-----

Table 247. SLV1_ADD register description

Slave1_add[6:0]	I ² C slave address of Sensor2 that can be read by sensor hub. Default value: 0000000
r_1	Read operation on Sensor2 enable. Default value: 0 (0: read operation disabled; 1: read operation enabled)

12.5 SLV1_SUBADD (06h)

Address of register on the second external sensor (Sensor2) register (r/w).

Table 248. SLV1_SUBADD register

Slave1_reg7	Slave1_reg6	Slave1_reg5	Slave1_reg4	Slave1_reg3	Slave1_reg2	Slave1_reg1	Slave1_reg0
-------------	-------------	-------------	-------------	-------------	-------------	-------------	-------------

Table 249. SLV1_SUBADD register description

Slave1_reg[7:0]	Address of register on Sensor2 that has to be read according to the r_1 bit value in SLV1_ADD (05h) . Default value: 00000000
-----------------	---

12.6 SLAVE1_CONFIG (07h)

Second external sensor (Sensor2) configuration register (r/w).

Table 250. SLAVE1_CONFIG register

Slave1_rate1	Slave1_rate0	write_once	0 ⁽¹⁾	0 ⁽¹⁾	Slave1_numop2	Slave1_numop1	Slave1_numop0
--------------	--------------	------------	------------------	------------------	---------------	---------------	---------------

1. This bit must be set to '0' for the correct operation of the device.

Table 251. SLAVE1_CONFIG register description

Slave1_rate[1:0]	Decimation of read operation on Sensor2 starting from the sensor hub trigger. Default value: 00 (00: no decimation 01: update every 2 samples 10: update every 4 samples 11: update every 8 samples)
write_once	Slave 0 write operation is performed only at the first sensor hub cycle. ⁽¹⁾ Default value: 0 0: write operation for each sensor hub cycle 1: write operation only for the first sensor hub cycle
Slave1_numop[2:0]	Number of read operations on Sensor2.

1. This is effective if the Aux_sens_on[1:0] field in *SLAVE0_CONFIG (04h)* is set to a value other than 00.

12.7 SLV2_ADD (08h)

I²C slave address of the third external sensor (Sensor3) register (r/w).

Table 252. SLV2_ADD register

Slave2_add6	Slave2_add5	Slave2_add4	Slave2_add3	Slave2_add2	Slave2_add1	Slave2_add0	r_2
-------------	-------------	-------------	-------------	-------------	-------------	-------------	-----

Table 253. SLV2_ADD register description

Slave2_add[6:0]	I ² C slave address of Sensor3 that can be read by sensor hub. Default value: 0000000
r_2	Read operation on Sensor3 enable. Default value: 0 (0: read operation disabled; 1: read operation enabled)

12.8 SLV2_SUBADD (09h)

Address of register on the third external sensor (Sensor3) register (r/w).

Table 254. SLV2_SUBADD register

Slave2_reg7	Slave2_reg6	Slave2_reg5	Slave2_reg4	Slave2_reg3	Slave2_reg2	Slave2_reg1	Slave2_reg0
-------------	-------------	-------------	-------------	-------------	-------------	-------------	-------------

Table 255. SLV2_SUBADD register description

Slave2_reg[7:0]	Address of register on Sensor3 that has to be read according to the r_2 bit value in <i>SLV2_ADD (08h)</i> . Default value: 00000000
-----------------	--

12.9 SLAVE2_CONFIG (0Ah)

Third external sensor (Sensor3) configuration register (r/w).

Table 256. SLAVE2_CONFIG register

Slave2_rate1	Slave2_rate0	0 ⁽¹⁾	0 ⁽¹⁾	0 ⁽¹⁾	Slave2_numop2	Slave2_numop1	Slave2_numop0
--------------	--------------	------------------	------------------	------------------	---------------	---------------	---------------

1. This bit must be set to '0' for the correct operation of the device.

Table 257. SLAVE2_CONFIG register description

Slave2_rate[1:0]	Decimation of read operation on Sensor3 starting from the sensor hub trigger. Default value: 00 (00: no decimation 01: update every 2 samples 10: update every 4 samples 11: update every 8 samples)
Slave2_numop[2:0]	Number of read operations on Sensor3.

12.10 SLV3_ADD (0Bh)

I²C slave address of the fourth external sensor (Sensor4) register (r/w).

Table 258. SLV3_ADD register

Slave3_add6	Slave3_add5	Slave3_add4	Slave3_add3	Slave3_add2	Slave3_add1	Slave3_add0	r_3
-------------	-------------	-------------	-------------	-------------	-------------	-------------	-----

Table 259. SLV3_ADD register description

Slave3_add[6:0]	I ² C slave address of Sensor4 that can be read by the sensor hub. Default value: 0000000
r_3	Read operation on Sensor4 enable. Default value: 0 (0: read operation disabled; 1: read operation enabled)

12.11 SLV3_SUBADD (0Ch)

Address of register on the fourth external sensor (Sensor4) register (r/w).

Table 260. SLV3_SUBADD register

Slave3_reg7	Slave3_reg6	Slave3_reg5	Slave3_reg4	Slave3_reg3	Slave3_reg2	Slave3_reg1	Slave3_reg0
-------------	-------------	-------------	-------------	-------------	-------------	-------------	-------------

Table 261. SLV3_SUBADD register description

Slave3_reg[7:0]	Address of register on Sensor4 that has to be read according to the r_3 bit value in <i>SLV3_ADD (0Bh)</i> . Default value: 00000000
-----------------	--

12.12 SLAVE3_CONFIG (0Dh)

Fourth external sensor (Sensor4) configuration register (r/w).

Table 262. SLAVE3_CONFIG register

Slave3_rate1	Slave3_rate0	0 ⁽¹⁾	0 ⁽¹⁾	0 ⁽¹⁾	Slave3_numop2	Slave3_numop1	Slave3_numop0
--------------	--------------	------------------	------------------	------------------	---------------	---------------	---------------

1. This bit must be set to '0' for the correct operation of the device.

Table 263. SLAVE3_CONFIG register description

Slave3_rate[1:0]	Decimation of read operation on Sensor4 starting from the sensor hub trigger. Default value: 00 (00: no decimation 01: update every 2 samples 10: update every 4 samples 11: update every 8 samples)
Slave3_numop[2:0]	Number of read operations on Sensor4.

12.13 DATAWRITE_SRC_MODE_SUB_SLV0 (0Eh)

Data to be written into the slave device register (r/w).

Table 264. DATAWRITE_SRC_MODE_SUB_SLV0 register

Slave_dataw7	Slave_dataw6	Slave_dataw5	Slave_dataw4	Slave_dataw3	Slave_dataw2	Slave_dataw1	Slave_dataw0
--------------	--------------	--------------	--------------	--------------	--------------	--------------	--------------

Table 265. DATAWRITE_SRC_MODE_SUB_SLV0 register description

Slave_dataw[7:0]	Data to be written into the slave device according to the rw_0 bit in SLV0_ADD (02h) register or address to be read in source mode. Default value: 00000000
------------------	--

12.14 CONFIG_PEDO_THS_MIN (0Fh)

Table 266. CONFIG_PEDO_THS_MIN register

PEDO_FS	0	0	ths_min_4	ths_min_3	ths_min_2	ths_min_1	ths_min_0
---------	---	---	-----------	-----------	-----------	-----------	-----------

Table 267. CONFIG_PEDO_THS_MIN register description

PEDO_FS	Pedometer data elaboration at 4 g. (0: elaboration of 2 g data; 1: elaboration of 4 g data)
ths_min_[4:0]	Minimum threshold to detect a peak. Default is 10h.

12.15 SM_THS (13h)

Significant motion configuration register (r/w).

Table 268. SM_THS register

SM_THS_ 7	SM_THS_ 6	SM_THS_ 5	SM_THS_ 4	SM_THS_ 3	SM_THS_ 2	SM_THS_ 1	SM_THS_ 0
--------------	--------------	--------------	--------------	--------------	--------------	--------------	--------------

Table 269. SM_THS register description

SM_THS[7:0]	Significant motion threshold. Default value: 00000110
-------------	---

12.16 PEDO_DEB_REG (14h)

Table 270. PEDO_DEB_REG register

DEB_ TIME4	DEB_ TIME3	DEB_ TIME2	DEB_ TIME1	DEB_ TIME0	DEB_ STEP2	DEB_ STEP1	DEB_ STEP0
---------------	---------------	---------------	---------------	---------------	---------------	---------------	---------------

Table 271. PEDO_DEB_REG register description

DEB_TIME[4:0]	Debounce time. If the time between two consecutive steps is greater than DEB_TIME*80ms, the debouncer is reactivated. Default value: 01101
DEB_STEP[2:0]	Debounce threshold. Minimum number of steps to increment step counter (debounce). Default value: 110

12.17 STEP_COUNT_DELTA (15h)

Time period register for step detection on delta time (r/w).

Table 272. STEP_COUNT_DELTA register

SC_ DELTA_7	SC_ DELTA_6	SC_ DELTA_5	SC_ DELTA_4	SC_ DELTA_3	SC_ DELTA_2	SC_ DELTA_1	SC_ DELTA_0
----------------	----------------	----------------	----------------	----------------	----------------	----------------	----------------

Table 273. STEP_COUNT_DELTA register description

SC_DELTA[7:0]	Time period value ⁽¹⁾ (1LSB = 1.6384 s)
---------------	--

- This value is effective if the TIMER_EN bit of *CTRL10_C (19h)* is set to 1 and the TIMER_HR bit of *WAKE_UP_DUR (5Ch)* is set to 0.

12.18 MAG_SI_XX (24h)

Soft-iron matrix correction register (r/w).

Table 274. MAG_SI_XX register

MAG_SI_XX_7	MAG_SI_XX_6	MAG_SI_XX_5	MAG_SI_XX_4	MAG_SI_XX_3	MAG_SI_XX_2	MAG_SI_XX_1	MAG_SI_XX_0
-------------	-------------	-------------	-------------	-------------	-------------	-------------	-------------

Table 275. MAG_SI_XX register description

MAG_SI_XX_[7:0]	Soft-iron correction row1 col1 coefficient ⁽¹⁾ . Default value: 00001000
-----------------	---

1. Value is expressed in sign-module format.

12.19 MAG_SI_XY (25h)

Soft-iron matrix correction register (r/w).

Table 276. MAG_SI_XY register

MAG_SI_XY_7	MAG_SI_XY_6	MAG_SI_XY_5	MAG_SI_XY_4	MAG_SI_XY_3	MAG_SI_XY_2	MAG_SI_XY_1	MAG_SI_XY_0
-------------	-------------	-------------	-------------	-------------	-------------	-------------	-------------

Table 277. MAG_SI_XY register description

MAG_SI_XY_[7:0]	Soft-iron correction row1 col2 coefficient ⁽¹⁾ . Default value: 00000000
-----------------	---

1. Value is expressed in sign-module format.

12.20 MAG_SI_XZ (26h)

Soft-iron matrix correction register (r/w).

Table 278. MAG_SI_XZ register

MAG_SI_XZ_7	MAG_SI_XZ_6	MAG_SI_XZ_5	MAG_SI_XZ_4	MAG_SI_XZ_3	MAG_SI_XZ_2	MAG_SI_XZ_1	MAG_SI_XZ_0
-------------	-------------	-------------	-------------	-------------	-------------	-------------	-------------

Table 279. MAG_SI_XZ register description

MAG_SI_XZ_[7:0]	Soft-iron correction row1 col3 coefficient ⁽¹⁾ . Default value: 00000000
-----------------	---

1. Value is expressed in sign-module format.

12.21 MAG_SI_YX (27h)

Soft-iron matrix correction register (r/w).

Table 280. MAG_SI_YX register

MAG_SI_YX_7	MAG_SI_YX_6	MAG_SI_YX_5	MAG_SI_YX_4	MAG_SI_YX_3	MAG_SI_YX_2	MAG_SI_YX_1	MAG_SI_YX_0
-------------	-------------	-------------	-------------	-------------	-------------	-------------	-------------

Table 281. MAG_SI_YX register description

MAG_SI_YX_[7:0]	Soft-iron correction row2 col1 coefficient ⁽¹⁾ . Default value: 00000000
-----------------	---

1. Value is expressed in sign-module format.

12.22 MAG_SI_YY (28h)

Soft-iron matrix correction register (r/w).

Table 282. MAG_SI_YY register

MAG_SI_YY_7	MAG_SI_YY_6	MAG_SI_YY_5	MAG_SI_YY_4	MAG_SI_YY_3	MAG_SI_YY_2	MAG_SI_YY_1	MAG_SI_YY_0
-------------	-------------	-------------	-------------	-------------	-------------	-------------	-------------

Table 283. MAG_SI_YY register description

MAG_SI_YY_[7:0]	Soft-iron correction row2 col2 coefficient ⁽¹⁾ . Default value: 00001000
-----------------	---

1. Value is expressed in sign-module format.

12.23 MAG_SI_YZ (29h)

Soft-iron matrix correction register (r/w).

Table 284. MAG_SI_YZ register

MAG_SI_YZ_7	MAG_SI_YZ_6	MAG_SI_YZ_5	MAG_SI_YZ_4	MAG_SI_YZ_3	MAG_SI_YZ_2	MAG_SI_YZ_1	MAG_SI_YZ_0
-------------	-------------	-------------	-------------	-------------	-------------	-------------	-------------

Table 285. MAG_SI_YZ register description

MAG_SI_YZ_[7:0]	Soft-iron correction row2 col3 coefficient ⁽¹⁾ . Default value: 00000000
-----------------	---

1. Value is expressed in sign-module format.

12.24 MAG_SI_ZX (2Ah)

Soft-iron matrix correction register (r/w).

Table 286. MAG_SI_ZX register

MAG_SI_ZX_7	MAG_SI_ZX_6	MAG_SI_ZX_5	MAG_SI_ZX_4	MAG_SI_ZX_3	MAG_SI_ZX_2	MAG_SI_ZX_1	MAG_SI_ZX_0
-------------	-------------	-------------	-------------	-------------	-------------	-------------	-------------

Table 287. MAG_SI_ZX register description

MAG_SI_ZX_[7:0]	Soft-iron correction row3 col1 coefficient ⁽¹⁾ . Default value: 00000000
-----------------	---

1. Value is expressed in sign-module format.

12.25 MAG_SI_ZY (2Bh)

Soft-iron matrix correction register (r/w).

Table 288. MAG_SI_ZY register

MAG_SI_ZY_7	MAG_SI_ZY_6	MAG_SI_ZY_5	MAG_SI_ZY_4	MAG_SI_ZY_3	MAG_SI_ZY_2	MAG_SI_ZY_1	MAG_SI_ZY_0
-------------	-------------	-------------	-------------	-------------	-------------	-------------	-------------

Table 289. MAG_SI_ZY register description

MAG_SI_ZY_[7:0]	Soft-iron correction row3 col2 coefficient ⁽¹⁾ . Default value: 00000000
-----------------	---

1. Value is expressed in sign-module format.

12.26 MAG_SI_ZZ (2Ch)

Soft-iron matrix correction register (r/w).

Table 290. MAG_SI_ZZ register

MAG_SI_ZZ_7	MAG_SI_ZZ_6	MAG_SI_ZZ_5	MAG_SI_ZZ_4	MAG_SI_ZZ_3	MAG_SI_ZZ_2	MAG_SI_ZZ_1	MAG_SI_ZZ_0
-------------	-------------	-------------	-------------	-------------	-------------	-------------	-------------

Table 291. MAG_SI_ZZ register description

MAG_SI_ZZ[7:0]	Soft-iron correction row3 col3 coefficient ⁽¹⁾ . Default value: 00001000
----------------	---

1. Value is expressed in sign-module format.

12.27 MAG_OFFX_L (2Dh)

Offset for X-axis hard-iron compensation register (r/w). The value is expressed as a 16-bit word in two's complement.

Table 292. MAG_OFFX_L register

MAG_OFF_X_L_7	MAG_OFF_X_L_6	MAG_OFF_X_L_5	MAG_OFF_X_L_4	MAG_OFF_X_L_3	MAG_OFF_X_L_2	MAG_OFF_X_L_1	MAG_OFF_X_L_0
---------------	---------------	---------------	---------------	---------------	---------------	---------------	---------------

Table 293. MAG_OFFX_L register description

MAG_OFFX_L[7:0]	Offset for X-axis hard-iron compensation. Default value: 00000000
-----------------	---

12.28 MAG_OFFX_H (2Eh)

Offset for X-axis hard-iron compensation register (r/w). The value is expressed as a 16-bit word in two's complement.

Table 294. MAG_OFFX_H register

MAG_OFF_X_H_7	MAG_OFF_X_H_6	MAG_OFF_X_H_5	MAG_OFF_X_H_4	MAG_OFF_X_H_3	MAG_OFF_X_H_2	MAG_OFF_X_H_1	MAG_OFF_X_H_0
---------------	---------------	---------------	---------------	---------------	---------------	---------------	---------------

Table 295. MAG_OFFX_H register description

MAG_OFFX_H[7:0]	Offset for X-axis hard-iron compensation. Default value: 00000000
-----------------	---

12.29 MAG_OFFY_L (2Fh)

Offset for Y-axis hard-iron compensation register (r/w). The value is expressed as a 16-bit word in two's complement.

Table 296. MAG_OFFY_L register

MAG_OFF_Y_L_7	MAG_OFF_Y_L_6	MAG_OFF_Y_L_5	MAG_OFF_Y_L_4	MAG_OFF_Y_L_3	MAG_OFF_Y_L_2	MAG_OFF_Y_L_1	MAG_OFF_Y_L_0
---------------	---------------	---------------	---------------	---------------	---------------	---------------	---------------

Table 297. MAG_OFFY_L register description

MAG_OFFY_L[7:0]	Offset for Y-axis hard-iron compensation. Default value: 00000000
-----------------	---

12.30 MAG_OFFY_H (30h)

Offset for Y-axis hard-iron compensation register (r/w). The value is expressed as a 16-bit word in two's complement.

Table 298. MAG_OFFY_H register

MAG_OFF Y_H_7	MAG_OFF Y_H_6	MAG_OFF Y_H_5	MAG_OFF Y_H_4	MAG_OFF Y_H_3	MAG_OFF Y_H_2	MAG_OFF Y_H_1	MAG_OFF Y_H_0
------------------	------------------	------------------	------------------	------------------	------------------	------------------	------------------

Table 299. MAG_OFFY_H register description

MAG_OFFY_H[7:0]	Offset for Y-axis hard-iron compensation. Default value: 00000000
-----------------	---

12.31 MAG_OFFZ_L (31h)

Offset for Z-axis hard-iron compensation register (r/w). The value is expressed as a 16-bit word in two's complement.

Table 300. MAG_OFFZ_L register

MAG_OFF Z_L_7	MAG_OFF Z_L_6	MAG_OFF Z_L_5	MAG_OFF Z_L_4	MAG_OFF Z_L_3	MAG_OFF Z_L_2	MAG_OFF Z_L_1	MAG_OFF Z_L_0
------------------	------------------	------------------	------------------	------------------	------------------	------------------	------------------

Table 301. MAG_OFFZ_L register description

MAG_OFFZ_L[7:0]	Offset for Z-axis hard-iron compensation. Default value: 00000000
-----------------	---

12.32 MAG_OFFZ_H (32h)

Offset for Z-axis hard-iron compensation register (r/w). The value is expressed as a 16-bit word in two's complement.

Table 302. MAG_OFFZ_H register

MAG_OFF Z_H_7	MAG_OFF Z_H_6	MAG_OFF Z_H_5	MAG_OFF Z_H_4	MAG_OFF Z_H_3	MAG_OFF Z_H_2	MAG_OFF Z_H_1	MAG_OFF Z_H_0
------------------	------------------	------------------	------------------	------------------	------------------	------------------	------------------

Table 303. MAG_OFFZ_H register description

MAG_OFFZ_H[7:0]	Offset for Z-axis hard-iron compensation. Default value: 00000000
-----------------	---

13 Embedded functions registers description - Bank B

13.1 A_WRIST_TILT_LAT (50h)

Absolute Wrist Tilt latency register (r/w).

Table 304. A_WRIST_TILT_LAT register

WRIST_TILT_TIMER7	WRIST_TILT_TIMER6	WRIST_TILT_TIMER5	WRIST_TILT_TIMER4	WRIST_TILT_TIMER3	WRIST_TILT_TIMER2	WRIST_TILT_TIMER1	WRIST_TILT_TIMER0
-------------------	-------------------	-------------------	-------------------	-------------------	-------------------	-------------------	-------------------

Table 305. A_WRIST_TILT_LAT register description

WRIST_TILT_TIMER[7:0]	Absolute wrist tilt latency parameters. 1 LSB = 40 ms. Default value: 0Fh (600 ms)
-----------------------	---

13.2 A_WRIST_TILT_THS (54h)

Absolute Wrist Tilt threshold register (r/w).

Table 306. A_WRIST_TILT_THS register

WRIST_TILT_THS7	WRIST_TILT_THS6	WRIST_TILT_THS5	WRIST_TILT_THS4	WRIST_TILT_THS3	WRIST_TILT_THS2	WRIST_TILT_THS1	WRIST_TILT_THS0
-----------------	-----------------	-----------------	-----------------	-----------------	-----------------	-----------------	-----------------

Table 307. A_WRIST_TILT_THS register description

WRIST_TILT_THS[7:0]	Absolute wrist tilt threshold parameters. 1 LSB = 15.625 mg. Default value: 20h (500 mg)
---------------------	---

13.3 A_WRIST_TILT_Mask (59h)

Absolute Wrist Tilt mask register (r/w).

Table 308. A_WRIST_TILT_Mask register

WRIST_TILT_MASK_Xpos	WRIST_TILT_MASK_Xneg	WRIST_TILT_MASK_Ypos	WRIST_TILT_MASK_Yneg	WRIST_TILT_MASK_Zpos	WRIST_TILT_MASK_Zneg	0	0
----------------------	----------------------	----------------------	----------------------	----------------------	----------------------	---	---

Table 309. A_WRIST_TILT_Mask register description

WRIST_TILT_MASK_Xpos	Absolute wrist tilt positive X-axis enable. Default value: 1 (0: disable; 1: enable)
WRIST_TILT_MASK_Xneg	Absolute wrist tilt negative X-axis enable. Default value: 1 (0: disable; 1: enable)
WRIST_TILT_MASK_Ypos	Absolute wrist tilt positive Y-axis enable. Default value: 0 (0: disable; 1: enable)
WRIST_TILT_MASK_Yneg	Absolute wrist tilt negative Y-axis enable. Default value: 0 (0: disable; 1: enable)
WRIST_TILT_MASK_Zpos	Absolute wrist tilt positive Z-axis enable. Default value: 0 (0: disable; 1: enable)
WRIST_TILT_MASK_Zneg	Absolute wrist tilt negative Z-axis enable. Default value: 0 (0: disable; 1: enable)

14 Soldering information

The LGA package is compliant with the ECOPACK®, RoHS and "Green" standard. It is qualified for soldering heat resistance according to JEDEC J-STD-020.

Land pattern and soldering recommendations are available at www.st.com/mems.

15 Package information

In order to meet environmental requirements, ST offers these devices in different grades of ECOPACK® packages, depending on their level of environmental compliance. ECOPACK® specifications, grade definitions and product status are available at: www.st.com. ECOPACK is an ST trademark.

15.1 LGA-14L package information

Figure 23. LGA-14L 2.5x3x0.86 mm package outline and mechanical data

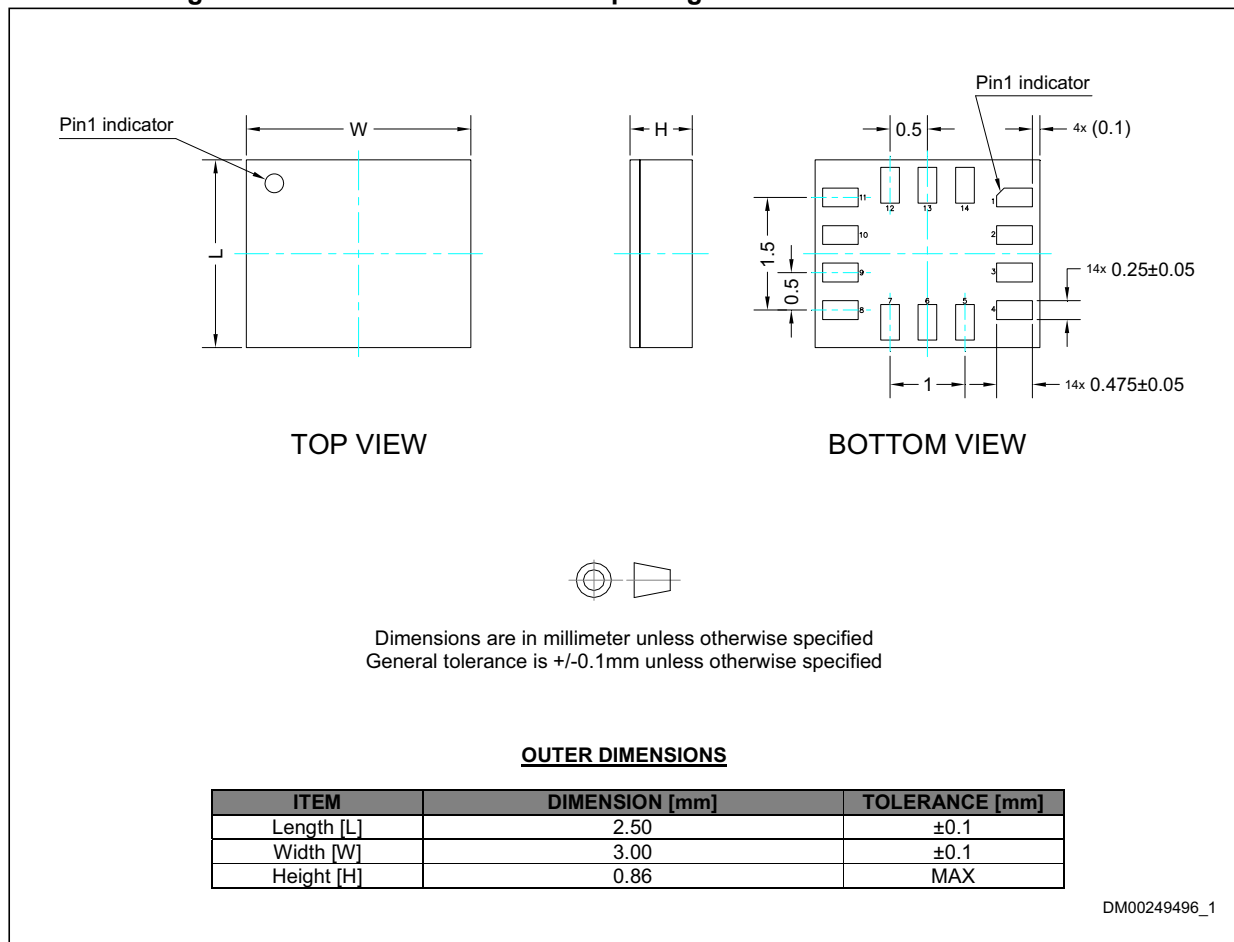

15.2 LGA-14 package information

Figure 24. Carrier tape information for LGA-14 package

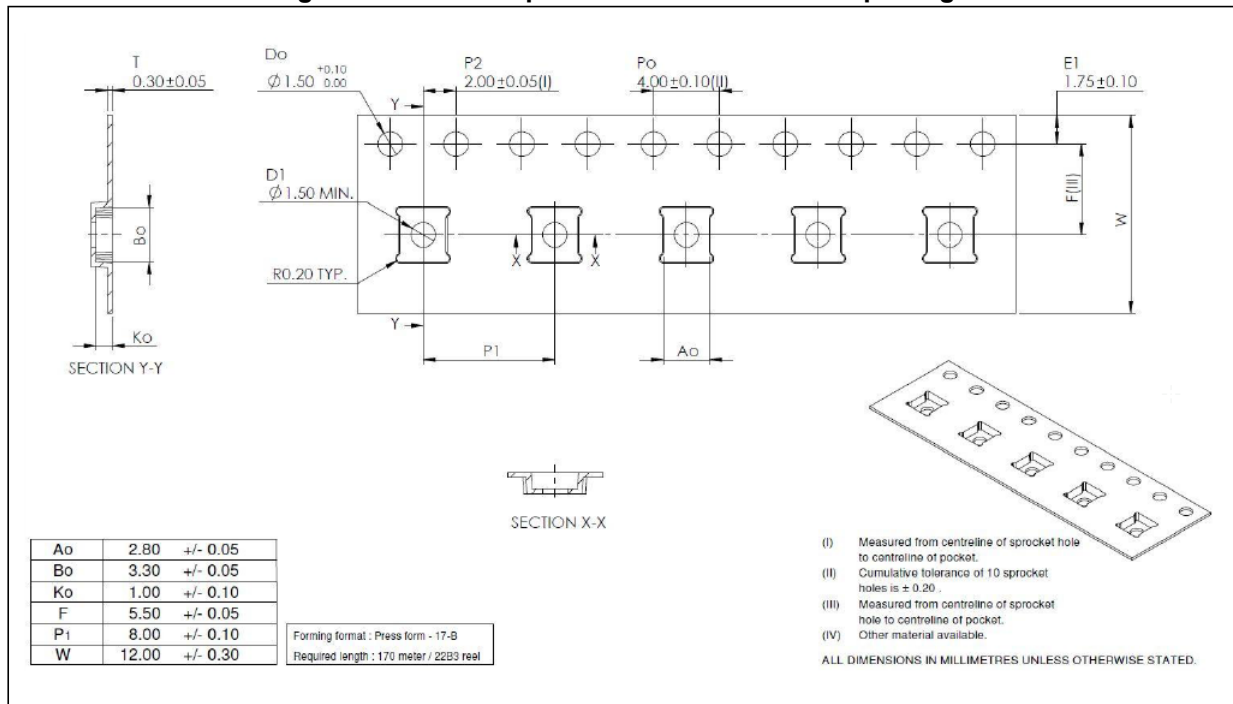

Figure 25. LGA-14 package orientation in carrier tape

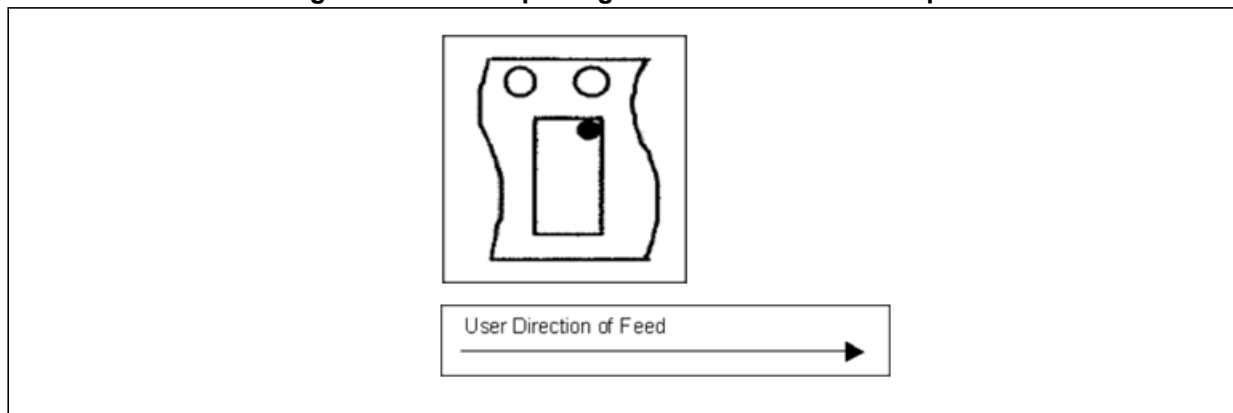

Figure 26. Reel information for carrier tape of LGA-14 package

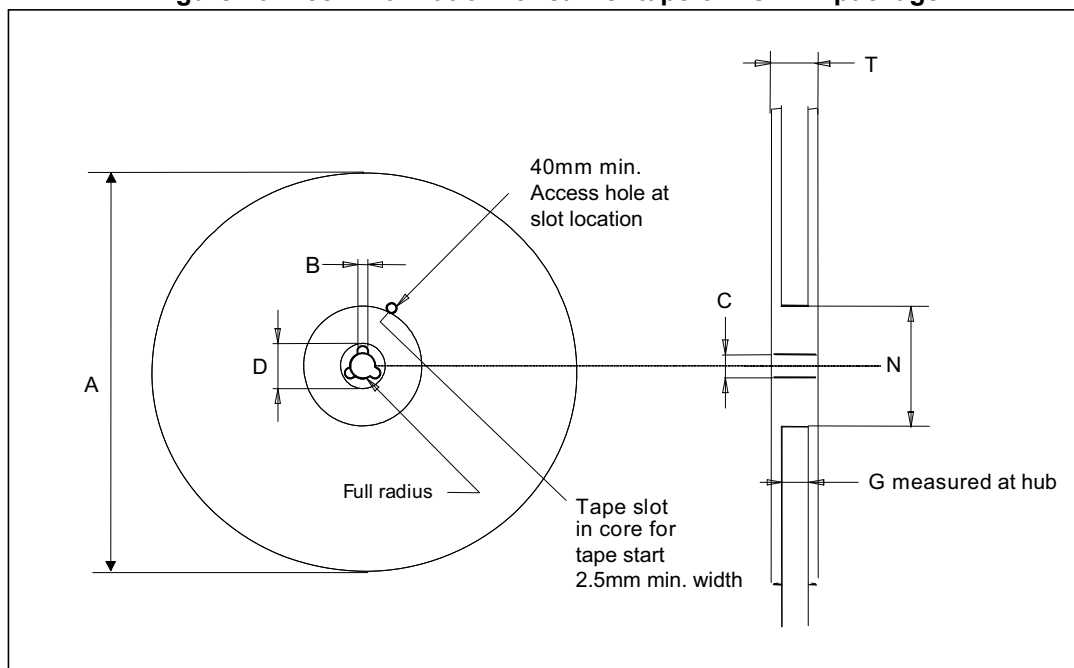

Table 310. Reel dimensions for carrier tape of LGA-14 package

Reel dimensions (mm)	
A (max)	330
B (min)	1.5
C	13 ±0.25
D (min)	20.2
N (min)	60
G	12.4 +2/-0
T (max)	18.4

16 Revision history

Table 311. Document revision history

Date	Revision	Changes
03-May-2017	6	Updated Section 4.4.2: I²C - inter-IC control interface (added Table 8: I²C master timing values) Updated Figure 13 and Figure 15 Updated footnotes 1 and 2 of Table 20: Registers address map Updated description of SW_RESET bit in Table 58: CTRL3_C register description Updated bit 0 in CTRL1_XL (10h) Updated description of INT_OIS (6Fh) , CTRL1_OIS (70h) , CTRL2_OIS (71h) and CTRL3_OIS (72h) Updated description of X_OFS_USR (73h) , Y_OFS_USR (74h) , Z_OFS_USR (75h) Minor textual updates
29-Sep-2017	7	Updated Table 3: Mechanical characteristics Specified SPI mode 3 in Section 4.4.1: SPI - serial peripheral interface and throughout Section 6: Digital interfaces

IMPORTANT NOTICE – PLEASE READ CAREFULLY

STMicroelectronics NV and its subsidiaries (“ST”) reserve the right to make changes, corrections, enhancements, modifications, and improvements to ST products and/or to this document at any time without notice. Purchasers should obtain the latest relevant information on ST products before placing orders. ST products are sold pursuant to ST’s terms and conditions of sale in place at the time of order acknowledgement.

Purchasers are solely responsible for the choice, selection, and use of ST products and ST assumes no liability for application assistance or the design of Purchasers’ products.

No license, express or implied, to any intellectual property right is granted by ST herein.

Resale of ST products with provisions different from the information set forth herein shall void any warranty granted by ST for such product.

ST and the ST logo are trademarks of ST. All other product or service names are the property of their respective owners.

Information in this document supersedes and replaces information previously supplied in any prior versions of this document.

© 2017 STMicroelectronics – All rights reserved