

Inlet with Switch

161-R301B12-E



Inlet with Switch

161-R301B12-E

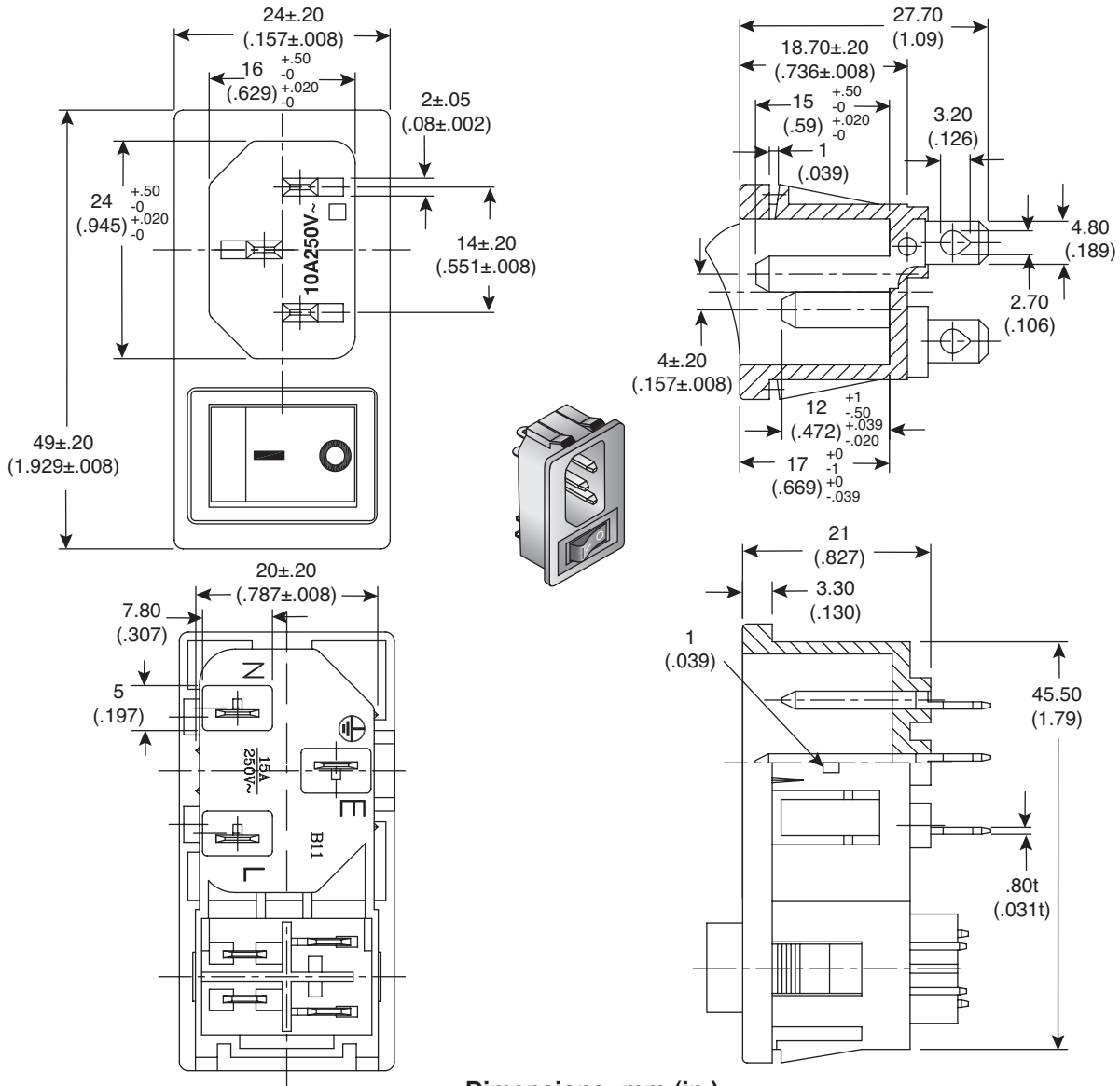

Dimensions: mm (in.)

SWITCH SPECIFICATIONS

Rating:	12(4)A 250V~ T85 (VDE)
Contact Resistance:	30MΩ Max.
Insulation Resistance:	DC 500V 100MΩ Min.
Withstand Voltage:	AC 1000V 1 Minute, 5mA
Electrical Life:	10000 Cycles at Full Load

INLET SPECIFICATIONS

Insulation Resistance:	Over 100MΩ at 500V DC
Dielectric Strength:	2000V AC 1 Minute
Body Material:	Black Glass-Fiber, Thermoplastic
RoHS Compliant	

Date Last Revised: 6/26/12

Available from Mouser Electronics
1-800-346-6873 / www.mouser.com

KC-301215

Specifications are subject to change without notice. No liability or warranty implied by this information. Environmental compliance based on producer documentation.