

PRODUCT NUMBER	DESCRIPTION	NOTES
10120707-XXXXLF	NON-HF,SEE NOTE 12&16	SEE SHT. 3
10120707-XXXXHLF	HALOGEN FREE(H),SEE NOTE 11&16	SEE SHT. 3

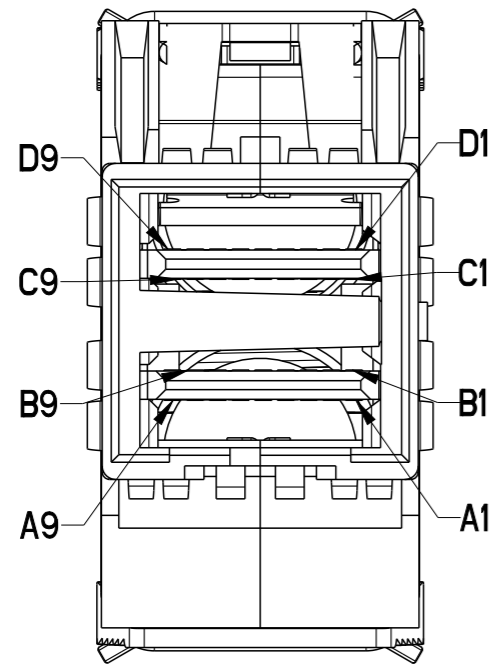

dr	David Lord	2012/04/25	projection	mm	size	A3	scale	1:2
eng	Tommy Lin	2013/11/20			ecn no		-	
chr	-	-			rel level		Released	
appr	Roger Cheng	2013/11/20	product family		C&A		-	
			title FINAL ASSEMBLY (PASSIVE) 14G MSAS HD 4X ASSEMBLY			dwg no 10120707		rev A
www.fci.com			cat. no.		-		Product - Customer Drw	
sheet 1 of 4								

PRODUCT NUMBER	DESCRIPTION	NOTES
10120707-XXXXLF	NON-HF,SEE NOTE 12&16	SEE SHT. 3
10120707-XXXXHLF	HALOGEN FREE(H),SEE NOTE 11&16	SEE SHT. 3



P1
VIEW A
SCALE 4:1



BEND RADIUS
TOP VIEW OF CONNECTOR



MINIMUM CABLE BEND TABLE					
CABLE	A	B	C	D (nominal)	("DIM Y") NON-HF
26 AWG	29.5	13.0	40.4	∅6.73	82.9
30 AWG			31.3	∅5.21	73.8

MINIMUM CABLE BEND TABLE					
CABLE	A	B	C	D (nominal)	("DIM Y") HF
26 AWG	29.5	13.0	40.4	∅6.73	82.9
30 AWG			31.3	∅5.21	73.8

WIRING LIST (SEE NOTE 6)					
END P1			END P2		
POSITION	SYMBOL		POSITION	SYMBOL	
D9	GROUND	-----	B9	GROUND	
D8	Tx2-	⊖	B8	Rx2-	
D7	Tx2+	⊕	B7	Rx2+	
D6	GROUND	-----	B6	GROUND	
D5	Tx0-	⊖	B5	Rx0-	
D4	Tx0+	⊕	B4	Rx0+	
D3	GROUND	-----	B3	GROUND	
D2	Vman	↔	B2	ModPrsL	
D1	Vact	↔	B1	Vact	
C1	SCL	↔	A1	Reserved	
C2	SDA	↔	A2	IntI	
C3	GROUND	-----	A3	GROUND	
C4	Tx1+	⊕	A4	Rx1+	
C5	Tx1-	⊖	A5	Rx1-	
C6	GROUND	-----	A6	GROUND	
C7	Tx3+	⊕	A7	Rx3+	
C8	Tx3-	⊖	A8	Rx3-	
C9	GROUND	-----	A9	GROUND	
B9	GROUND	-----	D9	GROUND	
B8	Rx2-	⊖	D8	Tx2-	
B7	Rx2+	⊕	D7	Tx2+	
B6	GROUND	-----	D6	GROUND	
B5	Rx0-	⊖	D5	Tx0-	
B4	Rx0+	⊕	D4	Tx0+	
B3	GROUND	-----	D3	GROUND	
B2	ModPrsL	↔	D2	Vman	
B1	Vact	↔	D1	Vact	
A1	Reserved	↔	C1	SCL	
A2	IntI	↔	C2	SDA	
A3	GROUND	-----	C3	GROUND	
A4	Rx1+	⊖	C4	Tx1+	
A5	Rx1-	⊕	C5	Tx1-	
A6	GROUND	-----	C6	GROUND	
A7	Rx3+	⊖	C7	Tx3+	
A8	Rx3-	⊕	C8	Tx3-	
A9	GROUND	-----	C9	GROUND	

SHIELD-----SHIELD

dr	David Lord	2012/04/25	projection	mm	size	A3	scale	1:2		
eng	Tommy Lin	2013/11/20			ecn no	-	rel level	Released		
chr	-	-								
appr	Roger Cheng	2013/11/20	product family	C&A	rel level	Released				
			FINAL ASSEMBLY (PASSIVE)			dwg no		10120707	rev	A
www.fci.com			cat. no.			Product - Customer Drw			sheet 2 of 4	

NON-HALOGEN FREE
CABLE ASSEMBLY PART NUMBERS
SEE NOTE 12&16

FCI PART NUMBER	LENGTH "DIM L" (Meters)	"DIM M" (mm)	AWG
10120707-2005LF	0.5	17.3	30
10120707-2010LF	1.0	17.3	30
10120707-2015LF	1.5	17.3	30
10120707-2020LF	2.0	17.3	30
10120707-4010LF	1.0	20.1	26
10120707-4020LF	2.0	20.1	26
10120707-4025LF	2.5	20.1	26
10120707-4030LF	3.0	20.1	26
10120707-4035LF	3.5	20.1	26
10120707-4040LF	4.0	20.1	26

HALOGEN FREE
CABLE ASSEMBLY PART NUMBERS
SEE NOTE 11&16

FCI PART NUMBER	LENGTH "DIM L" (Meters)	"DIM M" (mm)	AWG
10120707-2005HLF	0.5	17.3	30
10120707-2010HLF	1.0	17.3	30
10120707-2015HLF	1.5	17.3	30
10120707-2020HLF	2.0	17.3	30
10120707-4010HLF	1.0	20.1	26
10120707-4020HLF	2.0	20.1	26
10120707-4025HLF	2.5	20.1	26
10120707-4030HLF	3.0	20.1	26
10120707-4035HLF	3.5	20.1	26
10120707-4040HLF	4.0	20.1	26



Copyright FCI.

dr	David Lord	2012/04/25	projection 	mm 	size	A3	scale	1:2
eng	Tommy Lin	2013/11/20			ecn no	-		
chr	-	-			rel level	Released		
appr	Roger Cheng	2013/11/20	product family	C&A				
		title FINAL ASSEMBLY (PASSIVE) 14G MSAS HD 4X ASSEMBLY			dwg no 10120707	rev A		
www.fci.com		cat. no.	-	Product - Customer Drw		sheet 3 of 4		

PRODUCT NUMBER	DESCRIPTION	NOTES
10120707-XXXXLF	NON-HF,SEE NOTE 12&16	SEE SHT. 3
10120707-XXXXHLF	HALOGEN FREE(H),SEE NOTE 11&16	SEE SHT. 3

NOTES:

1 - MATERIAL:

BACK SHELLS: ZINC ALLOY/ COPPER UNDERPLATE/ NICKEL OVERPLATE
 PULL TAB: THERMOPLASTIC POLYMER
 LATCH : STAINLESS STEEL
 FERRULE: BRASS
 EMI SKIRT: STAINLESS STEEL
 LOCTITE
 PADDLE CARD: PRINTED CIRCUIT SUBSTRATE
 HEAT SHRINK TUBE: POLYOLEFIN

2 - THIS PRODUCT MEETS THE RESTRICTION OF HAZARDOUS SUBSTANCES IN ELECTRICAL AND ELECTRONIC EQUIPMENT (ROHS) DIRECTIVE (2011/65/EU)

3. THIS DIMENSION IS A FINISHED PRODUCT LENGTH.

4- UNLESS OTHERWISE SPECIFIED ASSEMBLED LENGTH TOLERANCE IS TO BE:
 "DIM L" < 1 METER = ±25mm
 "DIM L" 1 METER TO 4 METERS = ± 2% OF "DIM L"
 "DIM L" > 4 METERS = +0.00/-4% OF "DIM L"

5- LABEL DETAILS:

MANUFACTURER CODE OR NAME	COUNTRY OF ORIGIN
CUSTOMER P/N OR FCI P/N	
FCI CUSTOMER DRAWING REVISION	
FCI SERIAL NUMBER	

FONT SHALL BE CLEARLY VISIBLE AND BLACK IN COLOR.

6- ALL CABLE ASSEMBLIES 100% TESTED FOR CONTINUITY AS DEFINED IN WIRING LIST.

7. PLACE A CABLE TIE EVERY 0.5 METER ON ALL ASSEMBLIES, UNLESS OTHERWISE SPECIFIED. IN CASE OF 0.5 METER CABLE ASSEMBLY, CABLE TIE IS TO BE APPLIED AT THE MIDWAY POINT.

8 - OTHER TESTING PERFORMED AS REQUIRED BY PRODUCT SPECIFICATION: GS-12-651.

9- PACKAGING OF LEAD FREE PRODUCTS MEETS LABELING AND PACKAGING PER SPECIFICATION GS-14-920. PACKAGE CABLE ASSEMBLIES PER GS-14-1272. DUST COVERS ARE TO BE ASSEMBLED PRIOR TO PACKAGING. FCI PACKAGE TRACKING BAG LABEL IS ONLY FOR REFERENCE.

10. A "△" SYMBOL WILL BE NEXT TO ANY DIMENSION, VIEW, OR NOTE WHICH HAS BEEN MODIFIED WITH THE CURRENT DRAWING REVISION. THE CURRENT REVISION WILL BE SHOWN IN THE SYMBOL.

11. "H" PRODUCT NUMBERS DESIGNATE THE USE OF HALOGEN FREE RAW CABLE.

12. HALOGEN FREE RAW CABLE CAN BE USED AS A SUBSTITUTE ON NON-HF PRODUCT NUMBERS.

13. MEETS ELECTRICAL PERFORMANCE REQUIREMENTS OF SAS 3.0

14. MATES TO SERIES: 10112626 or 10112627 or 10112628

15. EEPROM MAP INFORMATION FOLLOW FCI STANDARDS.

16. RAW CABLE IS OPTIONAL, WHICH HAD BEEN QUALIFIED BY FCI AND MEET FCI PRODUCT SPEC. GS-12-651.

LABEL EXAMPLE

FCI CHINA 10120707-2005LF REV. A CN1347HZ052L0001
--

FCI SERIAL NUMBER IS USED ONLY FOR TRACKING PRODUCT AND THE FORMAT DETAIL IS AS BELOW:

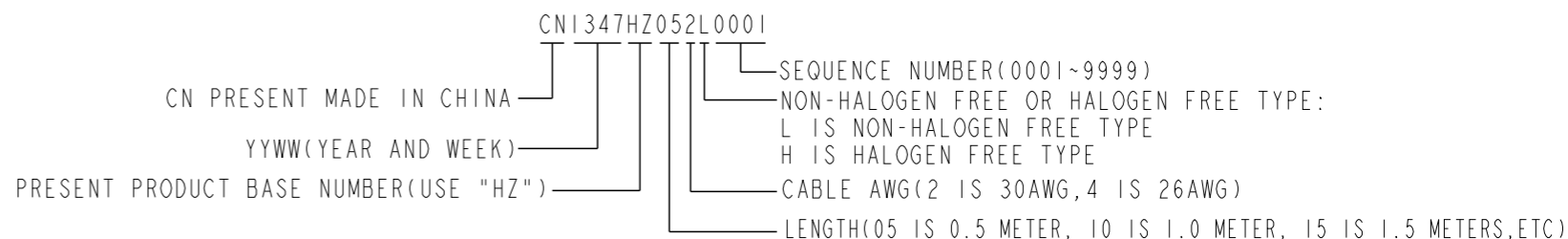

dr	David Lord	2012/04/25	projection	mm	size	A3	scale	1:2
eng	Tommy Lin	2013/11/20			ecn no	-		
chr	-	-	product family	C&A	rel level	Released		
appr	Roger Cheng	2013/11/20			www.fci.com	cat. no.	-	Product - Customer Drw
FCI		FINAL ASSEMBLY (PASSIVE)			dwg no	10120707		rev
		14G MSAS HD 4X ASSEMBLY					A	