

NOTES:

1. MATERIALS AND FINISHES:  
 BODY, COUPLING NUT & CONTACT - BRASS, SILVER PLATING  
 INSERT & SPACER - PTFE, NATURAL
2. ELECTRICAL:  
 A. DIELECTRIC WITHSTANDING VOLTAGE: 1000 VRMS, MIN.
3. MECHANICAL:  
 A. DURABILITY: 500 CYCLES MIN.  
 B. TEMPERATURE RANGE: -65° C TO +165° C
4. PACKAGING:  
 A. QUANTITY: SINGLE PACK  
 B. MARKING: BAG TO BE MARKED  
 "AMPHENOL RF, 83-886-2050, AND DATE CODE"

5. SHOWS CABLE ENTRY DIMENSIONS.

THIRD ANGLE PROJ.

REVISIONS				
REV	DESCRIPTION	DATE	ECO	APPR
--	RELEASE TO MFG.	--	--	--
E	REDRAWN IN PRO-E & COD SHEET ADDED	6/1/15	50343	KR

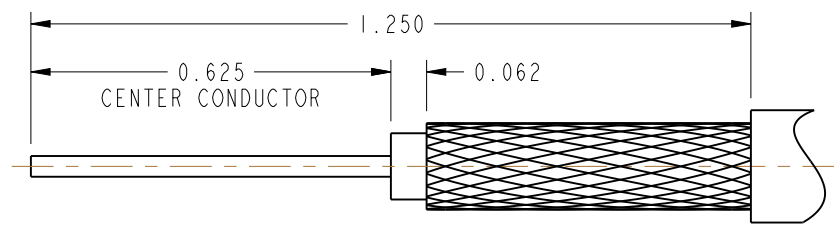

**RECOMMENDED CABLE STRIPPING DIMENSIONS**

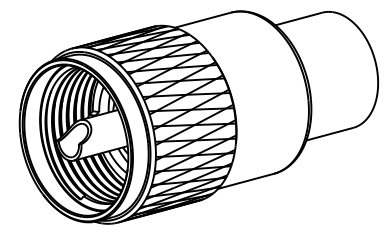

SCALE 1.250

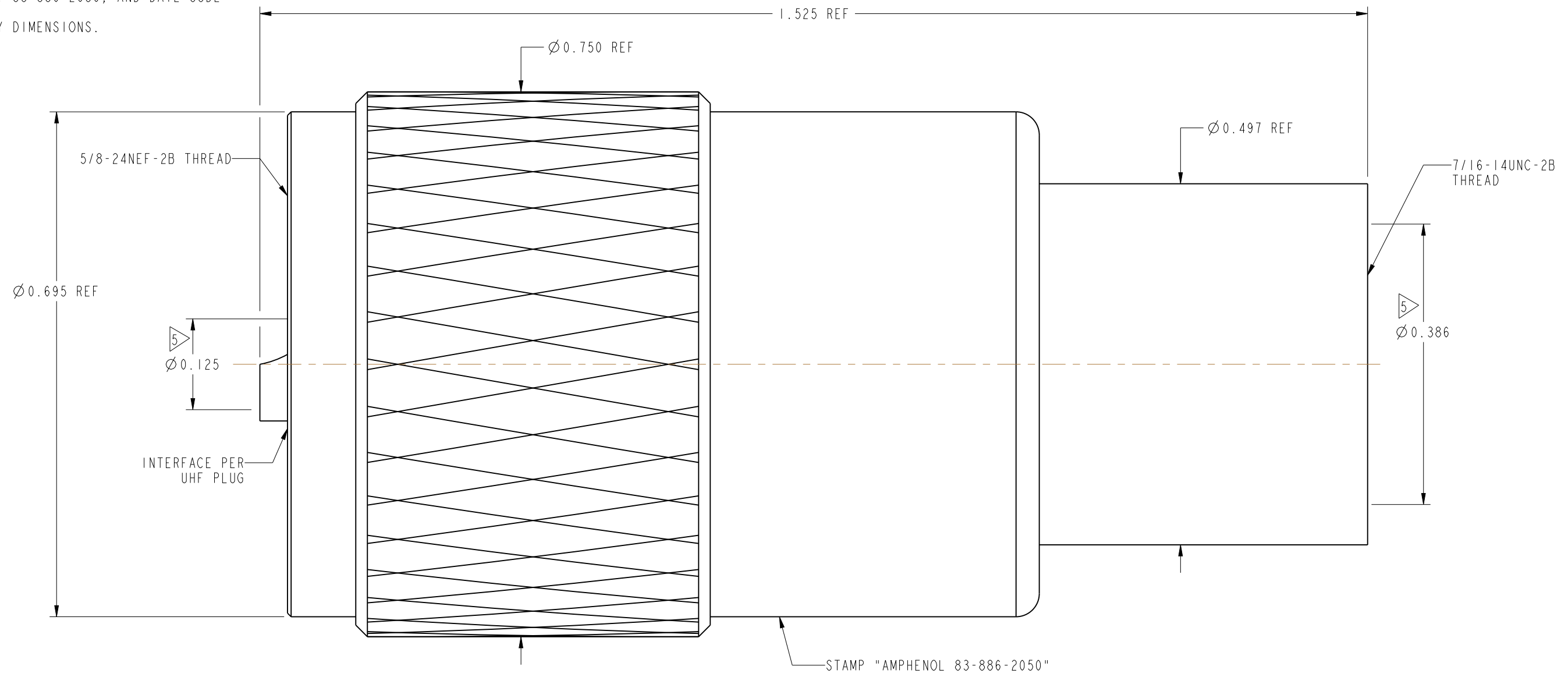

**CUSTOMER OUTLINE DRAWING**

ALL OTHER SHEETS ARE FOR INTERNAL USE ONLY

UNLESS OTHERWISE SPECIFIED, DIMENSIONS ARE IN INCHES AND TOLERANCES ARE: 2 PLACE DECIMAL 3 PLACE DECIMAL ANGLES $\pm 0.015$ (0,381 mm) $\pm 0.005$ (0,127 mm) $\pm 1^\circ$	MATERIAL	DRAWN	DATE	TITLE		Amphenol RF
	SEE NOTES	KARTHIK R	20-Mar-14			
	REFERENCE	ENGINEER	DATE	SCALE: 6.5:1.0 SHEET 2 OF 2		DRAWING NO. 83-886-2050
	DOR 21-031-315566 MOTOROLA 28C80325A29	RPA	06-Jan-77			ITEM NO. 83-886-2050
NOTICE - These drawings, specifications, or other data (1) are, and remain the property of Amphenol corp. (2) must be returned upon request; and (3) are confidential and not to be disclosed to any person other than those to whom they are given by Amphenol Corp. the furnishing of these drawings, specifications, or other data by Amphenol Corp., or to any other person to anyone for any purpose is not to be regarded by implication or otherwise in any manner licensing, granting rights to permitting such holder or any other person to manufacture, use or sell any product, process or design, patented or otherwise, that may in any way be related to or disclosed by said drawings, specifications, or other data.	CONFIGURATION LEVEL: In Work	APPROVED	DATE	DWG SIZE	REV	PART NO. 83-886-2050
FINISH		K. CAPOZZI	6/1/15	B	E	