

SIGN	DATE	DESCRIPTION	APPROVER
△	8/07'06	Added VDE and TUV standard	梁仁松
△	1/27'07	Soldering temperature changed from 245° to 250°	Tony
△	2009.10.27	The material is changed from Brass to Copper	Jacke
△	2009.10.27	The operating temperature is changed	Jacke
△	2010.10.11	The design is changed	Jacke

THIS IS CAD DRAWING, DO NOT REVISE MANUALLY!!!

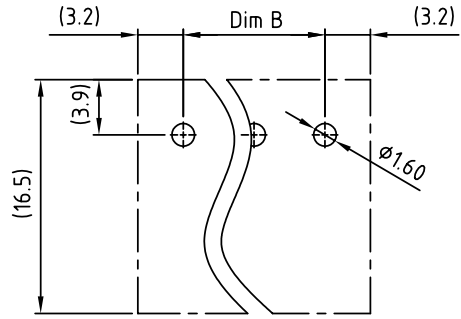
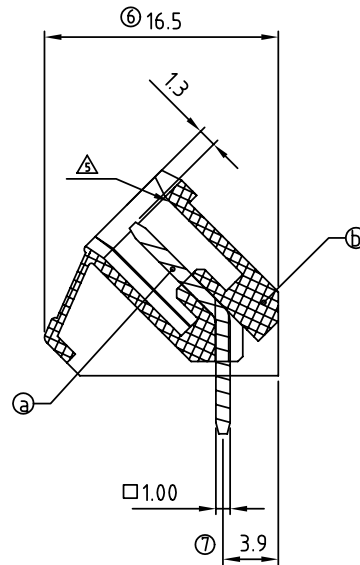
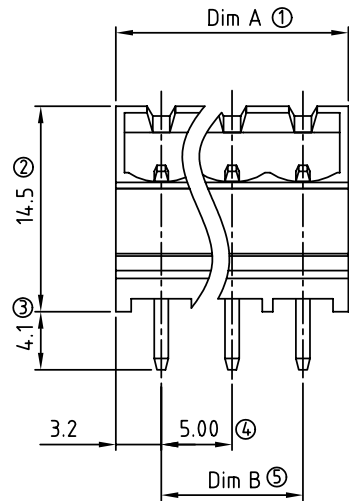
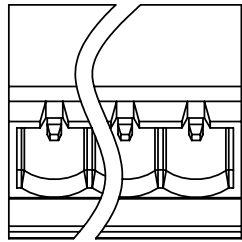

RECOMMENDED PCB LAYOUT

N = Number of poles
 Dim A = (N-1) x 5.0 + 6.4
 Dim B = (N-1) x 5.0

	Dim A	Dim B
2-6p	±0.15	±0.15
7-12p	±0.20	±0.20
13-18p	±0.30	±0.30
19-24p	±0.40	±0.40

Material:

- Item A Male contact pin: Copper Tin plated
- Item B Terminal (housing): Thermoplastic (UL94V-0)

- △ Electrical: cULus /VDE/TUV
- Voltage rating: 300V/300V/300V
- Current rating: 15A/17A/20A
- Withstanding Voltage: 1.6 KV/2.5KV/2.5KV
- Operating temperature: -40°C to +115°C
- Soldering temperature: 250°C±10°C/5 Sec
- Safety Approval:

VK xx 7 1 x 0 xxxx G

No. OF POLES
 02: 2 POLES
 :
 24: 24 POLES

COLOR
 0 Black (RAL9005)
 2 Red (RAL3001/D)
 3 Orange(RAL2011/P)
 4 Yellow(RAL1018/A)
 5 Green(RAL6018/T)
 6 Blue (RAL5015/A)
 8 Grey(RAL7035/D)

G: Pb<4000ppm
 0000: "@" Logo (Standard)
 000A: "ANYTEK" Mark
 Any special item by customer request. please contact sales department.

ANYTEK				CUSTOMER COPY			
ALL RIGHTS RESERVED. REPRODUCTION OR ISSUE TO THIRD PARTIES IN ANY FORM WHATSOEVER IS NOT PERMITTED WITHOUT WRITTEN AUTHORITY FROM THE PROPRIETOR. PROPERTY OF ANYTEK TECHNOLOGY CO., LTD							
TITLE		VK-5.0 Series Close type					
PART NO.		VKxx71x0xxxxG			DWG NO.		8VK0201
APPROVED		CHECKED	DESIGNED	DRAWN	CUST NO.		Tolerance
			Jacke 2010.10.11	Jacke 2009.10.27			X. ±0.50 X.X ±0.30 X.XX ±0.10 X° ±1°
						UNIT: mm	
				SHEET: 01/01		SCALE: NONE	
						REV.: G	