

Edco PC642 Series

Zone/Loop/Data

The Edco PC642 Series surge protective device, (SPD) is a two-pair (four wire) module implementing three-stage hybrid technology. This SPD addresses over-voltage transients with gas tubes and silicon avalanche components. In addition, sneak and fault currents are mitigated with resettable fuses (PTCs). The PTCs increase resistance several orders of magnitude when over-currents exceed safe levels. A normal state resumes when over-currents are removed. The ability to self-restore in this manner significantly increases suppressor performance and survivability.

The Edco PC642 card edge is gold-plated, double sided and is designed to mate with the Edco PCB1B-WKEY gold-plated female terminal connector (sold separately). When snapped together, the data circuits “pass thru” the protector in a serial fashion from the four “Field Side” terminals to the four “Electronics Side” terminals. Terminals 1 or 10 of the PCB1B must be attached to Building-Approved Ground.

General Technical Specifications

Maximum Operating Voltage	5, 30, 36, 250 VDC
Clamping Voltage	8, 36, 43, 300 VDC
Operating Current	0.15 A
Peak Surge Current	10 kA (8 x 20 μ s)
Frequency Range	0 to 20 MHz
Insertion Loss	< 0.1 dB at 50 MHz
SPD Technology	GDT, SAD, w/ Series PTC
Connection Type	Terminal Block, w/ compression lugs Terminals accept up to 10 AWG
Operating Temperature	-40°C to +85°C
Dimensions (in / mm)	2.0" H x 1.0" W x 2.5" L (PC642 + Base) [50.8 x 25.4 x 63.5 mm]
Weight (oz / kg)	1 oz [0.03 kg]
Certifications	UL 497A

Caution

Do not place this product in service on any signal line capable of supplying more than 150 mA continuously.

Attention

Ne pas placer ce produit dans le service sur une ligne de signal capable de fournir en permanence plus de 150 mA.

DANGER!

Only qualified personnel should install or service this system. Electrical safety precautions must be followed when installing or servicing this equipment. To prevent risk of electrical shock, turn off and lock out all power sources to the unit before making electrical connections or servicing.

Seulement le personnel qualifié doit installer ou maintenir ce système. Des précautions de sécurité en électricité doivent être suivies lors de l'installation ou de la maintenance de cet équipement. Pour éviter tout risque de choc électrique, débranchez et verrouillez toutes les sources d'alimentation de cet équipement avant de.



EDCO PCB1B-WKEY BASE SOLD SEPARATELY

Features

- Three-stage hybrid protection
- Sneak/fault current protection
- Resettable fuses – PTCs
- Low capacitance option
- Plug-in module
- Requires Edco PCB1B-WKEY base
- Fast response time
- UL listed 497B
- 5 year warranty



Installation Instructions

Terminal Assignments

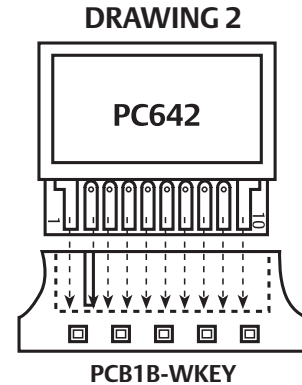
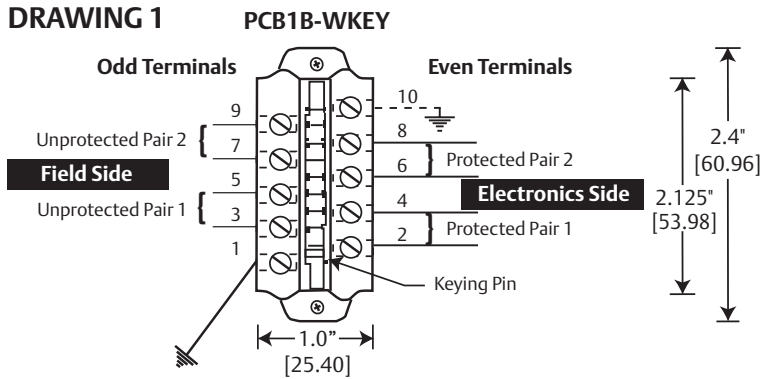

Ground Terminal 1 or 10 to Building Approved Ground (preferably AC Power safety ground).

DO NOT daisy chain grounds. NOT intended for shield termination. Install ground in accordance with all applicable codes.

Read and Understand These Instructions

Note:

- These protectors are intended for indoor use on communication loop circuits which have been isolated from the Public Switch Telephone Network.
- The communication loop circuits shall not be exposed to accidental contact with the electric light or power conductors.
- The protectors shall be installed per the applicable requirements of the National Electric Code, ANSI/NFPA 70.
- Measure DC operating voltage of system to insure it does not exceed the rating of the selected surge device (5-250 VDC depending on the device).

Installation:

1. Turn off power to circuit to be protected prior to installation.
2. Screw mounting base #PCB1B-WKEY (ordered separately) in desired location preferably as close to protected equipment as possible and in close proximity to a building approved grounding point using (2) #4 screws. PCB1B may also be DIN rail mounted using optional DIN clip assembly #11604KIT-PC (ordered separately).
3. Attach field side pairs (26-10 AWG) to positions 3/5 and 7/9, attach electronics side pairs (26-10 AWG) to positions 2/4 and 6/8. Attach ground wire (10 AWG) to positions 1 or 10 on base. **See Drawing 1.** Torque wires to 44 lbf/in [8 kgf/cm].
4. Insert PC642C module into keyed PCB1B-WKEY base. **See Drawing 2.**
5. Apply power to protected circuit.

Emerson Network Power Contact information

Surge Protection
100 Emerson Parkway
Binghamton, NY 13905
T: (607) 721-8840
T: (800) 288-6169
F: (607) 722-8713
E: SurgeTech@Emerson.com

Ordering Information

APPLICATIONS	PART NUMBER
RS485, RS422	PC642C-008LC & PCB1B-WKEY
RS232	PC642C-036LC & PCB1B-WKEY
E-NET, 10 BASE T	PC642C-036LC & PCB1B-WKEY
4-20 ma	PC642C-036LC & PCB1B-WKEY
OPTION	PART NUMBER
DIN Rail Kit Available	11604KIT-PC

How to Specify the Appropriate Model

*Other configurations available, please contact factory.

MODEL	MAX. OPERATING VOLTAGE	CLAMPING VOLTAGE (1000V@1 mA)
PC642C-008LC	5 VDC	8 VDC
PC642C-036LC	30 VDC	36 VDC
PC642C-043LC	36 VDC	43 VDC
PC642C-200LC	43-250 VDC	300 VDC

www.EmersonNetworkPower.com/Surge

