

MATERIAL NO.	ENGINEERING NO.	LENGTH	POLES
1206142001	LW04000K03M020	78.7 (2M)	4
1206142002	LW05000K03M020	78.7 (2M)	5

NOTICE: THIS PART IS CSA AND FACTORY MUTUAL APPROVED
NO CHANGES CAN BE MADE TO THE ASSEMBLY, COMPONENTS
OR SUPPLIER WITHOUT PRIOR APPROVAL FROM CSA AND
FACTORY MUTUAL.

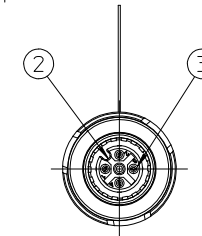
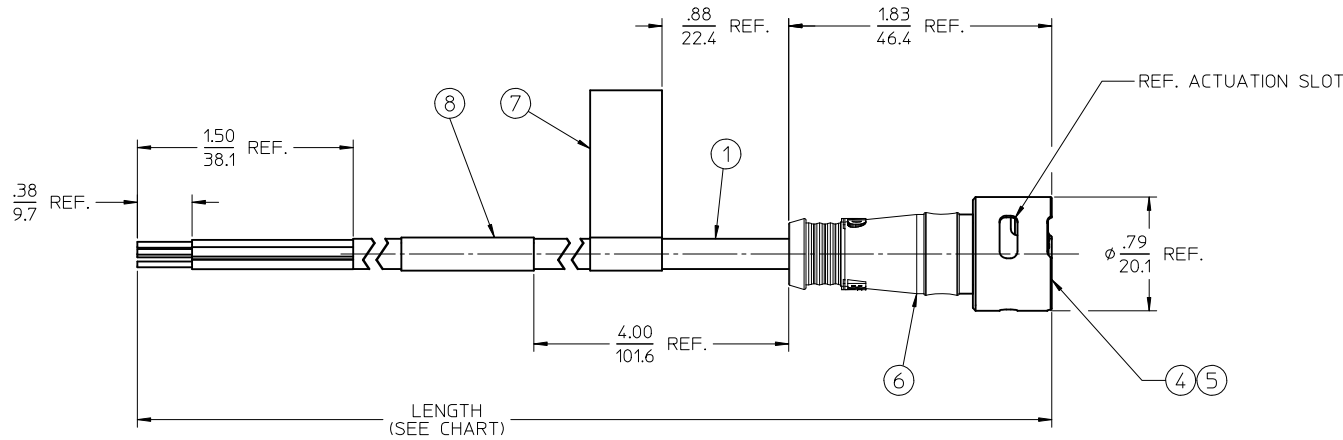
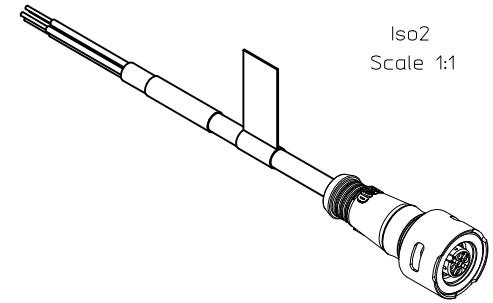

NOTES:

1. MATERIAL: SEE TABLE
2. FINISHES: SEE TABLE
3. PRODUCT SPECIFICATIONS: PS-120614-001
4. CONTROL DOC: ES-120614-001
5. 3 & 4 POLE ELECTRICAL SPECIFICATIONS:
VOLTAGE RATING: 125V
CURRENT RATING: 4 AMPS
6. 5 POLE ELECTRICAL SPECIFICATIONS:
VOLTAGE RATING: 32V
CURRENT RATING: 4 AMPS

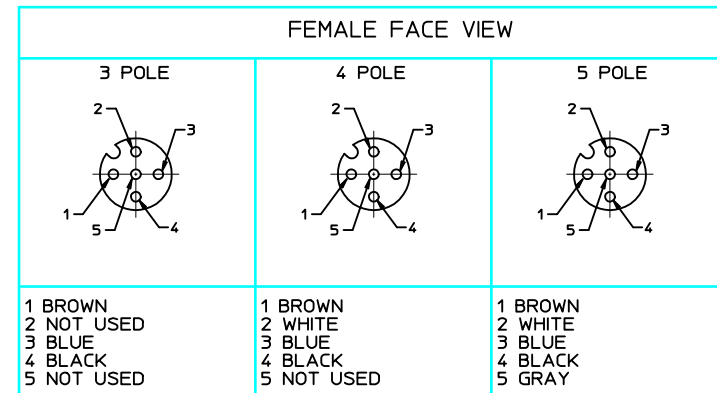

8	1	WRAP LABEL	PLASTIC FILM	BLACK/YELLOW
7	1	FLAG LABEL (WARNING)	POLYESTER	BLACK/ORANGE
6	1	OVERMOLD	TPE	YELLOW
5	1	OUTER SLEEVE	ST. STEEL	PASSIVATED
4	1	INNER SLEEVE	ST. STEEL	PASSIVATED
3	XX	CONTACT	Cu ALLOY	GOLD PLATED
2	1	INSERT	PUR	BLACK
1	1	CABLE, #18 AWG ITC/PLTC	TPE	YELLOW
ITEM	QTY.	DESCRIPTION	MATERIAL	FINISH

RELEASED	EC NO: MNA2012-0225	2011/11/21	DRWINRSTONE
	CHKDL: HARTMANN	2012/01/27	
	APPR: JFMURPHY	2012/04/18	
REV	DESCRIPTION	DATE	BY
A			

QUALITY SYMBOLS
 = 0
 = 0.01

GENERAL TOLERANCES (UNLESS SPECIFIED)

	mm	INCH
4 PLACES	± .01	± .0004
3 PLACES	± .02	± .0008
2 PLACES	± .03	± .0012
1 PLACE	± 0.3	± .0118
ANGULAR ± 2°		

DRAFT WHERE APPLICABLE
MUST REMAIN
WITHIN DIMENSIONS

DIMENSION STYLE
IN/MM

DRAWN BY	DATE
RSTONE	2011/11/21
CHECKED BY	DATE
L. HARTMANN	2012/01/27
APPROVED BY	DATE
JFMURPHY	2012/04/18

SEE CHART

THIS DRAWING CONTAINS INFORMATION THAT IS PROPRIETARY TO MOLEX INCORPORATED AND SHOULD NOT BE USED WITHOUT WRITTEN PERMISSION

SCALE
1.5:1

DESIGN UNITS
INCH

DOCUMENT NO.

THIRD ANGLE PROJECTION

ULTRA-LOCK ZONE 2
FEMALE, STRAIGHT
K03, 18 AWG, TPE

MOLEX INCORPORATED

SD-120614-011
SHEET NO. 1 OF 1