

# EC-SYSTEMS

Options	330
Switch power supplies	334
External commutation electronics for rail technology	338
Accessories: Temperature sensor / control module, pressure control, selection module, interface converter, ...	340
HMS controller	358

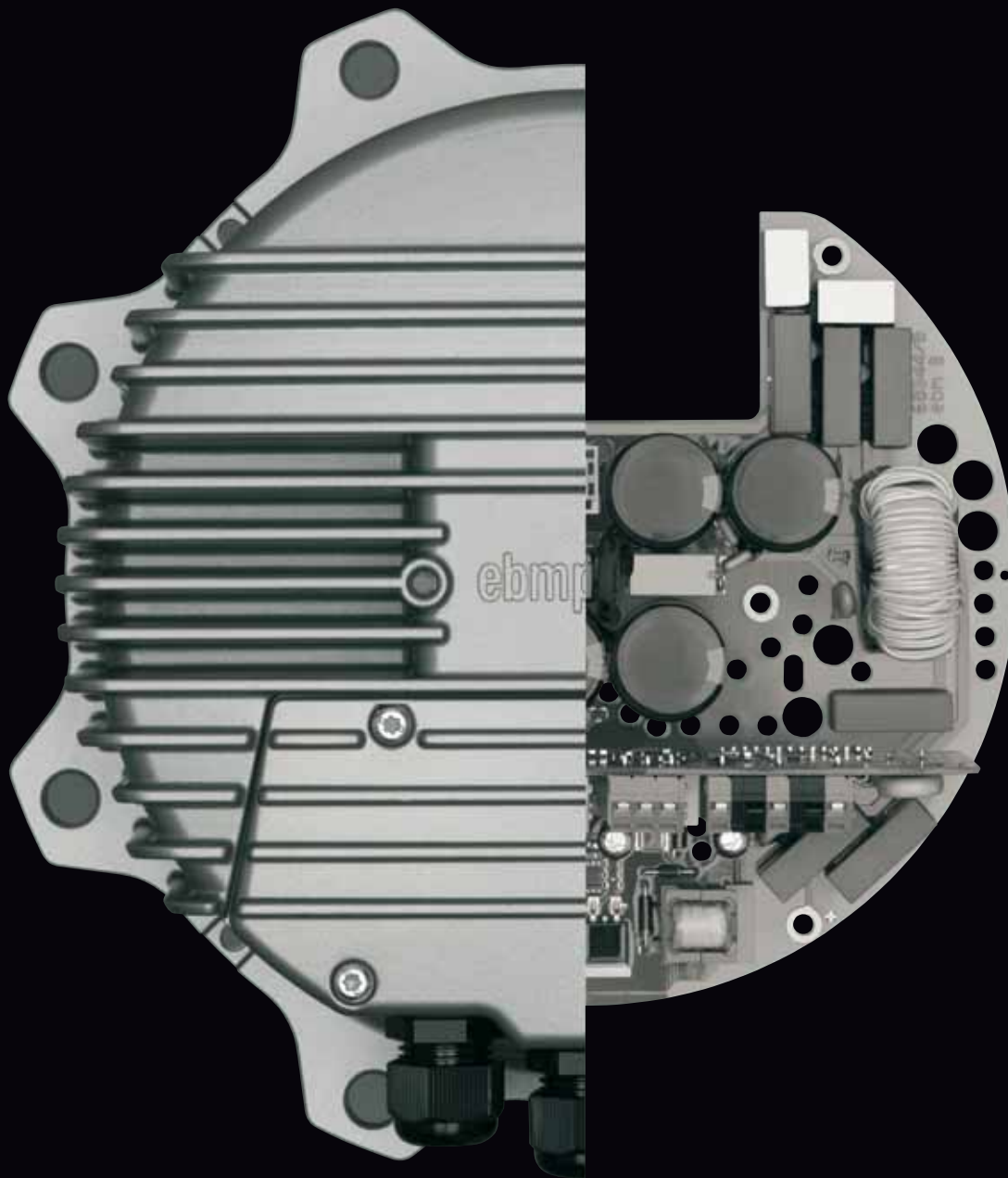

# EC-SYSTEMS

## Options

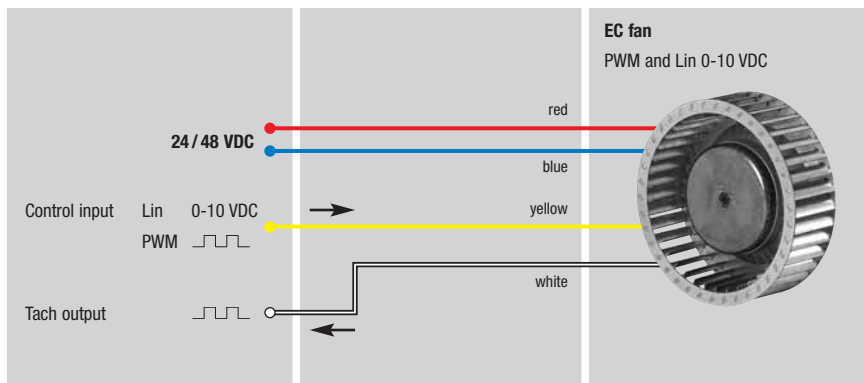

### EC fans 24 / 48 VDC with integrated commutation electronics

#### Linear input:

< 1 VDC -> n=0  
1 VDC -> n<sub>min</sub>  
10 VDC -> n<sub>max</sub>

#### PWM input:

< 10% PWM -> n=0  
10% PWM -> n<sub>min</sub>  
100% PWM -> n<sub>max</sub>

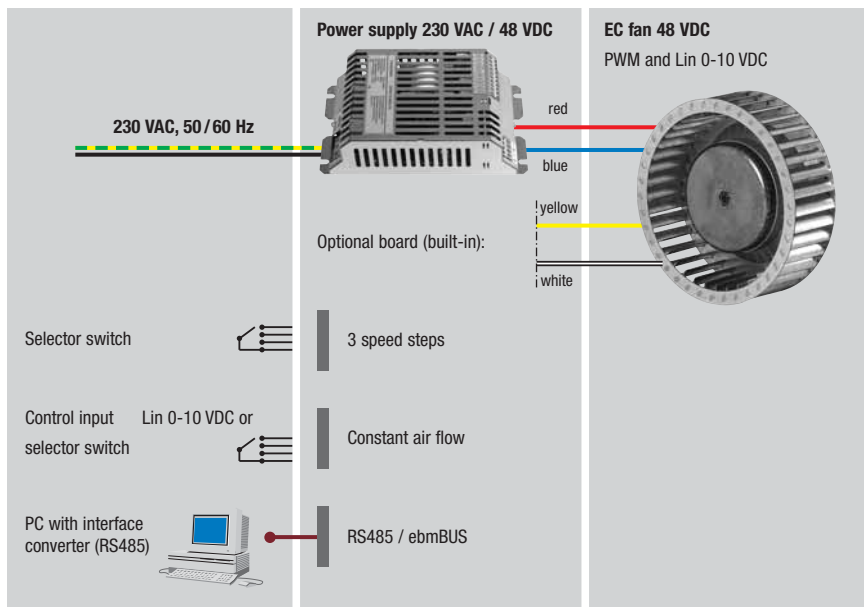

### EC fans 48 VDC with integrated commutation electronics

#### Linear input:

< 1 VDC -> n=0  
1 VDC -> n<sub>min</sub>  
10 VDC -> n<sub>max</sub>

#### PWM input:

< 10% PWM -> n=0  
10% PWM -> n<sub>min</sub>  
100% PWM -> n<sub>max</sub>

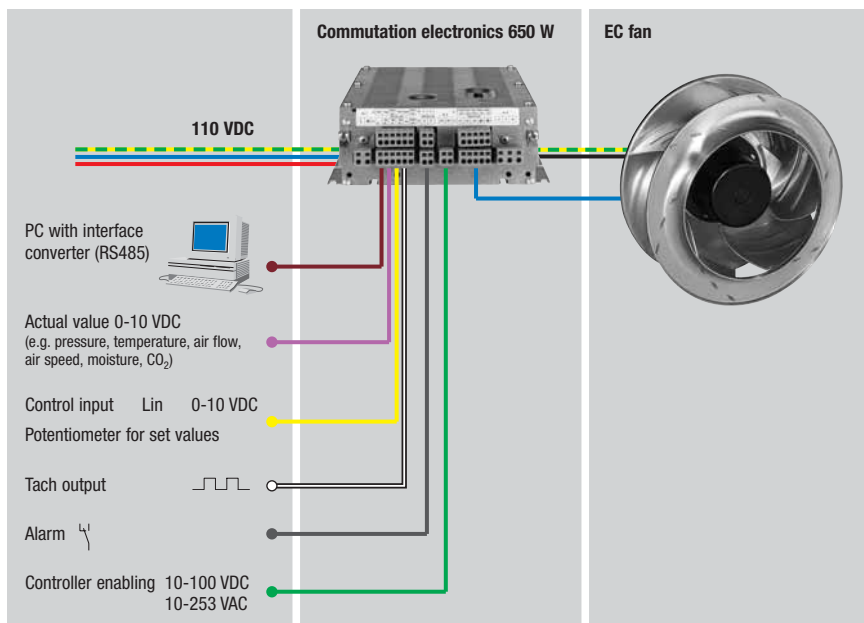

### EC fans with external commutation electronics 650 W, 110 VDC (rail technology)

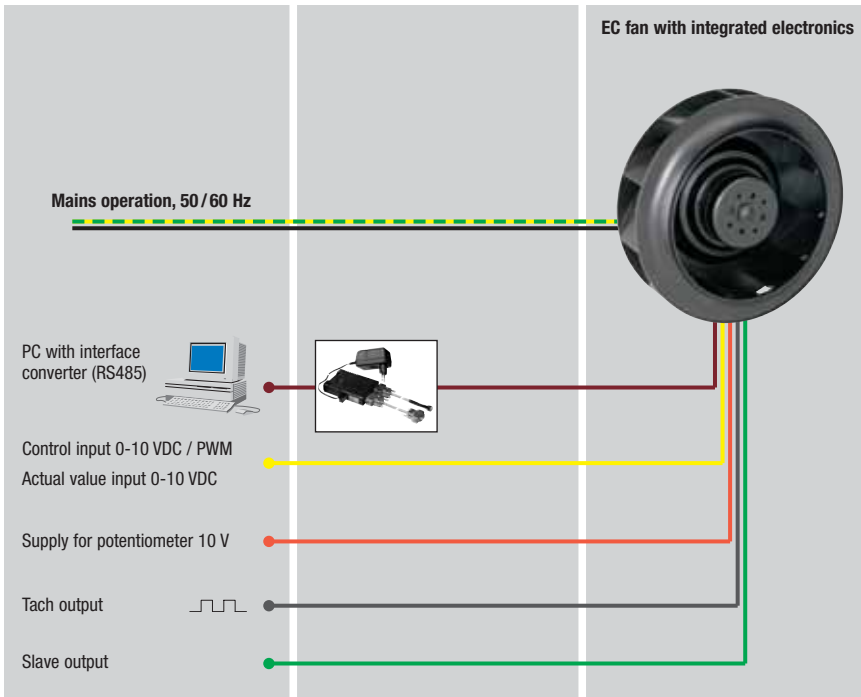

**EC fans (motor size 055)  
with integrated commutation electronics**  
1~ 115 VAC or 230 VAC  
50/60 Hz mains operation

**EC fans (motor size 074)  
with integrated commutation electronics**  
1~ 100 -130 VAC or 200 -277 VAC  
50/60 Hz mains operation

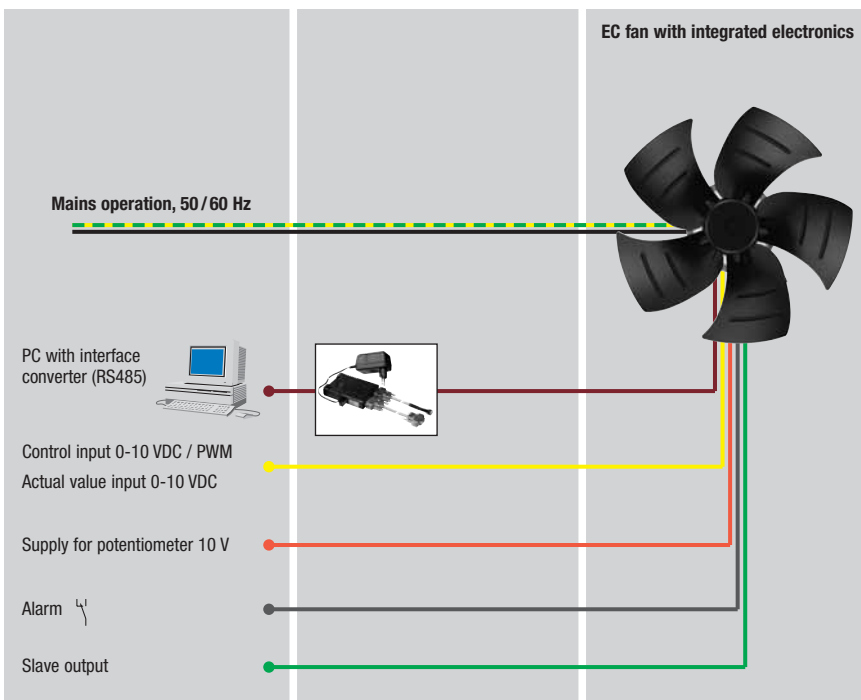

**EC fans (motor size 084)  
with integrated commutation electronics**  
1~ 100 -130 VAC or 200 -277 VAC  
50/60 Hz mains operation

# EC-SYSTEMS

## Options

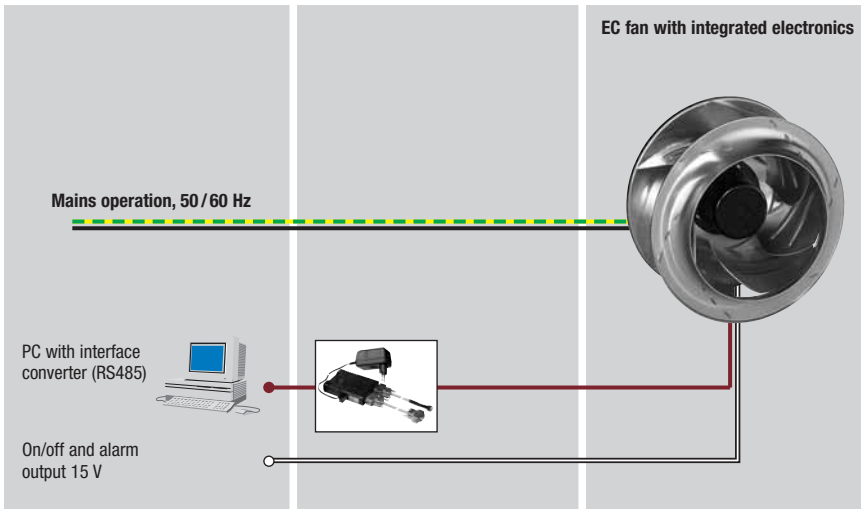

**EC fans (motor size 084, ebmBUS) with integrated commutation electronics**  
 1~ 200-277 VAC,  
 50/60 Hz mains operation

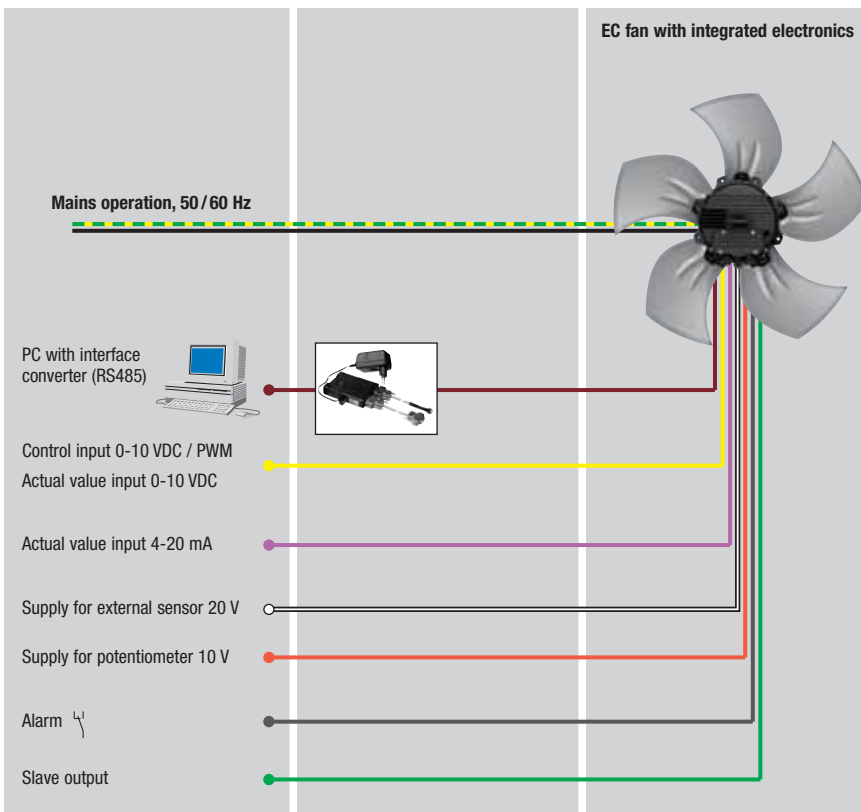

**EC fans (motor size 112/150) with integrated commutation electronics**  
 1~ 200-277 VAC or  
 3~ 200-240 / 380-480 VAC  
 50/60 Hz mains operation

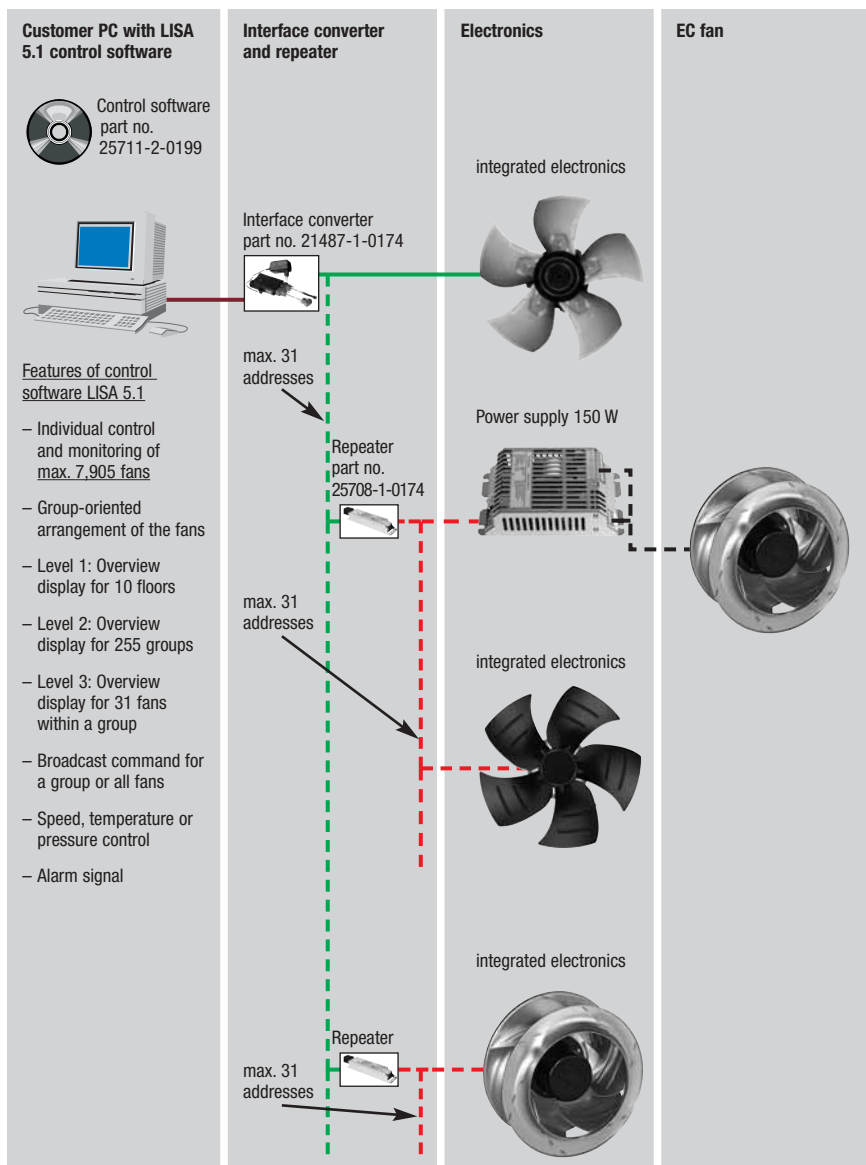

**EC-SYSTEMS:  
Networked EC fans with interface  
converter and repeater**

# Switch power supply with PFC, basic version

48 VDC, 150 W / 300 W



- **General remarks:** Switch power supply with an output power of 150 W / 300 W to supply 48 VDC EC motors from the 115 / 230 VAC mains. It is also possible to run several motors up to an overall power of 150 W / 300 W. Data on the 60 W switching power supply is available on request.
- **Function:** Supply of an electrically insulated direct voltage of 48 VDC at the output when connected to the 115 / 230 V mains. The power supply is sustainably short-circuit proof, open-circuit proof and protected against overheating. An integrated EMC filter guarantees RFI suppression of the unit according to EN 61000-3-2.
- **Material:** Housing made of stainless steel
- **Protection class:** I
- **Type of protection:** IP 20 (acc. to EN 60529)

Nominal data	Nominal voltage	Frequency	Output voltage	Output $P_1$ max.	Rated output current	Mass	Dimensions					
							Type	VAC	Hz	VDC	W	A
CNW015-AB06 -01	1~ 115	50/60	48	150	3.10	0.7	187	176	167	50	110	1
CNW015-AB02 -01	1~ 230	50/60	48	150	3.10	0.7	187	176	167	50	110	1
CNW030-AC06 -01	1~ 100-120	50/60	48	300	6.25	1.3	272	260	251	66	112	2
CNW030-AC02 -01	1~ 200-277	50/60	48	300	6.25	1.3	272	260	251	66	112	2

subject to alterations

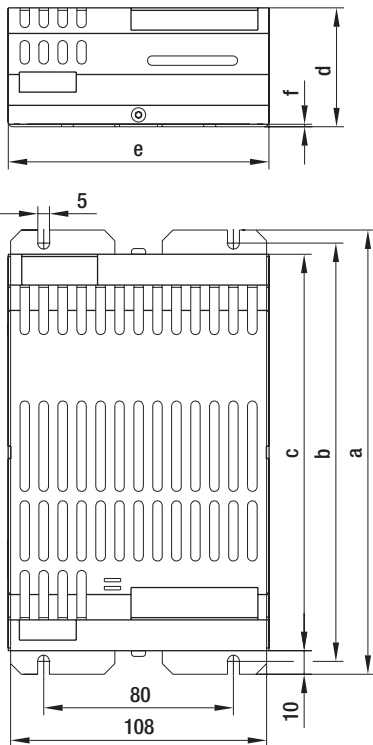

- **EMC:** Interference emission acc. to EN 61000-6-3  
Interference immunity acc. to EN 61000-6-1
- **Product conforming to standards:** EN 50178, CE
- **Approvals:** UL/CSA (File No. E 181381)

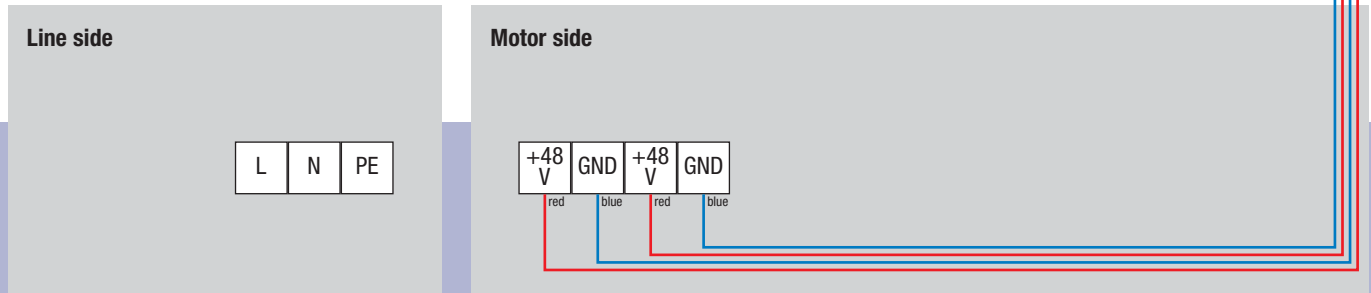

# Switch power supply with PFC, RS485 and ebmBUS

48 VDC, 150 W / 300 W



- **General remarks:** Switch power supply with an output power of 150 W / 300 W to supply 48 VDC EC motors from the 115 / 230 VAC mains. It is also possible to run several motors up to an overall power of 150 W / 300 W. Data on the 60 W switching power supply is available on request.
- **Function:** Supply of an electrically insulated direct voltage of 48 VDC at the output when connected to the 115 / 230 V mains. The power supply is sustainably short-circuit proof, open-circuit proof and protected against overheating. An integrated EMC filter guarantees RFI suppression of the unit according to EN 61000-3-2.
- **Material:** Housing made of stainless steel
- **Protection class:** I
- **Type of protection:** IP 20 (acc. to EN 60529)

Nominal data	Nominal voltage	Frequency	Output voltage	Output P <sub>1</sub> max.	Rated output current	Mass	Dimensions					
							Type	VAC	Hz	VDC	W	A
CNW015-AB06 -05	1~ 115	50/60	48	150	3.10	0.7	187	176	167	50	110	1
CNW015-AB02 -05	1~ 230	50/60	48	150	3.10	0.7	187	176	167	50	110	1
CNW030-AC06 -05	1~ 100-120	50/60	48	300	6.25	1.3	272	260	251	66	112	2
CNW030-AC02 -05	1~ 200-277	50/60	48	300	6.25	1.3	272	260	251	66	112	2

subject to alterations

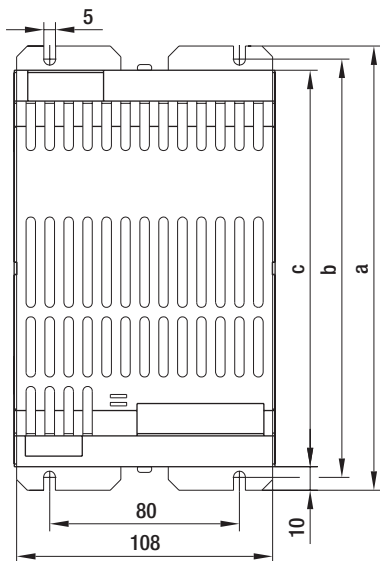
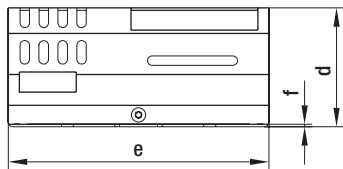

- **EMC:** Interference emission acc. to EN 61000-6-3  
Interference immunity acc. to EN 61000-6-1
- **Product conforming to standards:** EN 50178, CE
- **Approvals:** UL/CSA (File No. E 181381)
- **Technical features:** Control board for RS485, ebmBUS and LISA functions



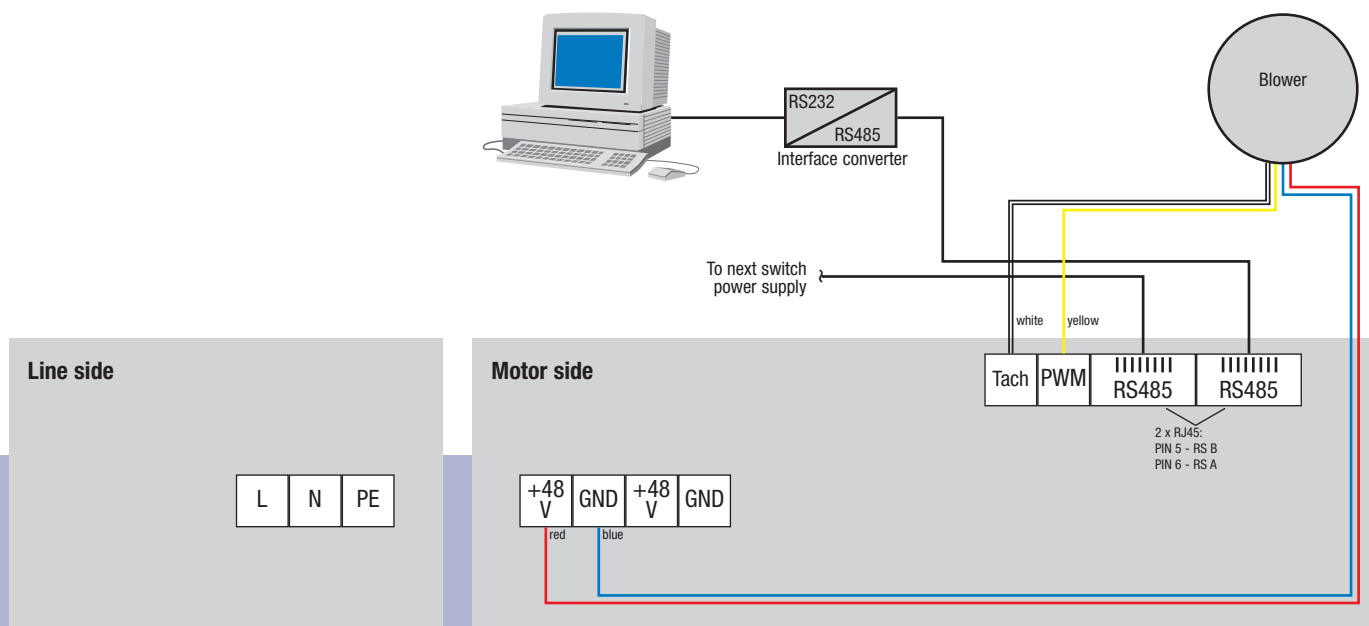

# External commutation electronics

for rail technology, 110 VDC, 650 W



- **General remarks:** For EC motors and fans with 3 cores and without integrated commutation electronics
- **Function:** Commutation unit for three-core EC motors up to a power input of 650 W. Various basic functions are integrated: open loop speed control, closed loop speed control, RS485 interface. In combination with sensors, all control tasks as required in air technology can be executed.
- **Protection class:** I
- **Type of protection:** IP 20 (acc. to DIN EN 60529)
- **NB:** Connected fans have to be designed for a rated voltage of 127 VDC!

Nominal data	Nominal voltage	Power input $P_1$ max.	Current draw	Perm. amb. temp.	Mass
Type	VDC	W	A	°C	kg
CEG 485-HB50 -01	110	650	5.9	-25 to +40	2.0

subject to alterations

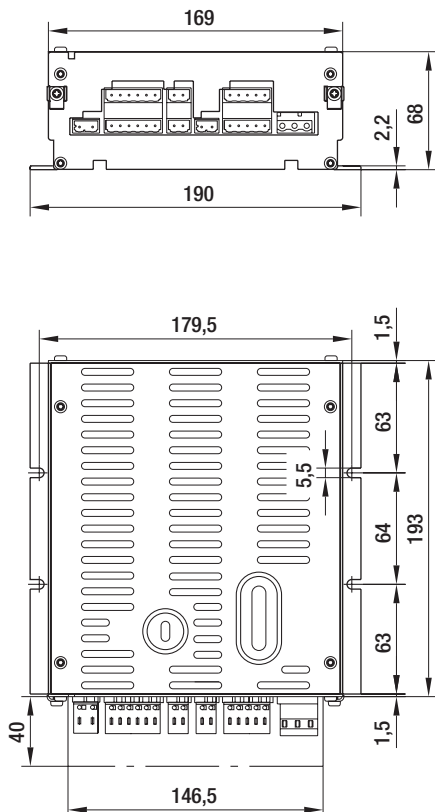

- **EMC / EMI:** Acc. to EN 50155 and EN 50121
- **Legislation:** Low voltage directive 73/23/EEC, VDE 0160/EN 50178
- **Design:**
  - Motor output protected against short circuit phase to phase and conditionally phase to earth
  - 0-10 V input ( $R_i$ : 100 k $\Omega$ )
  - 0-10 V input ( $R_i$ : 100 k $\Omega$ ) for connection of external actual value input
  - RS485 interface (ebmBUS)
  - Floating alarm contact 250 VAC / 5A, during alarm, relay is released (low-active)
  - Wide voltage input for external controller enabling via RESET function
  - Tach output
  - LED for operation and alarm mode  
green: unit on  
red: alarm
  - Setting of minimum and maximum values via potentiometer
  - Operational modes (to be set via DIP switch):  
Open loop speed control  
Closed loop speed control  
Controlling external parameters
  - Direction of motor rotation reversible
- **Connectors for external electronics:**
  - KL1 2-pole connector; centreline 7.5; Co. Wago part no.: 231-202/026-000
  - KL2A 6-pole connector; centreline 5; Co. Wago part no.: 231-106/026-000
  - KL2B 6-pole connector; centreline 5; Co. Wago part no.: 231-106/026-000
  - KL3A 2-pole connector; centreline 5; Co. Wago part no.: 231-102/026-000
  - KL3B 2-pole connector; centreline 5; Co. Wago part no.: 231-102/026-000
  - KL4 2-pole connector; centreline 5; Co. Wago part no.: 231-102/026-000
  - KL5A 5-pole connector; centreline 5; Co. Wago part no.: 231-105/026-000
  - KL5B 5-pole connector; centreline 5; Co. Wago part no.: 231-105/026-000
  - KL6 3-pole connector; centreline 7.5; Co. Wago part no.: 731-603

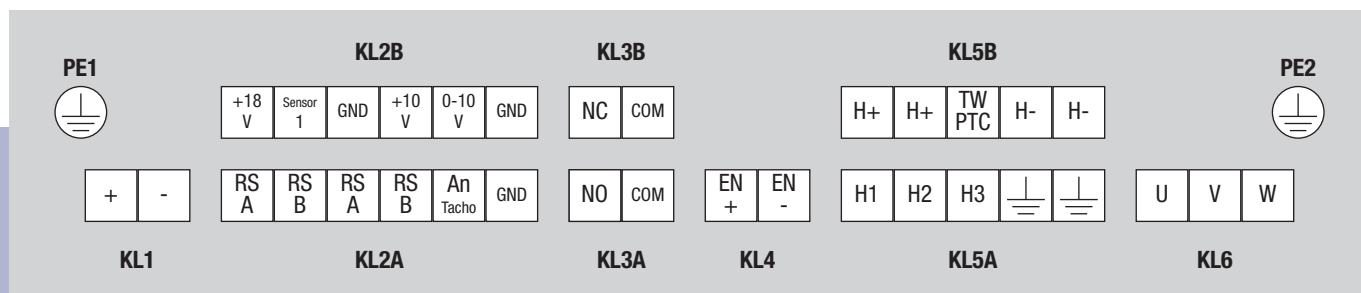

Connector	Connection	Assignment / function
PE1		Ground connection
PE2		Ground connection
KL1	+	110 VDC
	-	110 VDC
KL2A	RS A	Interface connection RS A
	RS B	Interface connection RS B
	RS A	Interface connection RS A
	RS B	Interface connection RS B
	An, Tacho	Tach output, open collector
	GND	Reference KL2 (for KL2 only)
KL2B	+18 V	+18 V (non-stabilised, +20%, 20 mA) for supplying external sensors
	Sensor 1	Input for external sensor, Ri = 100 kΩ
	GND	Reference KL2 (for KL2 only)
	+10 V	+10 V (stabilised +/- 3 %, 25 mA)
	0-10 V	Input for set value 0 - 10 V, Ri = 100 kΩ
	GND	Reference KL2 (for KL2 only)

Connector	Connection	Assignment / function
KL3A	NO	Relay contact for alarm, make for failure
	COM	Relay contact for alarm
KL3B	NC	Relay contact for alarm, break for failure
	COM	Relay contact for alarm
KL4	EN +	Enable input via RESET function
	EN -	Enable input via RESET function
KL5A	H1	Hall-sensor 1
	H2	Hall-sensor 2
	H3	Hall-sensor 3
	⊥	Shielding connection
	⊥	Shielding connection
KL5B	H+	Power supply for hall-sensors (+)
	H+	Power supply for hall-sensors (+)
	TW / PTC	Thermal switch or PTC connection
	H-	Power supply for hall-sensors (-)
KL6	H-	Power supply for hall-sensors (-)
	U	Motor winding U
	V	Motor winding V
	W	Motor winding W

# Temperature sensor



Nominal data	Nominal voltage	Current draw	Output voltage	Output current	Output impedance	Temperature measuring range	Mass
Part no.	VDC	mA	VDC	mA	k $\Omega$	$^{\circ}\text{C}$	kg
50005-1-0174	15-30	10	0-10	1.0	1.1	-20 to +80	0.02

subject to alterations

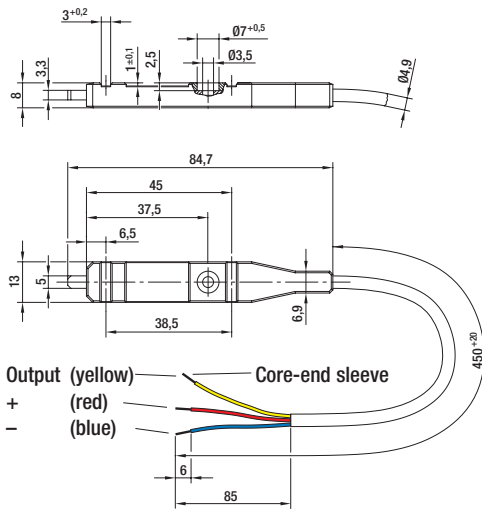

## - Electr. connection:

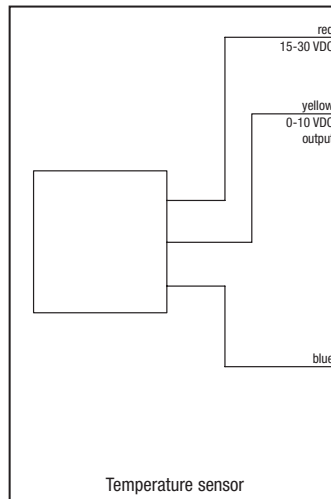

## - Output voltage depending on temperature:

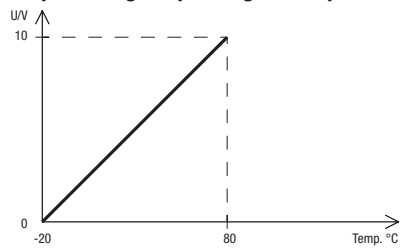

Tolerance  $\pm 3$  K

# Temperature control module



Nominal data	Nominal voltage	Current draw	Output voltage	Output current	Output impedance	Temperature control range	Mass
Part no.	VDC	mA	VDC	mA	kΩ	°C	kg
50002-1-0174	18-60	10	2-10	0.1	6.8	+30 to +55	0.02
50003-1-0174	18-60	10	0-10	0.1	6.8	+10 to +45	0.02

subject to alterations

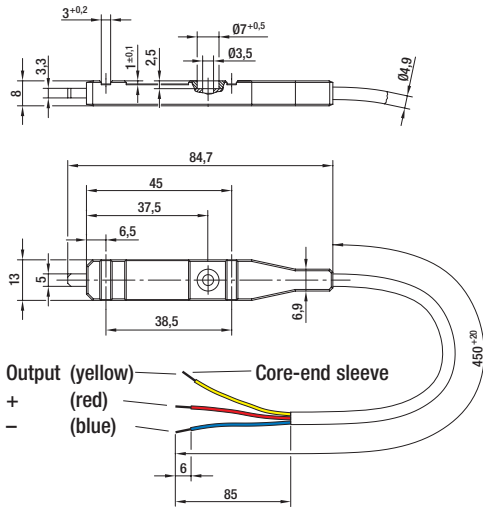

## - Electr. connection:

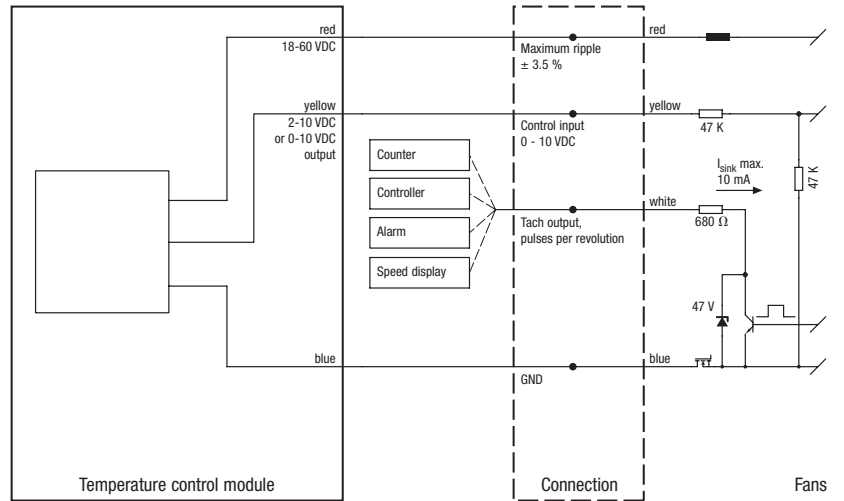

## - Control function: Both designs have "cooling" as control function

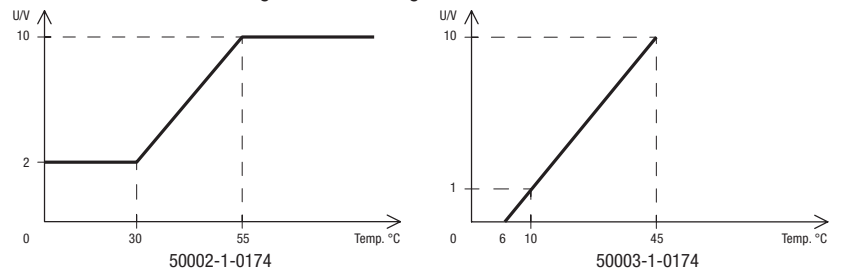

Tolerance ±3 K

# Pressure control with integrated pressure sensor



- **Functions:** Integrated PID controller, day/night/linear set point preset, integrated set point potentiometer for day and night, external set point preset via potentiometer
- **Pressure sensor:** 0-500 Pa, bursting strength 200 mbar, for non-aggressive gaseous media
- **Type of protection:** IP 55

Nominal data	Nominal voltage range	Frequency	Nominal voltage, alternative	Pressure control range	Perm. amb. temp.
Type	VAC	Hz	VDC	Pa	°C
CCC 000-AC04 -01	1~ 100-277	50/60	20 @ 50 mA	50-500	-25 to +60

subject to alterations

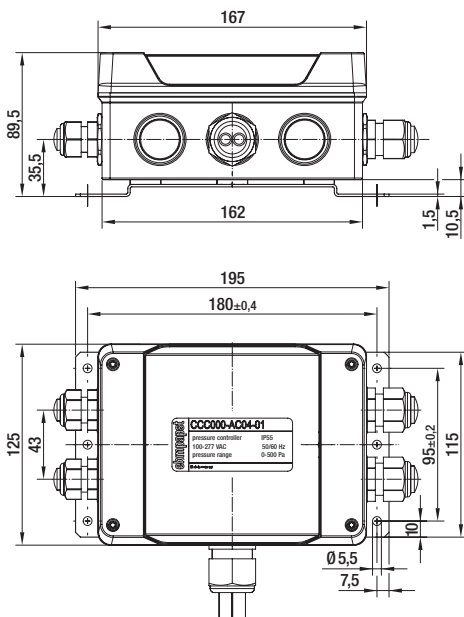

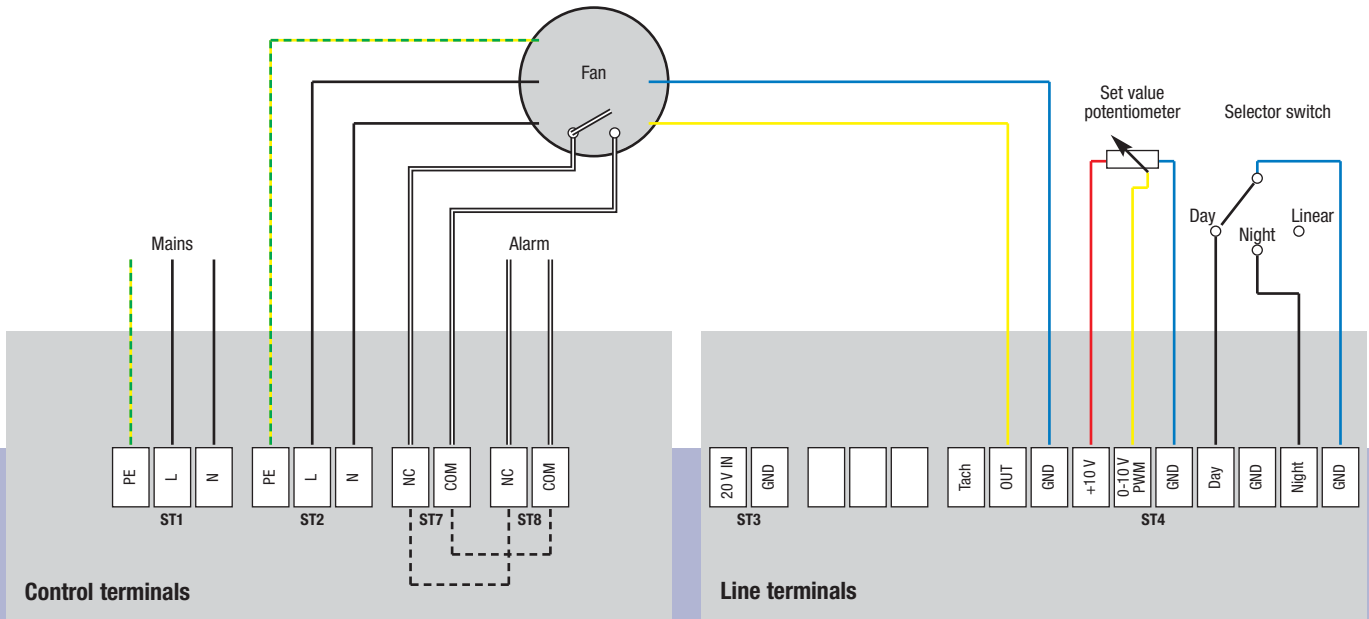

Connector	Connection	Assignment / function
ST1	PE	Protective earth
	L	Mains 50/60 Hz, phase
	N	Mains 50/60 Hz, neutral
ST2	PE	Protective earth
	L	Mains 50/60 Hz, phase
	N	Mains 50/60 Hz, neutral
ST7	NC	Relay contact for alarm, break for failure
	COM	Relay contact for alarm
ST8	NC	Relay contact for alarm, break for failure
	COM	Relay contact for alarm

Connector	Connection	Assignment / function
ST3	20 V IN	DC voltage supply (optional), with reverse polarity protection
	GND	GND
ST4	Tach	Tach output from fan
	OUT	Control voltage for fan, 0-10 V
	GND	GND
	+10 V	Set value potentiometer, supply 10 V (-10 %), 10 mA
	0-10 V PWM	Set value potentiometer
	GND	Set value potentiometer
	Day	Selector switch terminal
	GND	Selector switch terminal
	Night	Selector switch terminal
GND	Selector switch terminal	

# Selection module for 3 speeds



- **General remarks:** Using an external selector switch, one of three preset speeds can be chosen. Presetting is done via one integrated potentiometer each.
- **Material:** Plastics
- **Type of protection:** IP 20

## Type

CBC 000-AE04 -01

subject to alterations

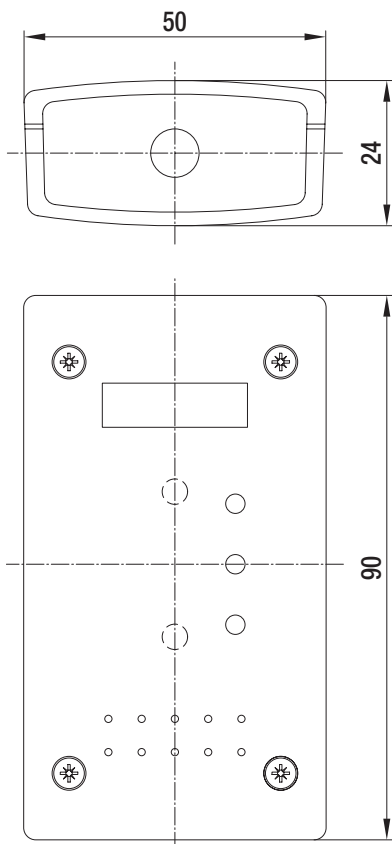



- Electr. connection:

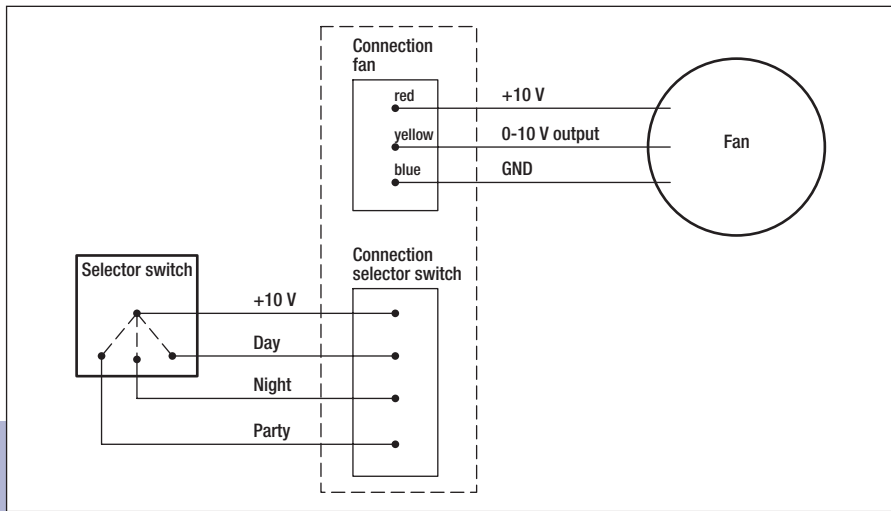

# Interface converter RS232 - RS485

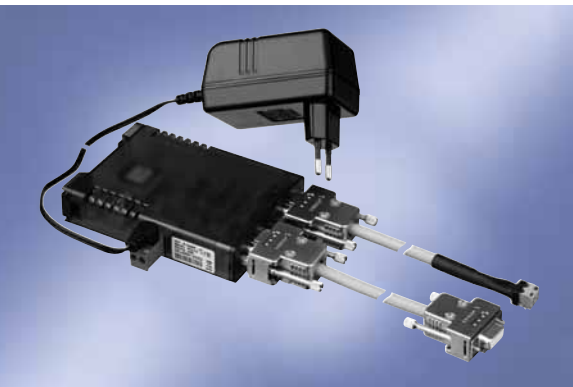

- **General remarks:** This interface converter permits bi-directional connection of RS232 devices (laptop or PC) with ebmBUS devices (electronic commutation units with RS485 interface)
- **Safety:** Electrical insulation between the RS232 and RS485 side is provided
- **Material:** Plastic housing for standard rail mounting according to DIN EN 50022-35
- **Status display:** Via LEDs  
green: supply voltage OK  
red: data exchange

Nominal data		Nominal voltage power supply	Supply voltage	Current draw at no-load operation	Mass (incl. PS)
Part no.	VAC	VAC / VDC	mA	kg	
21487-1-0174	1~ 230	12-24	150	0.4	

subject to alterations

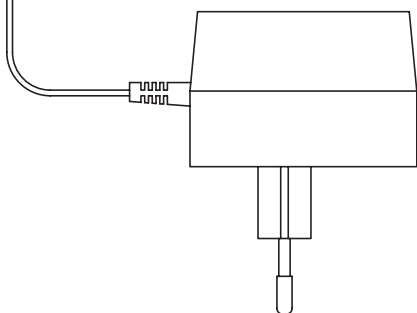
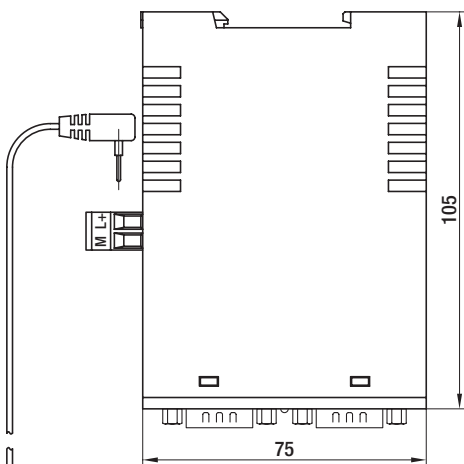
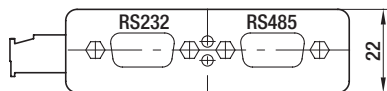

- **Mode of operation:** RS485 2-wire mode with echo and automatic control
- **Galvanic insulation:** Min. 1kV insulation voltage between RS232 and RS485 interfaces and between power supply and interfaces
- **ESD immunity:** Up to 15 kV (acc. to IEC 801-2, Stage 4)
- **Delivery scope:**
  - Interface converter
  - Supply plug unit (230 VAC / 12 VDC, 500 mA)
  - Adaptor leads with 2 x 9-pole SUB-D sockets
  - Adaptor leads with 9-pole SUB-D socket
  - Screw terminal RS485

# Interface converter RS232 - RS485



- **General remarks:** This interface converter permits bi-directional connection of RS232 devices (laptop / PDA) with ebmBUS devices (electronic commutation units with RS485 interface). Power supplied by RS232 of the laptop / PDA.
- **Material:** Plastic housing
- **Status display:** Via LEDs
  - PWR: Power supply
  - TXD: Data transfer (send)
  - RXD: Data transfer (receive)

Nominal data		Mass
Part no.	kg	
21495-2-0174	0.1	

subject to alterations

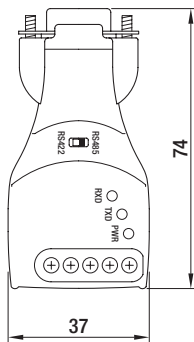
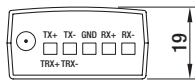

- **Mode of operation:** RS485 2-wire mode with echo and automatic control
- **Delivery scope:** Interface converter, English-language operating manual
- **Electrical terminals:** Screw terminal, TRX+ = RSA, TRX- = RSB

# RS485 repeater

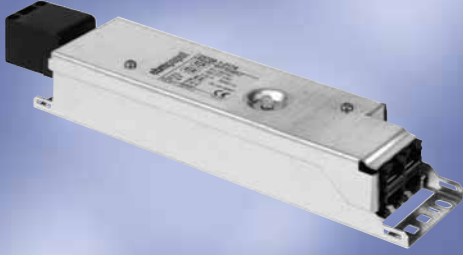

- **General remarks:** The physical RS485 repeater is used for the connection of two segments on an RS485 basis. It can split a segment with network bus wires that are too long, or with too many nodes into two smaller, standardised units. A maximum of 31 nodes can be connected to the repeater.
- **Installation:** The repeater housing is mounted on the wall or in the cable duct with two screws (Ø 4 mm) or with cable ties.
- **Material:** Housing made of galvanised sheet steel
- **Type of protection:** IP 20 according to DIN EN 60529

## Nominal data

Part no.	Supply voltage VAC	Frequency Hz	Power input VA	Perm. operating temp. °C	Perm. storage temp. °C	Mass kg
25708-1-0174	1~ 200-277	50/60	< 3	0 to +50	-20 to +70	0.3

subject to alterations

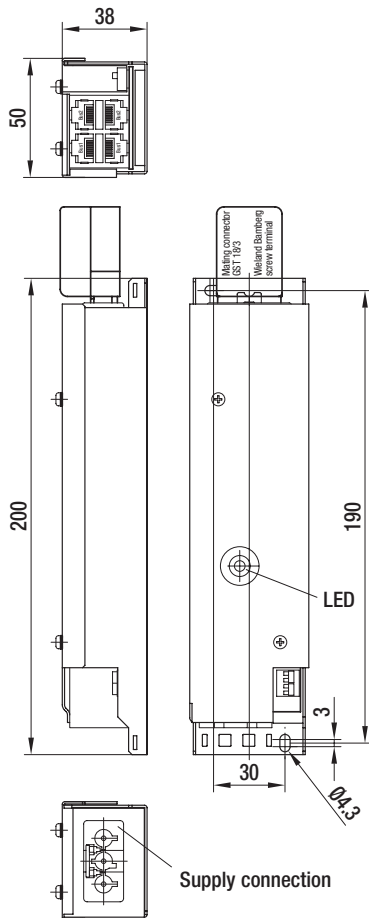

- **Type of transceiver:** 2 x ANSI standard RS485 transceiver
- **Galvanic insulation:** Operating insulation 500 V between both channels
- **Network connection:** Screw terminals
- **Mains connection:** Wieland connector GST 18/3 (part of delivery)
- **Pin configuration of network:**

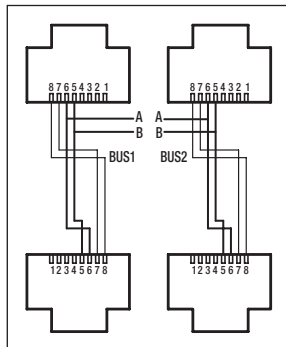

Pin No.	Assignment / function
1 - 4	not assigned
5	Connection RS485, line B
6	Connection RS485, line B
7, 8	not assigned (each looped through within BUS1 and BUS2)

## RS485 terminal box with lead connections

for centrifugal fans with EC motor size 084 (ebmBUS, RS485)



- **General remarks:** RS485 terminal box with
  - 2x RJ45 sockets for ebmBUS
  - ebmBUS line with Molex Mini-Fit female connector for connection to the motor
  - 3-pole 4-pin unit connector with AMP Mate-N-Lock female connector to connect to motor
  - Mode of operation display (LED2 green) and alarm display (LED 1 red)
- **Delivery scope:**
  - Terminal Box
  - Supply line (800 mm)
  - ebmBUS line (800 mm)
- **Material:** ABS (fire rating V0 according to UL)

### Part no.

54002-4-1040

subject to alterations

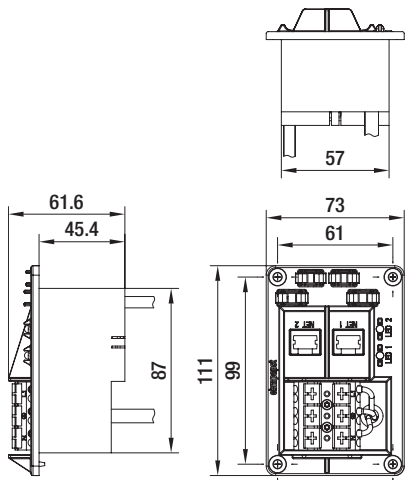

### Mounting dimensions

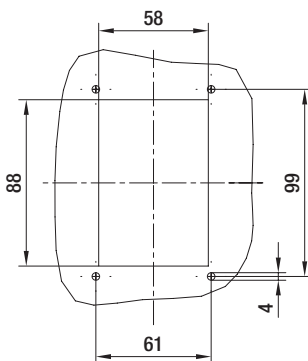

### - Pin configuration of supply lead:

Colour	Assignment / function
green/yellow	PE
black 2	N
black 1	L

### - Pin configuration of ebmBUS lead:

Colour	Assignment / function
yellow	RS A
white	RS B
red	Operation: +15 V Alarm: 0 V
blue	Operation: 0 V Alarm: +15 V

### - Pin configuration of RJ45 sockets:

Pin No.	Assignment / function
5	RS B
6	RS A

# Hand-held control terminal



- **General remarks:** Terminal to control networked fans and to set their parameters; RS485 (ebmBUS)
- **Type of protection:** IP 20 (acc. to DIN EN 60529)
- **Protection class:** III
- **Display:** Plain text LCD, 2x8 characters
- **Accumulator and charging electronics:** 2 x round cell R6 DIN 40863 NiMH 1,500 mAh, operating time approx. 40 hrs, standby time approx. 100 days, charging time max. 4 hrs.
- **Parts included in delivery:** Hand-held control terminal, power supply and accumulator unit, BUS cable, 2 x round cell R6 NiMH 1,500 mAh

Nominal data	Nominal voltage range power supply	Frequency	Supply voltage	Perm. amb. temp.	Perm. storage temp.	Mass
Type	VAC	Hz	VDC	°C	°C	kg
<b>CBC 000-AB06 -01</b>	1~ 100-240	50/60	12	0 to +45	-20 to +65	0.4

subject to alterations

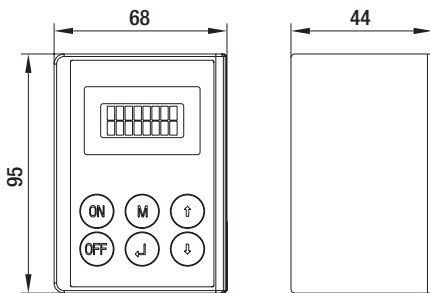



# Speed setting device

with housing



- **Material:** Housing made of plastic
- **Type of protection:** IP 54
- **Design:** The speed setting device can be operated with the entire range of ebm-papst EC fans. It is supplied with current via the fan's DC output and supplies a 0-10 V signal that allows infinitely variable open loop speed control. The control also permits fan speed measurement using a multimeter equipped with a frequency meter (for which a tach output is given from the fan).
- **Cable inputs:** 4 x M16 or M20
- **Mounting holes:** Suitable for 4 mm mounts

Nominal data	Supply voltage	Max. current draw	Resistance	Perm. amb. temp.	Mass
Type	VDC	mA	kΩ	°C	kg
CLC 000-AE04 -01	10	1.1	0-10 Lin	50	0.10

subject to alterations

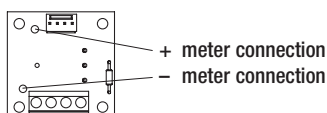
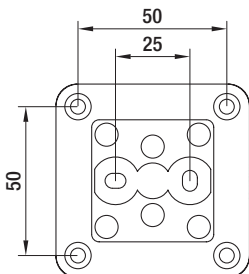
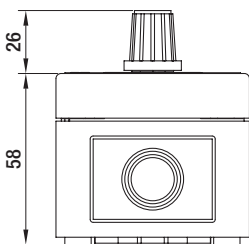
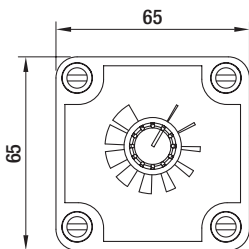

- **Speed measurement:** Connect a frequency meter to the connection points (labelled + and -) on the PCB board. The fan has an output of 1 pulse per revolution, so that the measured frequency can be converted into rpm using the following equation:

$$\text{rpm} = \text{frequency (Hz)} \times 60$$

- **Comment:**
  - A single controller can be used to control multiple fans with the same speed setting.
  - The connection to the controller is made using four screw connections or one Molex connection (adaptor lead available).
  - If the tach cable is required, this device can only be connected to one fan. Note that in rare operating cases, it is possible that permanent connection of the tach cable can cause a slight decrease in the maximum speed.



- Electr. connection:

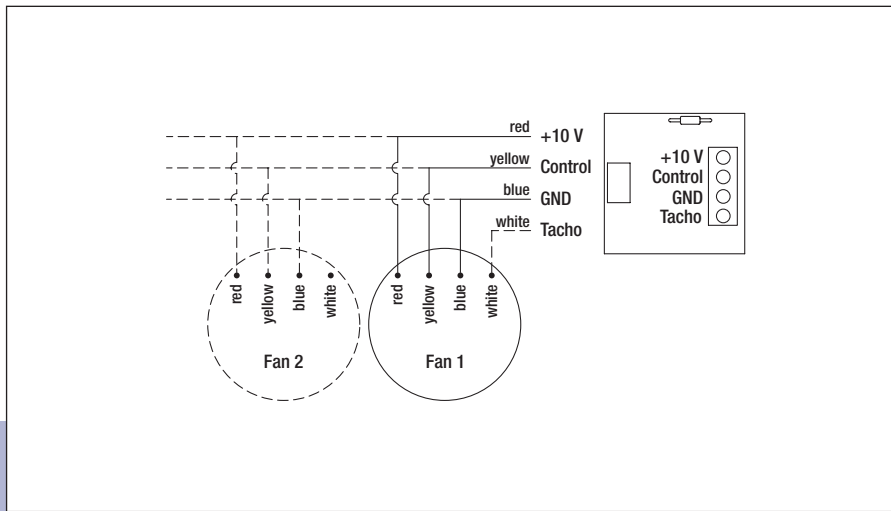

# Speed setting device

without housing



- **Design:** The speed setting device can be operated with the entire range of ebm-papst EC fans. It is supplied with current via the fan's DC output and supplies a 0-10 V signal that allows infinitely variable open loop speed control. The control also permits fan speed measurement using a multimeter equipped with a frequency meter (for which a tach output is given from the fan).
- **Mounting hole:** 10 mm

Nominal data	Supply voltage	Max. current draw	Resistance	Perm. amb. temp.	Mass
Type	VDC	mA	kΩ	°C	kg
CLC 000-AD04 -01	10	1.1	0-10 Lin	50	0.05

subject to alterations

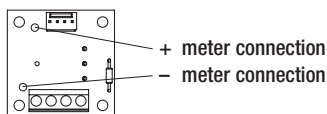
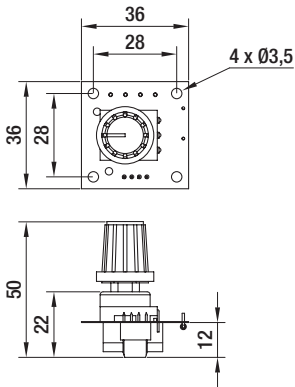

- **Speed measurement:** Connect a frequency meter to the connection points (labelled + and -) on the PCB board. The fan has an output of 1 pulse per revolution, so that the measured frequency can be converted into rpm using the following equation:

$$\text{rpm} = \text{frequency (Hz)} \times 60$$

- **Comment:**

- A single controller can be used to control multiple fans with the same speed setting.
- The connection to the controller is made using four screw connections or one Molex connection (adaptor lead available).
- If the tach cable is required, this device can only be connected to one fan. Note that in rare operating cases, it is possible that permanent connection of the tach cable can cause a slight decrease in the maximum speed.

- Electr. connection:

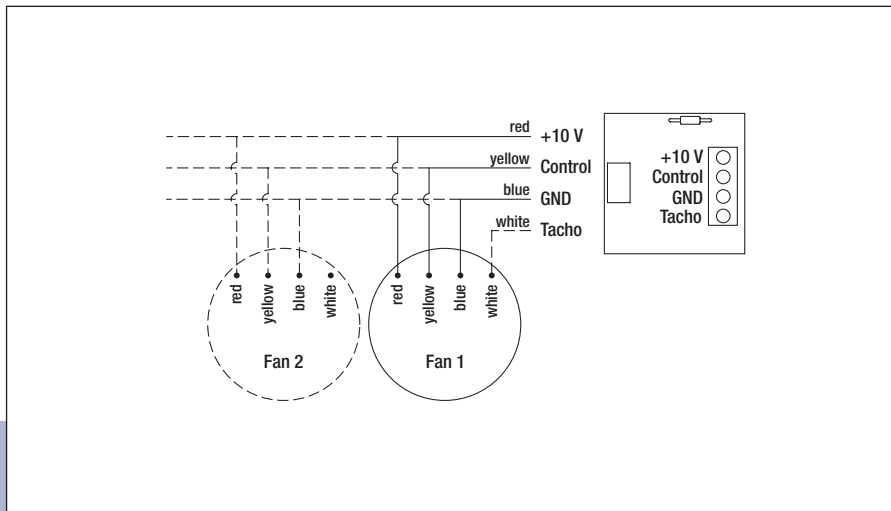

# LISA

Control software for EC-SYSTEMS

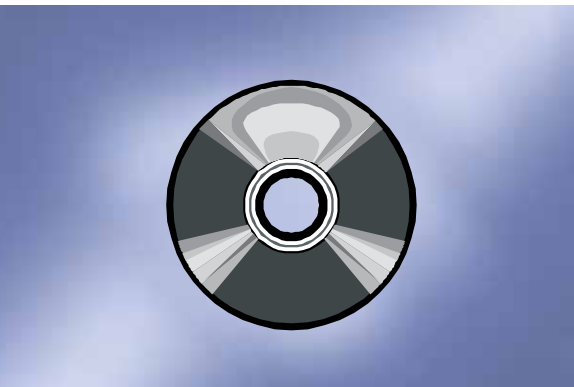

- **Version:** LISA 5.1
- **Features:**
  - Individual control and monitoring of 7,905 fans
  - Group-oriented arrangement of the fans
  - Level 1: Overview display for 10 floors
  - Level 2: Overview display for 255 groups within a floor
  - Level 3: Overview display for 31 fans within a group
  - Broadcast command for one group or all fans
  - Speed, temperature or pressure control
  - Error message

Part no.

25711-2-0199

subject to alterations

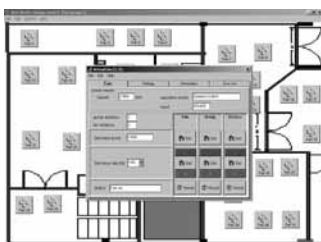
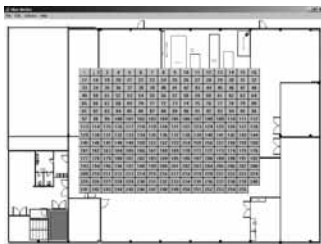

- **Suitable for:** EC motors and electronics with ebmBUS
- **System requirements:** Windows 2000 / XP

# Fan Control

Control software & accessories for Pocket PCs / PDAs

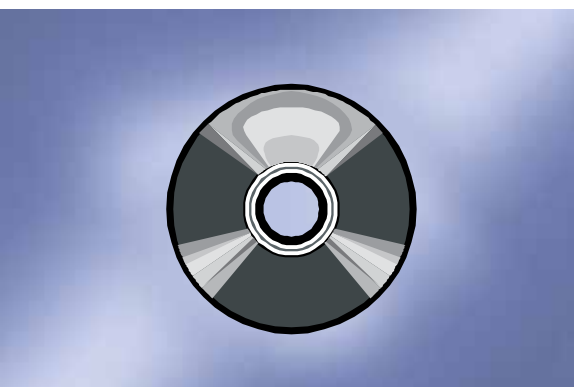

- **Version:** Fan Control 1.00
- **Features:**
  - Managing up to 31 fans
  - Setting pre-set values and indicating actual values
  - Setting parameters for PID control
  - Setting fan address
  - Setting mode of operation (heating/cooling)
  - Alarm diagnosis
  - Language selection for user interface

Part no.

21500-1-0174

subject to alterations

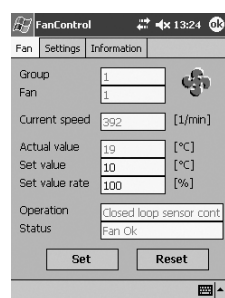

Set and actual values

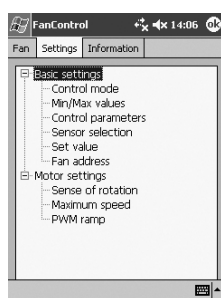

Mode of operation

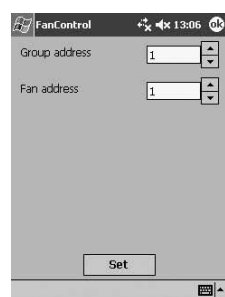

Fan address

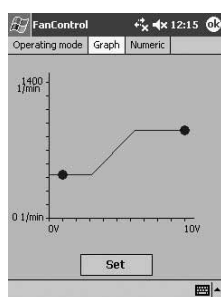

Graphic setting

- **Delivery scope:** Installation-CD, interface converter (RS232-RS485), BUS cable, installation instruction and detailed manual (PDF). The Pocket PC / PDA and compatible serial communication cables are not included in the scope of delivery.
- **Suitable for:** EC motors and electronics with ebmBUS
- **System requirements:** Pocket PC / PDA with Windows Mobile 5.0, RS232 interface, and serial communication cable.
- **Compatible Pocket PCs / PDAs:** (as of 2006-09-14)

- Hewlett-Packard rx1950
- Hewlett-Packard hx2190
- Fujitsu-Siemens Pocket Loox C550
- Dell Axim x51v (624 MHz)

Refer to our website at [www.ebmpapst.com/downloads](http://www.ebmpapst.com/downloads) for a continuously updated list of approved Pocket PCs / PDAs along with the suitable serial communication cables.

# HMS controller

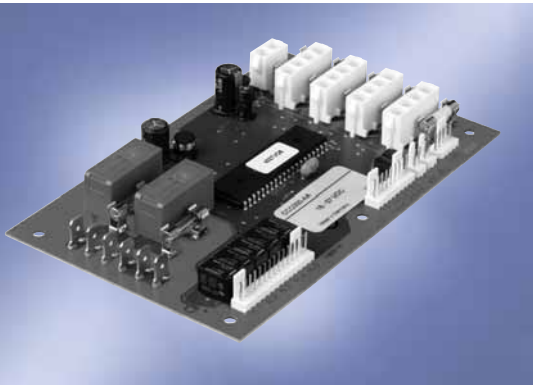

- **General remarks:** The HMS controller is governed by a microprocessor and is specifically designed for Heat Management Systems (= HMS). This controller allows for an almost limitless programming variety as regards customer-specific fan speed / temperature profiles. Moreover, this controller offers a multitude of the most diverse alarm configurations.

Our HMS controller has been specially designed and adjusted to the product range of ebm-papst in Mulfingen. Thus, any size of our fans or blowers can be used. The most diverse of applications needing temperature-dependent control are possible. Among these are applications in telecommunication and the IT industry, in refrigeration and air-conditioning as well as in specific industrial plants and systems.

Nominal data	Supply voltage	Power input <sup>(1)</sup> , max.	Power input <sup>(2)</sup> , max.	Current draw <sup>(1)</sup> max.	Perm. amb. temp.	Mass
Type	VDC	W	W	A	°C	kg
CCC 000-AA05 -03	16-57	10	130	0.175	-40 to +70	0.15

subject to alterations

(1) without fans (2) per fan at nominal voltage

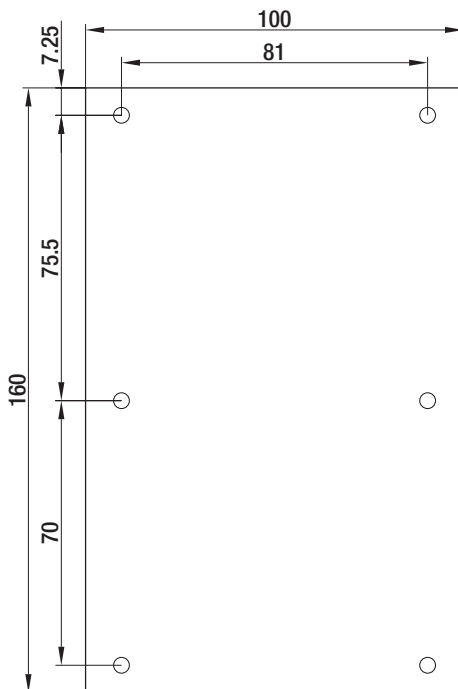

## Features:

- 4 fan speed / temperature characteristics that can be programmed independently of each other
- 2 programmable no-frost relays for connecting 115 / 230 VAC heating devices
- 5 programmable alarm relays (with time lag):
  - Temperature alarm (over / under-temperature)
  - Fan good / bad alarm programming
  - Temperature sensor alarm
  - Programmable depending on signal inputs
- 4 programmable status outputs (with time lag):
  - With "open collector" design to connect optical or acoustic displays / alarms
  - Each fan speed can be set individually
- 4 signal inputs for external switches / limit switches
- Connection of two independent temperature sensors (NTCs) possible
- RS232 interface galvanic insulated
- Selective protection of each fan
- Programming via Windows software (terminal program version 15 ff.: part no. 25710-2-0199)

## Requirements:

- Supply voltage of HMS controller: 16-57 VDC
- Fans with standard interface
  - 24 / 48 VDC fan voltage
  - PWM / linear control input (0-10 V)
  - Open collector tach output
- NTC with  $R_{25} = 33 \text{ k}\Omega$  (EPCOS type M 891/33k/J)
- System requirements: Windows 2000 / XP

## Safety:

According to EN 50178

- **EMC / EMI:** Interference immunity EN 61000, interference emission EN 50081-1

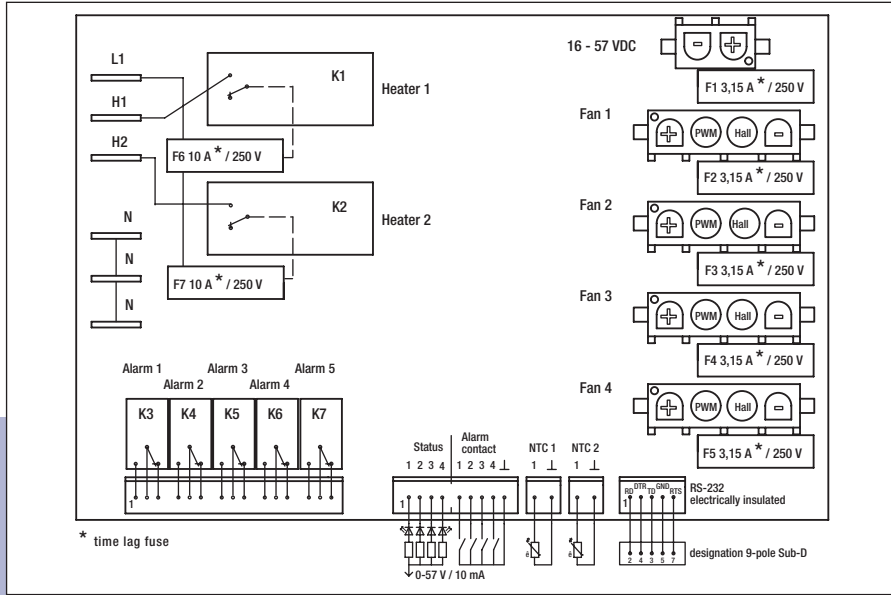

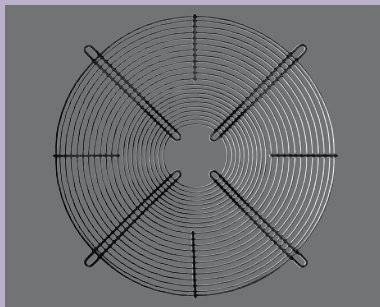
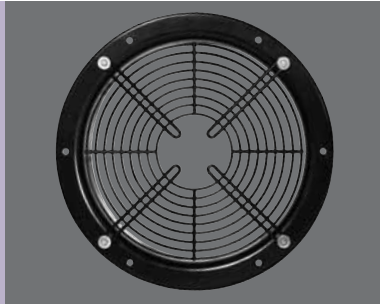



# Mouser Electronics

Authorized Distributor

Click to View Pricing, Inventory, Delivery & Lifecycle Information:

[ebm-papst:](#)

[CBC000-AB06-01](#) [21487-1-0174](#)