

8 7 6 5 4 3 2 1

**NOTES:**

1. **MOUNTING:** Mounts in a  $\phi .250 \pm .002$  [ $\phi 6.35\text{mm} \pm .05$ ] panel hole on .375 [9.5mm] centers. Panel thickness .063 [1.6mm] to .125 [3.17mm]. Panel hole should be deburred, but not chamfered.
2. **ASSEMBLY:** Insert lens through panel hole, and insert LED into lens.
3. **MATERIAL:** Polycarbonate, UL 94-V2  
GLO Series- Polycarbonate & Acrylic blend
4. U.S. & Foreign Pat. Issued & Pend.

REVISIONS				
ECN#	REV.	DESCRIPTION	DATE	INITIALS
	1	ADD GLO SERIES	1-6-09	JG
	001	REVISED PER ECR111009AZ01	4-23-10	SMU

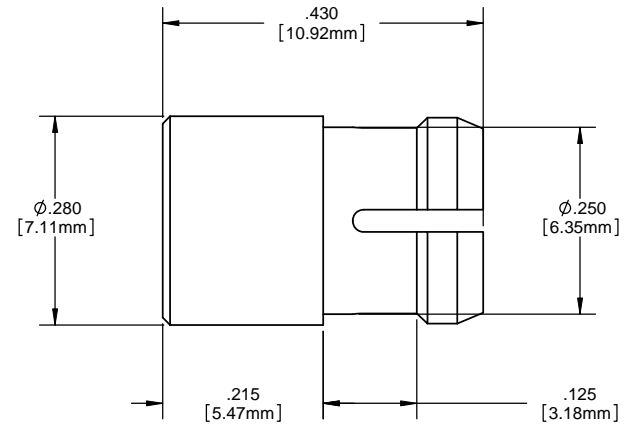
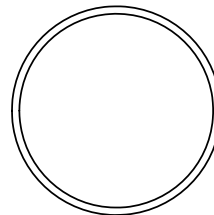
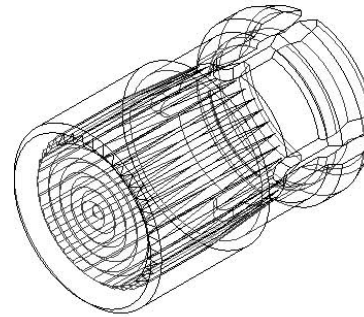

ORDERING CODE : **CLF 280 XXX**

MODEL

LENS COLOR	
RTP	RED TRANSPARENT
ATP	AMBER TRANSPARENT
GTP	GREEN TRANSPARENT
BTP	BLUE TRANSPARENT
YTP	YELLOW TRANSPARENT
CTP	CLEAR TRANSPARENT
GLO	WHITE TRANSLUCENT

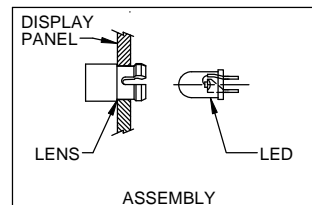

<small>UNLESS OTHERWISE SPECIFIED DIMENSIONS ARE IN INCHES</small> ANGLES DECIMALS $\pm 1^\circ$ .X $\pm .020$ .XXX $\pm .010$ FINISH XXX $\pm .005$ <small>BREAK ALL CORNERS AND SHARP EDGES 90 DEG</small>	<b>MATERIAL</b> POLYCARBONATE, UL 94-V2	<b>VISUAL COMMUNICATIONS COMPANY, INC.</b> <small>190 Bosstick Boulevard, Suite 101 San Marcos, CA 92069 USA            Phone (760) 560-1300 Fax (760) 560-1301 email vccsales@vccite.com</small>															
	<small>THIRD ANGLE PROJECTION</small> 	<b>FINISH</b> SEE NOTES	<b>TITLE: 5MM ROUND STANDARD HEIGHT FRESNEL LENS</b>														
<small>PROPRIETARY AND CONFIDENTIAL THE INFORMATION CONTAINED IN THIS DRAWING IS THE SOLE PROPERTY OF VISUAL COMMUNICATIONS COMPANY, INC. REPRODUCTION IN PART OR AS A WHOLE WITHOUT THE WRITTEN CONSENT OF VISUAL COMMUNICATIONS COMPANY, INC. IS PROHIBITED.</small>	<table border="1"> <tr> <th>APPROVAL</th> <th>DATE</th> </tr> <tr> <td>SMU</td> <td>4-23-10</td> </tr> </table>	APPROVAL	DATE	SMU	4-23-10	<table border="1"> <tr> <th>SIZE</th> <th>DWG. NO.</th> <th>REV</th> </tr> <tr> <td><b>B</b></td> <td><b>CLF 280 XXX</b></td> <td><b>001</b></td> </tr> </table>	SIZE	DWG. NO.	REV	<b>B</b>	<b>CLF 280 XXX</b>	<b>001</b>	<table border="1"> <tr> <th>SCALE:</th> <th>SHEET</th> </tr> <tr> <td>1:1</td> <td>1 OF 1</td> </tr> </table>	SCALE:	SHEET	1:1	1 OF 1
APPROVAL	DATE																
SMU	4-23-10																
SIZE	DWG. NO.	REV															
<b>B</b>	<b>CLF 280 XXX</b>	<b>001</b>															
SCALE:	SHEET																
1:1	1 OF 1																
DRAWN: SMU 4-23-10 CHECKED: DZ 4-23-10 DO NOT SCALE DRAWING																	

8 7 6 5 4 3 2 1