

MLX91217 High Speed Current Sensor IC

Datasheet

1. Features and Benefits

- End-of-line programmable sensor
- Selectable analog ratiometric output
- Measurement range from ± 5 to ± 450 mT
- Wideband sensing: DC to 250kHz
- Very short response time (2 μ s)
- High linearity down to $\pm 0.2\%$ full scale
- Very low thermal drift
 - Offset drift (<5mV)
 - Sensitivity drift (<1%)
- Programmable output clamping levels
- Broken wire detection and diagnostics
- AEC-Q100 – Grade 0 Automotive Qualified
- RoHS compliant
- SIP4-VA package
- MSL-1

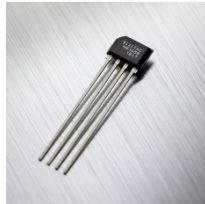

2. Application Examples

- High Voltage Traction Motor Inverter
- 48V Boost Recuperation Inverter
- DCDC Converter
- Smart Battery Junction Boxes
- Smart Fuse Overcurrent Detection

3. Description

The MLX91217 is a monolithic Hall-effect sensor which is sensitive to the flux density applied orthogonally to the IC surface. The sensor provides an analog output voltage proportional to the applied magnetic flux density.

The transfer characteristic of the MLX91217 is factory trimmed over temperature, and is programmable (offset, sensitivity, clamping, filtering) during end-of-line customer calibration. The output clamping levels and on-chip filtering

are also programmable as a function of application needs. With the 250kHz bandwidth and fast response time, it is particularly adapted for high speed applications such as inverters and converters where fast response time due to fast switching is required.

In a typical current sensing application, the sensor is used in combination with a ring shaped soft ferromagnetic core. This core is recommended to be laminated for high bandwidth applications. The MLX91217 is placed in a small air gap and the current conductor – a bus bar or a cable – is passed through the inner part of the ferromagnetic ring. On the one hand the ring concentrates and amplifies the magnetic flux seen by the sensor IC, and at the same time it attenuates external magnetic field disturbances.

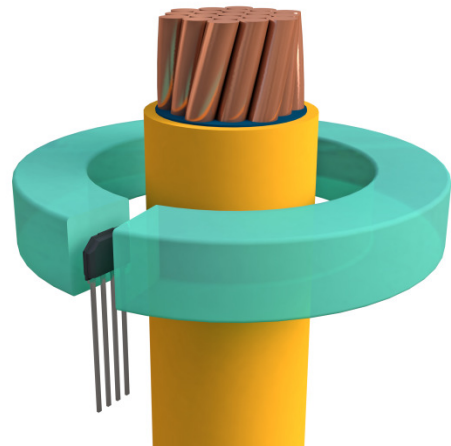

Figure 1. Typical Current Sensing Application

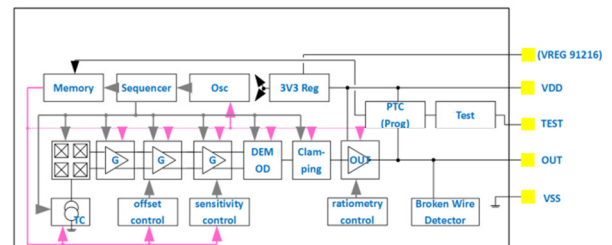

Figure 2. General Block Diagram

Contents

1. Features and Benefits.....	1
2. Application Examples.....	1
3. Description	1
4. Ordering Information	3
5. Functional Diagram	4
6. Glossary of Terms.....	4
7. Pin Definitions and Descriptions	4
8. Absolute Maximum Ratings	5
9. General Electrical Specifications	5
10. Magnetic specification.....	6
11. Analog output specification	7
11.1. Accuracy specifications	7
11.2. Timing specifications	7
12. Self-diagnostic	8
13. Recommended Application Diagram	8
14. Standard Information	9
15. ESD Precautions.....	9
16. Packaging information	10
16.1. Sensor active measurement direction.....	11
17. Contact.....	13
18. Disclaimer.....	13

4. Ordering Information

Product	Temperature	Package	Option Code	Packing Form	Typical Sensitivity
MLX91217	L	VA	ACA – 000	BU/CR	10mV/mT (prog: 5..150mV/mT)
MLX91217	L	VA	ACA – 001	BU/CR	15 mV/mT (prog: 5..150mV/mT)
MLX91217	L	VA	ACA – 003	BU/CR	9 mV/mT (prog: 5..150mV/mT)
MLX91217	L	VA	ACA – 005	BU/CR	13 mV/mT (prog: 5..150mV/mT)

Table 1: Available ordering codes.

Legend:

Temperature Code:	L: from -40°C to 150°C ambient temperature
Package Code:	“VA” for SIP4-VA package, refer to Chapter 16 for detailed drawings
Option Code:	ACA-x00: 10mV/mT sensitivity (5-150mV/mT programmable range) ACA-x01: 15mV/mT sensitivity (5-150mV/mT programmable range) ACA-x03: 9mV/mT sensitivity (5-150mV/mT programmable range) ACA-x05: 13mV/mT sensitivity (5-150mV/mT programmable range) ACA-0xx: Straight leg ACA-1xx: SMD style TFT4K1 ACA-2xx: 90deg 2x2x91.3 Bending-STD2
Packing Form:	“BU” for Bulk, “CR” for Carton Reel, radial taping, “CA” for Carton Reel, ammopack, “RE” for Plastic Reel.
Ordering Example:	“MLX91217LVA-ACA-005-CR” MLX91217 Conventional Hall current sensor in SIP4 VA package, temperature range -40°C to 150°C. Sensitivity 13mV/mT. Parts delivered in Carton Reel (Radial Taping)

8. Absolute Maximum Ratings

Parameter	Symbol	Value	Unit
Positive Supply Voltage (overvoltage)	V_{DD}	+10	V
Reverse Voltage Protection	$V_{S_{REV}}$	-0.3	V
Positive Output Voltage	V_{OUT}	+10	V
Output Current	I_{OUT}	+70	mA
Reverse Output Voltage	$V_{O_{REV}}$	-0.3	V
Reverse Output Current	$I_{O_{REV}}$	-50	mA
Operating Ambient Temperature Range	T_A	-40 to +150	°C
Storage Temperature Range	T_S	-55 to +165	°C
Magnetic Flux Density	B_{MAX}	±3	T
ESD – Human Body Model	ESD_{HBM}	2	kV

Table 4: Absolute maximum ratings

Exceeding the absolute maximum ratings may cause permanent damage. Exposure to absolute maximum-rated conditions for extended periods of time may affect device reliability.

9. General Electrical Specifications

Operating Parameters $T_A = -40$ to 150°C , $V_{DD} = 5V \pm 10\%$, unless otherwise specified.

Parameter	Symbol	Test Conditions	Min.	Typ.	Max.	Units
Nominal Supply Voltage	V_{DD}		4.5	5	5.5	V
Supply Current	I_{DD}	No OUT load		12.5	15	mA
		LOW_POWER_MODE=0 ¹ LOW_POWER_MODE=1		10	13	mA
Output Impedance	R_{OUT}	Normal Operation		1	5	Ω
Output Capacitive Load	C_L	OUT_MODE=0 ¹	2		10	nF
		OUT_MODE=1	10		47	nF
Output Resistive Load	R_L		10	25	200	kΩ
Output Short Circuit Current	I_{SHORT}	Output shorted to VDD – Permanent Output shorted to GND – Permanent		Not Destroyed		

¹ Default Factory Calibration

Parameter	Symbol	Test Conditions	Min.	Typ.	Max.	Units
Linear Output Range	VO _{LIN}	pull-down ≥ 10 kΩ	10		90	%V _{DD}
Diagnostic Band ²	DIAG	R _L ≥ 10kΩ, R _L ≤ 200 kΩ, V _{DD} =5V DIAG_LEVEL = 0	0		4	%V _{DD}
		DIAG_LEVEL = 1	96		100	%V _{DD}
BrokenGND Output Level ²		R _L ≥ 10kΩ, V _{DD} = 5V	96		100	%V _{DD}
BrokenVDD Output Level ²		R _L ≥ 10kΩ, V _{DD} = 5V	0		4	%V _{DD}
Under-voltage detection ²	V _{DD_UVD}	Detected Voltage (Low to High)	4.0		4.4	V
	V _{DD_UVH}	Hysteresis	0.00		0.15	V
Over-voltage detection 1 ²	V _{DD_OVD1}	Detected Voltage (Low to High)	6.7		7.4	V
	V _{DD_OVH1}	Hysteresis	0.37		0.66	V
Over-voltage detection 2 ²	V _{DD_OVD2}	Detected Voltage (Low to High)	8.4		9.3	V
	V _{DD_OVH2}	Hysteresis	0.32		0.68	V
Clamped Output Level	Clamp_lo0	CLAMP_LEVEL=0	5	6	7	%V _{DD}
	Clamp_hi0	CLAMP_LEVEL=0	92	93	94	%V _{DD}
	Clamp_lo1	CLAMP_LEVEL=1	5	6	7	%V _{DD}
	Clamp_hi1	CLAMP_LEVEL=1	93	94	95	%V _{DD}
	Clamp_lo2	CLAMP_LEVEL=2	7	8	9	%V _{DD}
	Clamp_hi2	CLAMP_LEVEL=2	91	92	93	%V _{DD}
	Clamp_lo3	CLAMP_LEVEL=3	9	10	11	%V _{DD}
	Clamp_hi3	CLAMP_LEVEL=3	89	90	91	%V _{DD}

Table 5: General electrical parameters

10. Magnetic specification

Operating Parameters T_A = -40 to 150°C, V_{DD} = 5V±10%, unless otherwise specified.

Parameter	Symbol	Test Conditions	Min	Typ	Max	Units
Operational Magnetic Field Range	B _{OP}		±15	±130	±450	mT
Linearity Error (Magnetic)	NL	V _{OUT} in [10%V _{DD} , 90%V _{DD}], T _A = 25°C			±0.4	%FS
		LOW_POWER_MODE=0 LOW_POWER_MODE=1			±0.2	%FS
Programmable Sensitivity	S		5	15	150	mV/mT
Sensitivity programming Resolution	S _{RES}	B = B _{OP}		0.1		%

Table 6: Magnetic specification

² Please refer to section 12 for more information on self-diagnostic modes.

11. Analog output specification

11.1. Accuracy specifications

Operating Parameters $T_A = -40$ to 150°C , $V_{DD} = 5V \pm 10\%$, unless otherwise specified.

Parameter	Symbol	Test Conditions	Min	Typ	Max	Units
Thermal Offset Drift	$\Delta^T V_{OQ}$	$T_A = -40$ to 125°C			± 5	mV
		$T_A = -40$ to 150°C			± 8	mV
Thermal Sensitivity Drift	$\Delta^T S$	$T_A = -40$ to 125°C			± 1.0	%S
		$T_A = -40$ to 150°C			± 1.2	%S
RMS Output Noise	N_{RMS}	Values for 50mV/mT sensitivity Scales with typical sensitivity of Table 1		10		mV _{RMS}
		NOISE_FILTER=0		7		mV _{RMS}
		NOISE_FILTER=1		5		mV _{RMS}
		NOISE_FILTER=2		3		mV _{RMS}
V_{OQ} Ratiometry	$\Delta^R V_{OQ}$	$V_{DD} = 5V \pm 5\%$, $V_{OQ} = 50\%V_{DD}$			± 0.4	% V_{OQ}
Sensitivity Ratiometry	$\Delta^R S$	$V_{DD} = 5V \pm 5\%$, $B = B_{OP}$			± 0.4	%S
Clamped output accuracy	CL_{ACC}				± 1	%V _{DD}

Table 6: Accuracy specifications – analog parameters

The accuracy specifications are defined for the factory calibrated sensitivity. The achievable accuracy is dependent on the user’s end-of-line calibration. For application notes on sensor programming and calibration, Resolution for offset and offset drift calibration is better than $0.02\%V_{DD}$. Trimming capability is higher than measurement accuracy. End-user calibration can therefore increase the accuracy of the system.

11.2. Timing specifications

Operating Parameters $T_A = -40$ to 150°C , $V_{DD} = 5V \pm 10\%$, unless otherwise specified.

Parameter	Symbol	Test Conditions	Min	Typ	Max	Units
Step Response Time	T_R	$C_L = 10\text{nF}$				
		NOISE_FILTER=0, LOW_POWER_MODE=0		2	3	μs
		NOISE_FILTER=0, LOW_POWER_MODE=1		3	4	μs
		NOISE_FILTER=1, LOW_POWER_MODE=0		3	4	μs
		NOISE_FILTER=1, LOW_POWER_MODE=1		5	6	μs
		NOISE_FILTER=2, LOW_POWER_MODE=0		4	5	μs
		NOISE_FILTER=2, LOW_POWER_MODE=1		6	7	μs
		NOISE_FILTER=3, LOW_POWER_MODE=0		8	9	μs
Power on Delay	T_{POD}	$V_{out} = 100\%$ of F.S.			1	ms
Ratiometry Cut-off Frequency	F_{RAT}			250		Hz

Table 7: Timing specifications of the high-speed analog output

12. Self-diagnostic

MLX91217 provides several self-diagnostic features, which prevent the IC from providing erroneous output signal in case of internal or external failure modes.

Error	Effect on Output	Remarks
Calibration data CRC Error	DIAG_LEVEL=0 → active pull-down to GND DIAG_LEVEL=1 → active pull-up to VDD	at power up and in normal mode
Power-On Delay	Pull-down to GND	1ms max followed by settling
Over-voltage Mode 1	Active pull-down to GND	
Over-voltage Mode 2	DIAG_LEVEL=0 → active pull-down to GND DIAG_LEVEL=1 → active pull-up to VDD	
Under-voltage Mode	DIAG_LEVEL=0 → active pull-down to GND DIAG_LEVEL=1 → active pull-up to VDD	Valid with enabled ratiometry (Default: RATIOEN = 1)
Broken OUT	Active pull-down to GND	
Broken GND	Output pulled up to VDD	IC is switched off
Broken VDD	Output pulled down to GND	IC is switched off

Table 8: Description of the self-diagnostic modes in MLX91217

13. Recommended Application Diagram

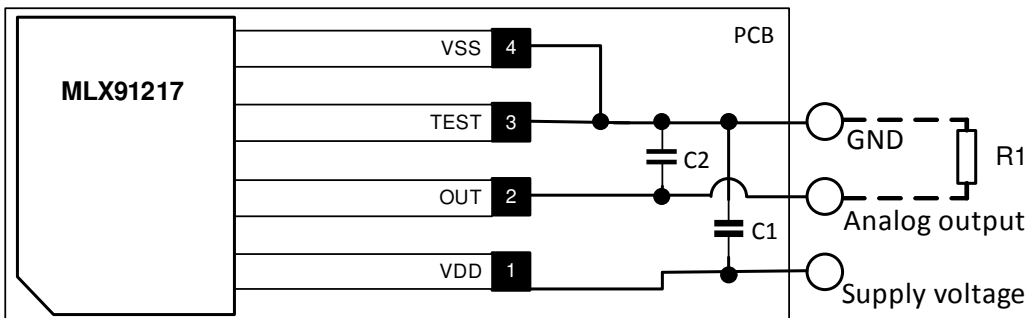

Figure 4: Application Diagram with external Pull-Down resistance

Part	Description	Value	Unit
C1	Supply capacitor, EMI, ESD	100	nF
C2	Decoupling, EMI, ESD, OUT_MODE=0	1-10	nF
	Decoupling, EMI, ESD, OUT_MODE=1	8-47	nF
R1	Pull down resistor	10-200	kΩ

Table 7: Resistor and capacitor values

14. Standard Information

Our products are classified and qualified regarding soldering technology, solderability and moisture sensitivity level according to standards in place in Semiconductor industry.

Reflow Soldering SMD's (Surface Mount Device)s)

- IPC/JEDEC J-STD-020
Moisture/Reflow Sensitivity Classification for Nonhermetic Solid State Surface Mount Devices (classification reflow profiles according to table 5-2)
- EIA/JEDEC JESD22-A113
Preconditioning of Nonhermetic Surface Mount Devices Prior to Reliability Testing (reflow profiles according to table 2)

Wave Soldering SMD's (Surface Mount Device)s) and THD's (Through Hole Device)s)

- EN60749-20
Resistance of plastic- encapsulated SMD's to combined effect of moisture and soldering heat
- EIA/JEDEC JESD22-B106 and EN60749-15
Resistance to soldering temperature for through-hole mounted devices

Iron Soldering THD's (Through Hole Device)s)

- EN60749-15
Resistance to soldering temperature for through-hole mounted devices

Solderability SMD's (Surface Mount Device)s) and THD's (Through Hole Device)s)

- EIA/JEDEC JESD22-B102 and EN60749-21
Solderability

For further details about test method references and for compliance verification of selected soldering method for product integration, Melexis recommends reviewing on our web site the General Guidelines [soldering recommendation](#). For all soldering technologies deviating from the one mentioned in above document (regarding peak temperature, temperature gradient, temperature profile etc), additional classification and qualification tests have to be agreed upon with Melexis.

For package technology embedding trim and form post-delivery capability, Melexis recommends to consult the dedicated trim&form recommendation application note: [lead trimming and forming recommendations](#).

Melexis is contributing to global environmental conservation by promoting **lead free** solutions. For more information on qualifications of **RoHS** compliant products (RoHS = European directive on the Restriction Of the use of certain Hazardous Substances) please visit the quality page on our website: <http://www.melexis.com/en/quality-environment>

15. ESD Precautions

Electronic semiconductor products are sensitive to Electro Static Discharge (ESD). Always observe Electro Static Discharge control procedures whenever handling semiconductor products.

16. Packaging information

16.1. VA Straight leg (0xx)

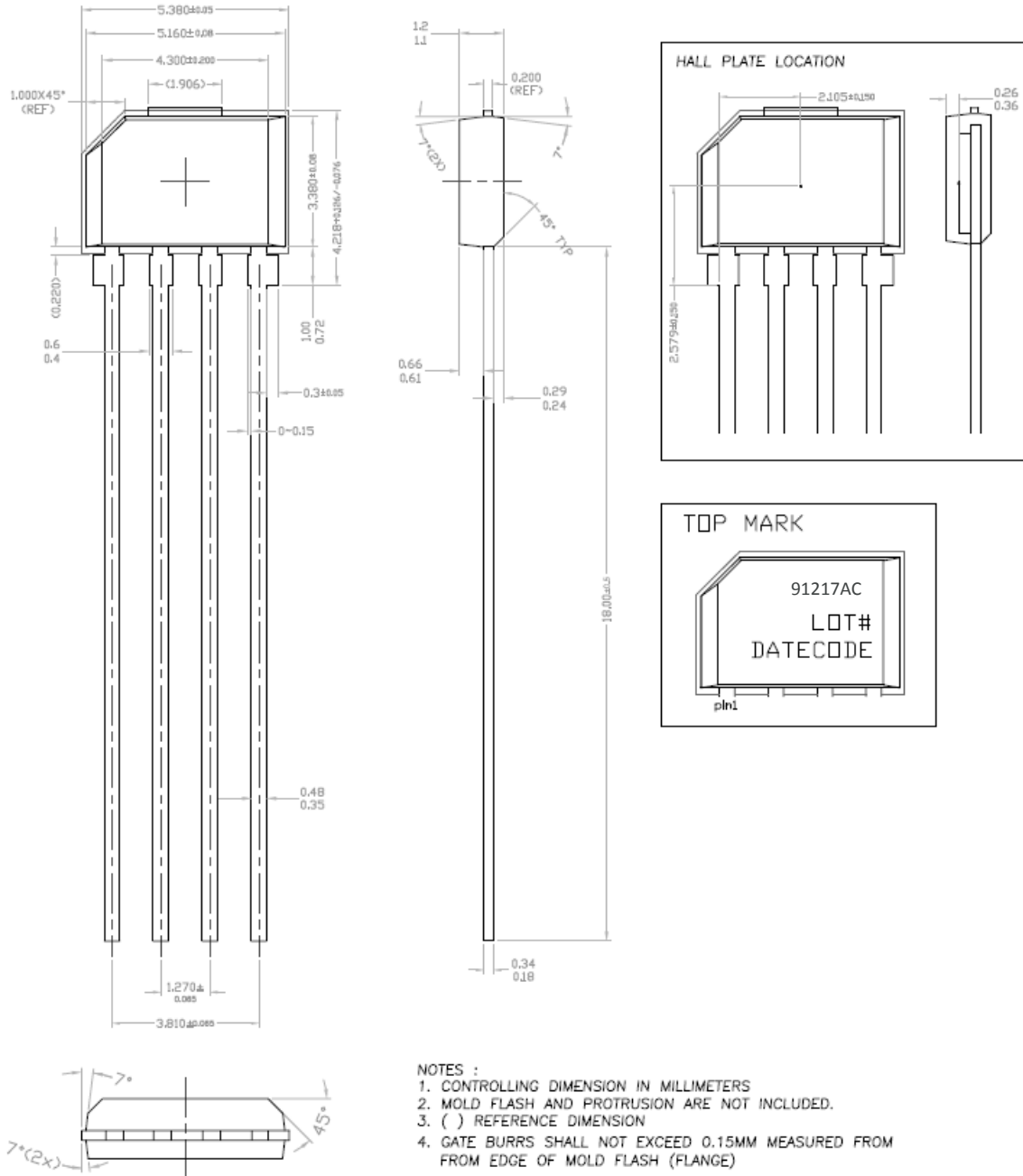
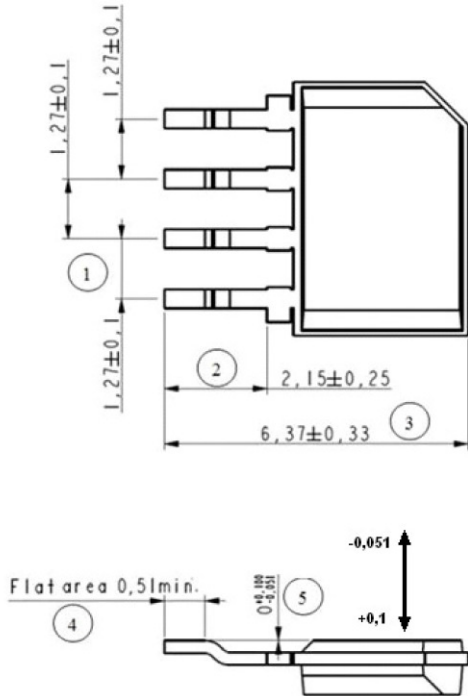

Figure 5. VA/SIP 4L (single in-line package) / 18mm lead length - Package Information

16.2. SMD style TFT4K1 (1xx)



Parameter				
Dim# 1 [mm]	Dim# 2 [mm]	Dim# 3 [mm]	Dim# 4 [mm]	Dim# 5 [mm]
1.27 +/- 0.10	2.15 +/- 0.25	6.37 +/- 0.33	min. 0.51	0 -0.051/+0.10

16.3. 90° 2x2x91.3 Bending-STD2 (2xx)

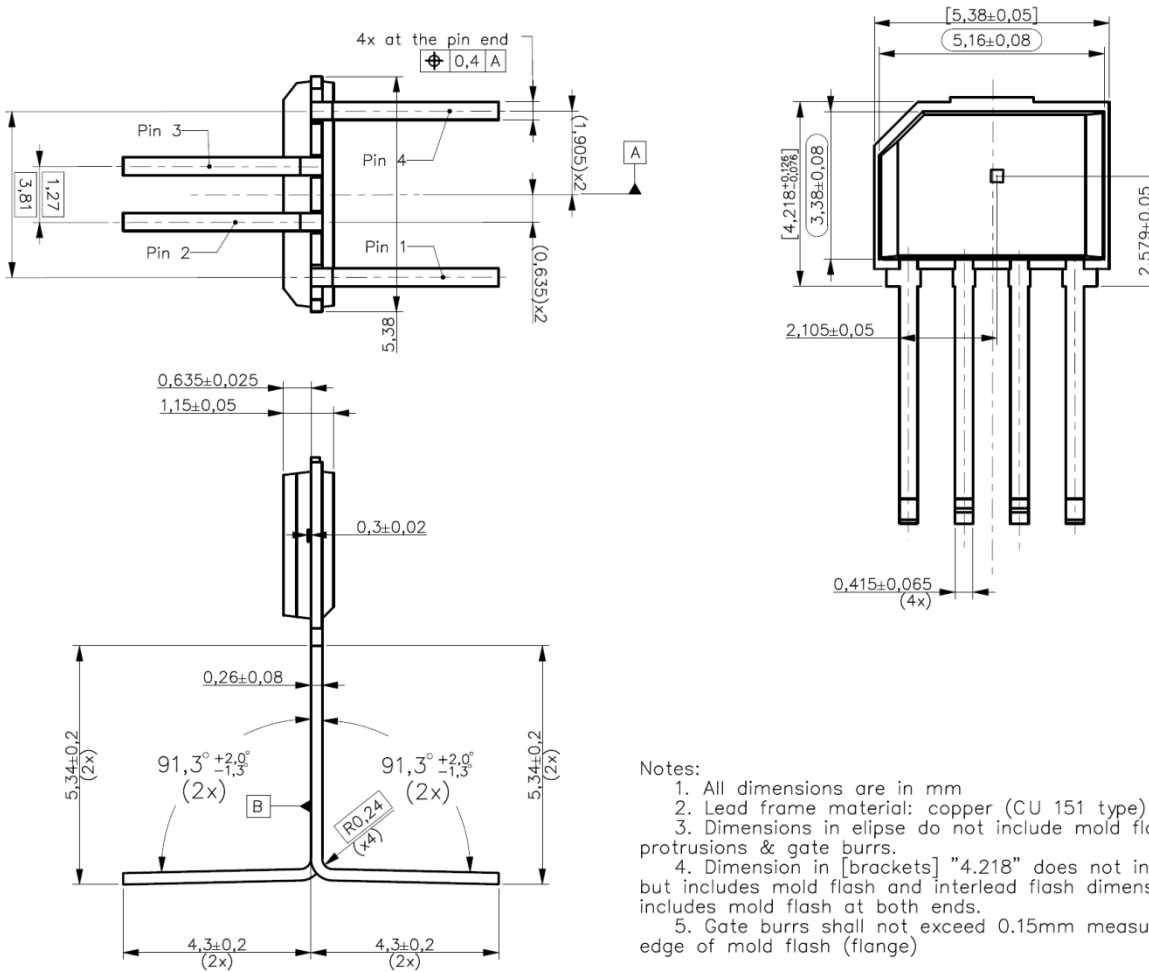

16.4. Sensor active measurement direction

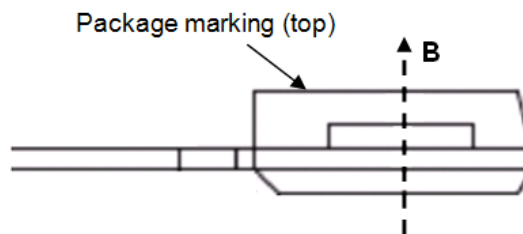

Figure 6. VA/SIP 4L Package. Sensor's active measurement direction

17. Contact

For the latest version of this document, go to our website at www.melexis.com.

For additional information, please contact our Direct Sales team and get help for your specific needs:

Europe, Africa	Telephone: +32 13 67 04 95
	Email : sales_europe@melexis.com
Americas	Telephone: +1 603 223 2362
	Email : sales_usa@melexis.com
Asia	Email : sales_asia@melexis.com

18. Disclaimer

The information furnished by Melexis herein ("Information") is believed to be correct and accurate. Melexis disclaims (i) any and all liability in connection with or arising out of the furnishing, performance or use of the technical data or use of the product(s) as described herein ("Product") (ii) any and all liability, including without limitation, special, consequential or incidental damages, and (iii) any and all warranties, express, statutory, implied, or by description, including warranties of fitness for particular purpose, non-infringement and merchantability. No obligation or liability shall arise or flow out of Melexis' rendering of technical or other services.

The Information is provided "as is" and Melexis reserves the right to change the Information at any time and without notice. Therefore, before placing orders and/or prior to designing the Product into a system, users or any third party should obtain the latest version of the relevant information to verify that the information being relied upon is current. Users or any third party must further determine the suitability of the Product for its application, including the level of reliability required and determine whether it is fit for a particular purpose.

The Information is proprietary and/or confidential information of Melexis and the use thereof or anything described by the Information does not grant, explicitly or implicitly, to any party any patent rights, licenses, or any other intellectual property rights.

This document as well as the Product(s) may be subject to export control regulations. Please be aware that export might require a prior authorization from competent authorities. The Product(s) are intended for use in normal commercial applications. Unless otherwise agreed upon in writing, the Product(s) are not designed, authorized or warranted to be suitable in applications requiring extended temperature range and/or unusual environmental requirements. High reliability applications, such as medical life-support or life-sustaining equipment are specifically not recommended by Melexis.

The Product(s) may not be used for the following applications subject to export control regulations: the development, production, processing, operation, maintenance, storage, recognition or proliferation of 1) chemical, biological or nuclear weapons, or for the development, production, maintenance or storage of missiles for such weapons; 2) civil firearms, including spare parts or ammunition for such arms; 3) defense related products, or other material for military use or for law enforcement; 4) any applications that, alone or in combination with other goods, substances or organisms could cause serious harm to persons or goods and that can be used as a means of violence in an armed conflict or any similar violent situation.

The Products sold by Melexis are subject to the terms and conditions as specified in the Terms of Sale, which can be found at <https://www.melexis.com/en/legal/terms-and-conditions>.

This document supersedes and replaces all prior information regarding the Product(s) and/or previous versions of this document.

Melexis NV © - No part of this document may be reproduced without the prior written consent of Melexis. (2018)

ISO/TS 16949 and ISO14001 Certified

19. Disclaimer