



**SF2024D**

**467.751 MHz  
SAW Filter**

- Designed for SDARS Receiver IF Application
- Low Insertion Loss
- 3.8 X 3.8 X 1.2 mm Surface-Mount Case
- Differential Input and Output
- Complies with Directive 2002/95/EC (RoHS)



**Absolute Maximum Ratings**

Rating	Value	Units
Maximum Incident Power in Passband	+10	dBm
Max. DC voltage between any 2 terminals	30	VDC
Storage Temperature Range	-40 to +85	°C
Suitable for lead-free soldering - Max Soldering Profile	260°C for 30 s	

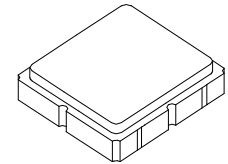

**SM3838-8**

**Electrical Characteristics**

Characteristic	Sym	Notes	Min	Typ	Max	Units
Center Frequency	$f_c$	1	467.704	467.751	467.798	MHz
Insertion Loss	IL	1		12	13	dB
Amplitude Ripple (p-p)		1, 2	fc-6.250 to fc-4.3925 MHz		2.0	dB
			fc-4.3925 to fc-2.535 MHz		2.0	
			fc-2.5350 to fc-0.025 MHz		2.0	
			fc+0.025 to fc+2.535 MHz		2.0	
			fc+2.5350 to fc+4.3925 MHz		2.0	
			fc+4.3925 to fc+6.250 MHz		2.0	
Pass bandwidth of -2.0dB centered at $f_c$				13.0		MHz
Pass bandwidth of -3 dB						
Low Side Attenuation between 455.751 to 457.251 MHz (fc-10.5 MHz)			32			dB
Low Side Attenuation F<455.751 MHz			32			
High Side Attenuation between 476.751 to 479.751 MHz (fc+9.0 MHz)			20			
High Side Attenuation F<479.751 MHz			32			
Temperature Coefficient of frequency					-18	ppm/K
Delay Ripple (p-p)		1, 2, 3	fc-6.250 to fc-4.3925 MHz		100	ns
			fc-4.3925 to fc-2.535 MHz		100	
			fc-2.5350 to fc-0.025 MHz		120	
			fc+0.025 to fc+2.535 MHz		120	
			fc+2.5350 to fc+4.3925 MHz		100	
			fc+4.3925 to fc+6.250 MHz		100	
Source Impedance	ZS			150		$\Omega$
Load Impedance	ZL			150		$\Omega$
Case Style		6	SM3838-8 3.8 x 3.8 mm Nominal Footprint			
Lid Symbolization (YY=year, WW=week, S=shift) See note 4			580 YWWS			



**CAUTION: Electrostatic Sensitive Device. Observe precautions for handling.**

**Notes:**

1. Unless noted otherwise, all specifications apply over the operating temperature range with filter soldered to the specified demonstration board with impedance matching to 50  $\Omega$  and measured with 50  $\Omega$  network analyzer.
2. Unless noted otherwise, all frequency specifications are referenced to the nominal center frequency,  $f_c$ .
3. Rejection is measured as attenuation below the minimum IL point in the passband. Rejection in final user application is dependent on PCB layout and external impedance matching design. See Application Note No. 42 for details.
4. The design, manufacturing process, and specifications of this filter are subject to change.
5. Tape and Reel Standard Per ANSI / EIA 481.
6. US and international patents may apply.
7. RFM, stylized RFM logo, and RF Monolithics, Inc. are registered trademarks of RF Monolithics, Inc.
8. ©Copyright 1999, RF Monolithics Inc.

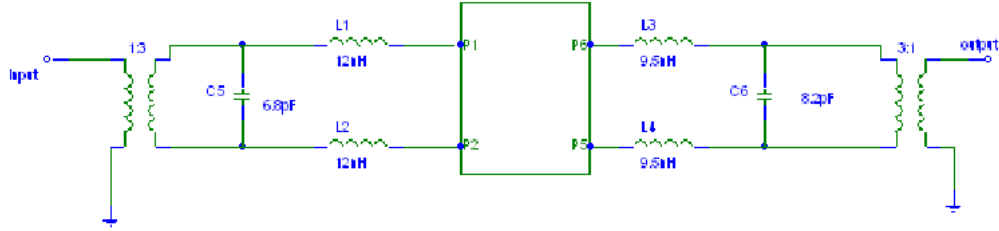

29 Aug 2005 12:18:12

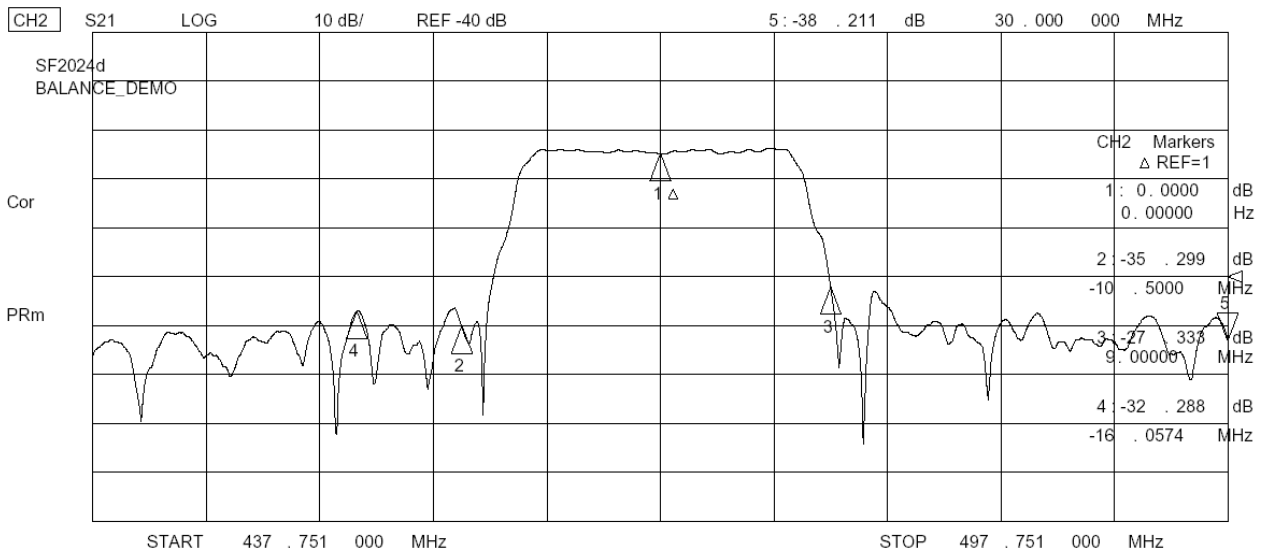
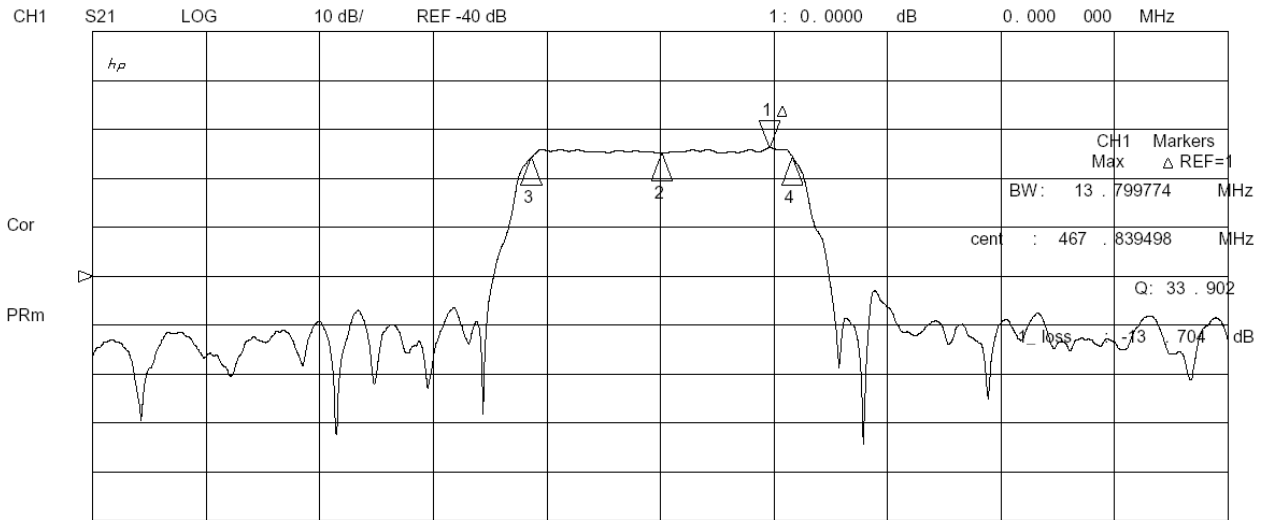

29 Aug 2005 12:21:47

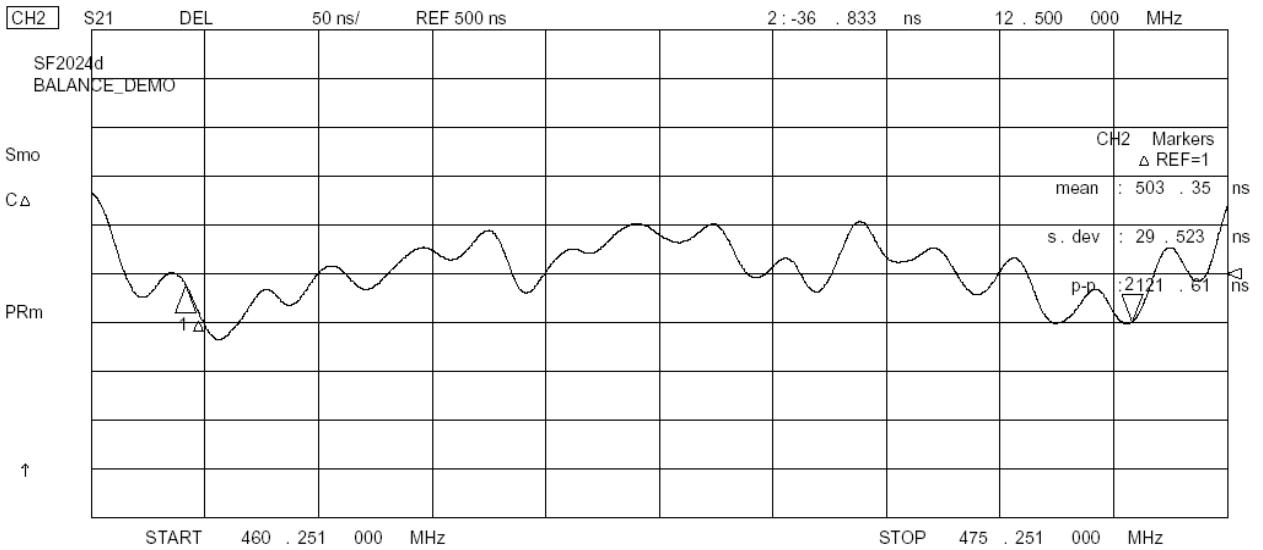
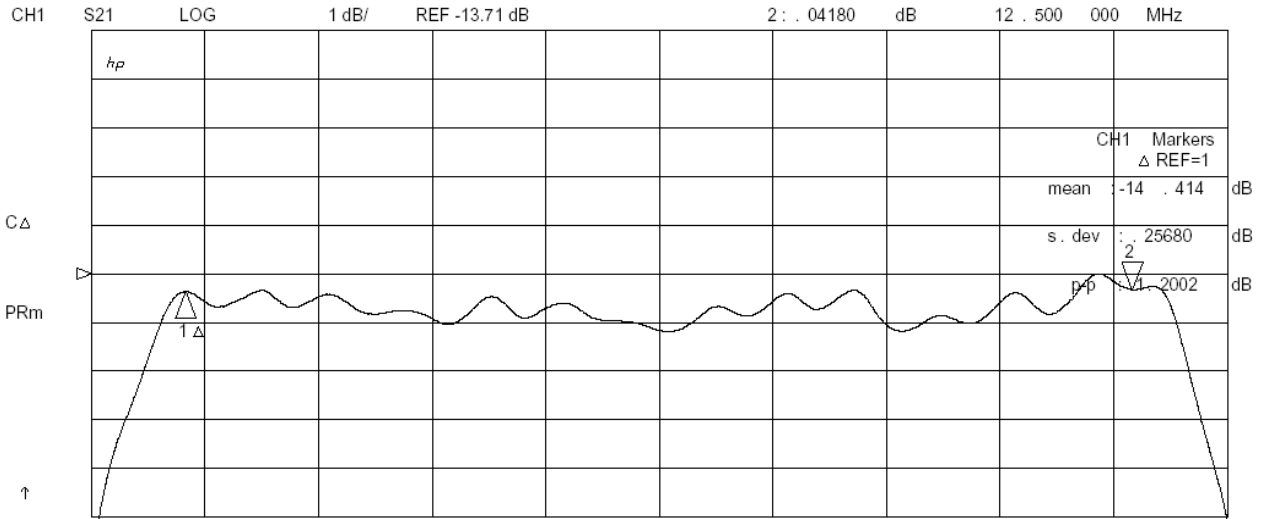

# SM3838-8 Case

## 8-Terminal Ceramic Surface-Mount Case

### 3.8 X 3.8 mm Nominal Footprint

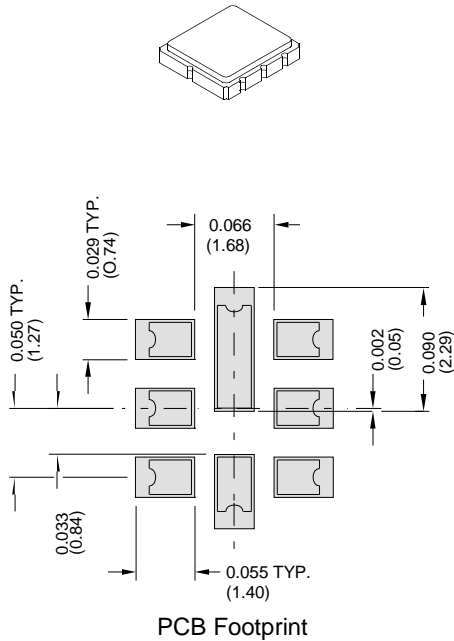

Case Dimensions						
Dimension	mm			Inches		
	Min	Nom	Max	Min	Nom	Max
A	3.6	3.8	4.0	0.142	0.150	0.157
B	3.6	3.8	4.0	0.142	0.150	0.157
C	1.05	1.20	1.35	0.041	0.047	0.053
D	0.95	1.10	1.25	0.037	0.043	0.049
E	0.90	1.00	1.10	0.035	0.040	0.043
F	0.50	0.60	0.70	0.020	0.024	0.028
G	2.39	2.54	2.69	0.090	0.100	0.110
H	1.40	1.75	2.05	0.055	0.069	0.080

Electrical Connections		
	Connection	Terminals
Port 1	Differential Input	1, 2
Port 2	Differential Output	5, 6
	Ground	All Others
<b>Single Ended Operation</b>		<b>Return is Ground</b>
<b>Differential Operation</b>		<b>Return is Hot</b>
Dot Indicates Pin 1		

Materials	
Solder Pad Termination	Au plating 30 - 60 ulnches (76.2-152 uM) over 80-200 ulnches (203-508 uM) Ni.
Lid	Fe-Ni-Co Alloy Electroless Nickel Plate (8-11% Phosphorus) 100-200 ulnches Thick
Body	Al <sub>2</sub> O <sub>3</sub> Ceramic
Pb Free	

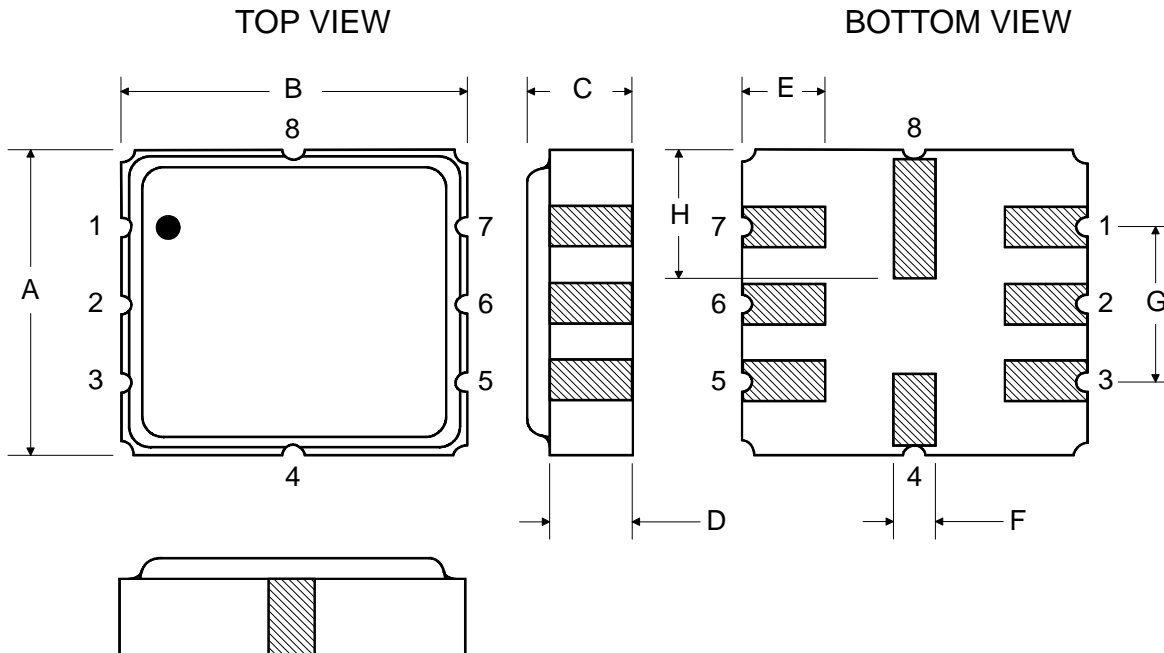

## Tape and Reel Specifications

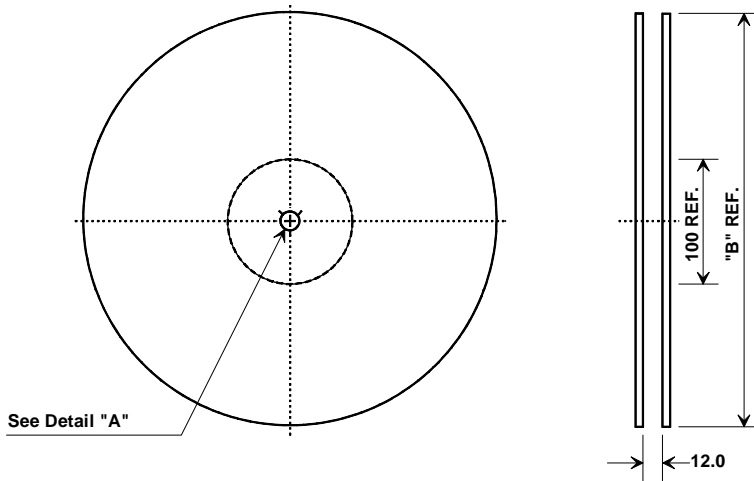

"B" Nominal Size		Quantity Per Reel
Inches	millimeters	
7	178	500
13	330	3000

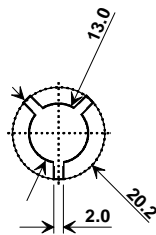

## COMPONENT ORIENTATION and DIMENSIONS

Carrier Tape Dimensions	
Ao	4.25 mm
Bo	4.25 mm
Ko	1.30 mm
Pitch	8.0 mm
W	12.0 mm

