

W1G250 Series

Tubeaxial

280x280x80mm



- DC fans with electronically commutated external rotor motor. Fully integrated commutation electronics.
- Maintenance-free ball bearings.
- Die-cast aluminum housing. Impeller of sheet steel, welded onto rotor and stove-enameled.
- Mounting from either face using four 4.3 mm holes.
- Air exhaust over struts. Rotational direction CCW looking at rotor.
- Connecting leads with terminal strip.
- UL, CSA, VDE approvals on some models, please contact application engineering.

Part Number	Curve	CFM @ 0	VDC	Volt. Range	Power (W)	dBA	Max Amb. Temp C	Bearing Type	Features	Wgt. (lbs)
W1G250-HH37-52	1	1130.1	24	16 to 28	105.0	70	60	Ball	Terminal Block	5.52
W1G250-HH67-52	1	1130.1	48	36 to 57	105.0	70	60	Ball	Terminal Block	5.52

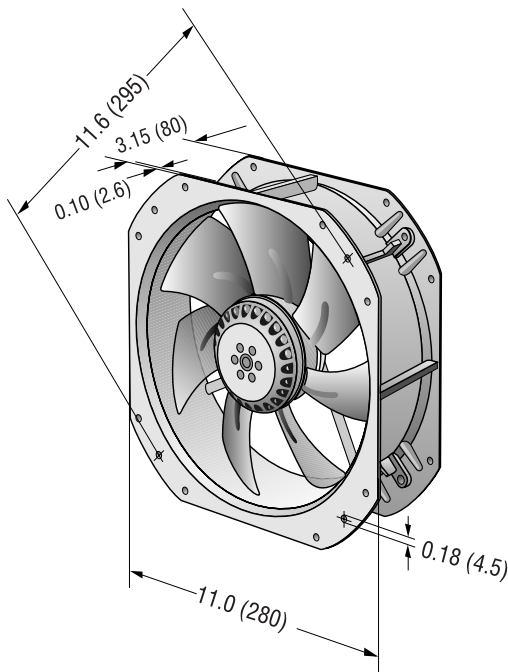

	N [RPM]	P ₁ [W]	η _u [%]	L _{DA} [dBA]
1 ①	2920	129	-	71
1 ②	2800	132	63	72
1 ③	2680	135	60	71
1 ④	2600	139	45	72
1 ①	2750	105	-	70
1 ②	2630	110	63	69
1 ③	2520	111	60	69
1 ④	2440	114	45	70
1 ⑤	2610	73	-	66
1 ⑥	2320	75	63	67
1 ⑦	2230	78	60	67
1 ⑧	2170	80	45	68

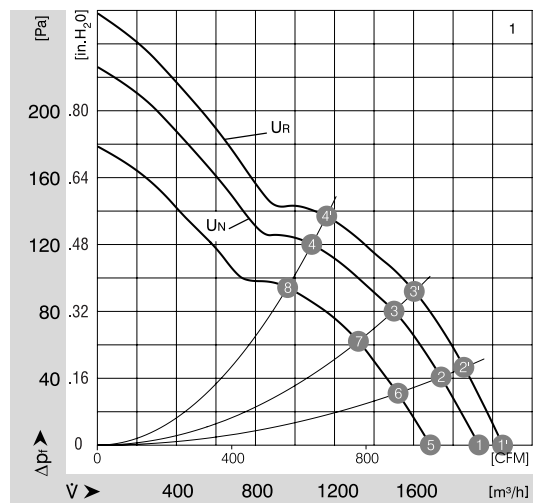

ebmpapst

e-mail: sales@us.ebmpapst.com · TEL: 860-674-1515 · FAX: 860-674-8536

ebm-papst Inc., 100 Hyde Road, Farmington, CT 06034 USA

ebm-papst Inc., 2006 © ebm-papst Inc. reserves the right to change any specifications or data without notice