

SPECIFICATION CONTROL DRAWING

WXA-0059

TITLE WIRE, ELECTRIC, RADIATION-CROSSLINKED, POLYALKENE-INSULATED
TIN-COATED COPPER, LIGHTWEIGHT, GENERAL PURPOSE, 600 VOLT

Date 08-15-01

Revision E

This specification sheet forms a part of the latest issue of Raychem Specification 44.

CONDUCTOR - TIN-COATED COPPER (AWG 22-10)
SILVER-COATED HIGH STRENGTH
COPPER ALLOY (AWG 24 ONLY)

JACKET - RADIATION-CROSSLINKED, MODIFIED ETFE
20 - 24 AWG THICKNESS: .007 ± .001 in.
10 - 18 AWG THICKNESS: .005 ± .001 in.

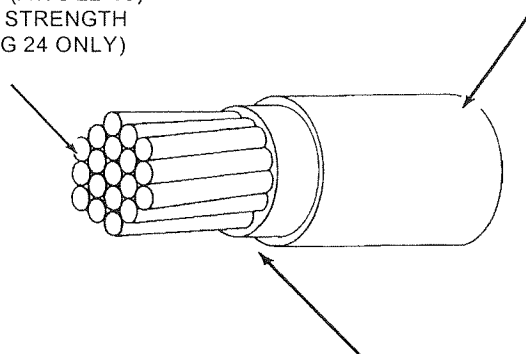

PRIMARY INSULATION - RADIATION-CROSSLINKED,
EXTRUDED POLYALKENE
COLOR - LIGHT ORANGE

TABLE I. CONSTRUCTION DETAILS

PART NUMBER	WIRE SIZE (AWG)	CONDUCTOR STRANDING (number x AWG)	DIAMETER OF STRANDED CONDUCTOR (in.)		FINISHED WIRE		
			MINIMUM	MAXIMUM	MAXIMUM RESISTANCE AT 20°C (ohms/1000ft)	DIAMETER (in.)	MAXIMUM WEIGHT (lb/1000 ft)
WXA-0059-24-*	24	19 x 36	.023	.025	28.4	.045 ± .002	2.3
WXA-0059-22-*	22	19 x 34	.029	.032	16.2	.052 ± .002	3.3
WXA-0059-20-*	20	19 x 32	.037	.041	9.88	.060 ± .002	4.9
WXA-0059-18-*	18	19 x 30	.046	.051	6.23	.071 ± .002	7.3
WXA-0059-16-*	16	19 x 29	.052	.058	4.81	.079 ± .002	9.2
WXA-0059-14-*	14	19 x 27	.065	.073	3.06	.093 ± .002	13.6
WXA-0059-12-*	12	37 x 28	.084	.090	2.02	.114 ± .003	20.7
WXA-0059-10-*	10	37 x 26	.106	.114	1.26	.139 ± .003	32.5

TABLE II. PERFORMANCE DETAILS

PART NUMBER	BEND TESTING			
	MANDREL DIAMETER (inch) (± 3%)		WEIGHT (lb) (± 3%)	
	IMMERSION, LIFE CYCLE AND ACCELERATED AGING	COLD BEND	IMMERSION, LIFE CYCLE AND ACCELERATED AGING	COLD BEND
WXA-0059-24-*	.500	1.00	.500	3.00
WXA-0059-22-*	.750	1.00	1.50	3.00
WXA-0059-20-*	.750	1.00	2.00	4.00
WXA-0059-18-*	1.00	1.25	2.00	4.00
WXA-0059-16-*	1.00	1.25	2.00	5.00
WXA-0059-14-*	1.25	2.00	2.00	5.00
WXA-0059-12-*	2.00	2.00	2.00	5.00
WXA-0059-10-*	3.00	3.00	2.00	5.00

NOTE: Nominal values are for information only.
Nominal values are not requirements.

COLORS AND COLOR CODE DESIGNATORS SHALL BE IN ACCORDANCE WITH MIL-STD-681.

DIMENSIONS ARE IN INCHES, AND UNLESS OTHERWISE DESIGNATED ARE NOMINAL.

WIRE RATINGS AND ADDITIONAL REQUIREMENTS

TEMPERATURE RATING: 150°C

Maximum continuous conductor temperature

VOLTAGE RATING: 600 volts (rms)

ACCELERATED AGING: 300 ± 3°C for 7 hours

BLOCKING: 200 ± 3°C for 24 hours, per Raychem Spec 55A

COLOR: White preferred

FLAMMABILITY: 30 seconds (maximum); 3 inch (maximum);
no flaming of facial tissue

HUMIDITY RESISTANCE: After humidity exposure, wire shall
meet the requirements for initial Insulation Resistance

IDENTIFICATION AND COLOR STRIPING DURABILITY: 125 cycles
(250 strokes) (minimum), 500 g weight

IMMERSION: Diameter increase 5% (maximum);
no cracking, no dielectric breakdown

INSULATION RESISTANCE: 5000 megohms for 1000 ft. (minimum) AWG 24-14,
3000 megohms for 1000 ft. (minimum) AWG 12-10

INSULATION ELONGATION AND TENSILE STRENGTH:
(Primary insulation and jacket pulled together at 2 inches/minute)
Tensile Strength, 3000 lbf/in² (minimum)

Elongation, 75% (minimum)

INSULATION FLAWS:

Primary Insulation,

Spark Test, 1.5 kV, 60 Hz (rms), 100% test

Impulse Dielectric Test, 6.0 kV (peak), 100% test

Finished Wire,

Impulse Dielectric Test, 8.0 kV (peak), 100% test

LIFE CYCLE: 200 ± 2°C for 168 hours

LOW TEMPERATURE-COLD BEND: -65 ± 2°C for 4 hours

SHRINKAGE: 230 ± 2°C, 0.125 inch (maximum) in 12 inches

SMOKE TEST: 200 ± 5°C

SURFACE RESISTANCE: 500 megohms-inch (minimum), both readings

THERMAL SHOCK RESISTANCE: 150 ± 2°C, 0.060 inch (maximum)

VOLTAGE WITHSTAND TEST (POST ENVIRONMENTAL):

2500 volts (rms), 60 Hz, 5 minutes

PART NUMBER:

The "*" in the part numbers on page 1 shall be replaced by color code designators.

Example: AWG 20, white: WXA-0059-20-9