

LTC6362 Driving 18-Bit SAR ADC

DESCRIPTION

The LTC[®]6362 is a low power, low noise differential op amp with rail-to-rail input and output swing that has been optimized to drive low power SAR ADCs. The amplifier may be configured to buffer a fully differential input signal or convert a single-ended input signal to a differential output signal.

The LTC2380/LTC2379/LTC2378/LTC2377/LTC2376 are low power, low noise ADCs with serial outputs that can operate from a single 2.5V supply. The DC1805A demonstrates the DC and AC performance of the LTC6362 driving the LTC2379-18 when used in conjunction with the DC590B QuikEval[™] and DC718 fast DACs data collection boards.

Use the DC590B to demonstrate DC performance such as peak-to-peak noise and DC linearity. Use the DC718 if precise sampling rates are required or to demonstrate AC performance such as SNR, THD, SINAD and SFDR. The DC1805A is intended to demonstrate recommended grounding, component placement and selection, routing and bypassing for LTC6362 and the ADC.

Design files for this circuit board are available at <http://www.linear.com/demo>

LT, LTC, LTM, Linear Technology and the Linear logo are registered trademarks and QuikEval and PScope are trademarks of Linear Technology Corporation. All other trademarks are the property of their respective owners.

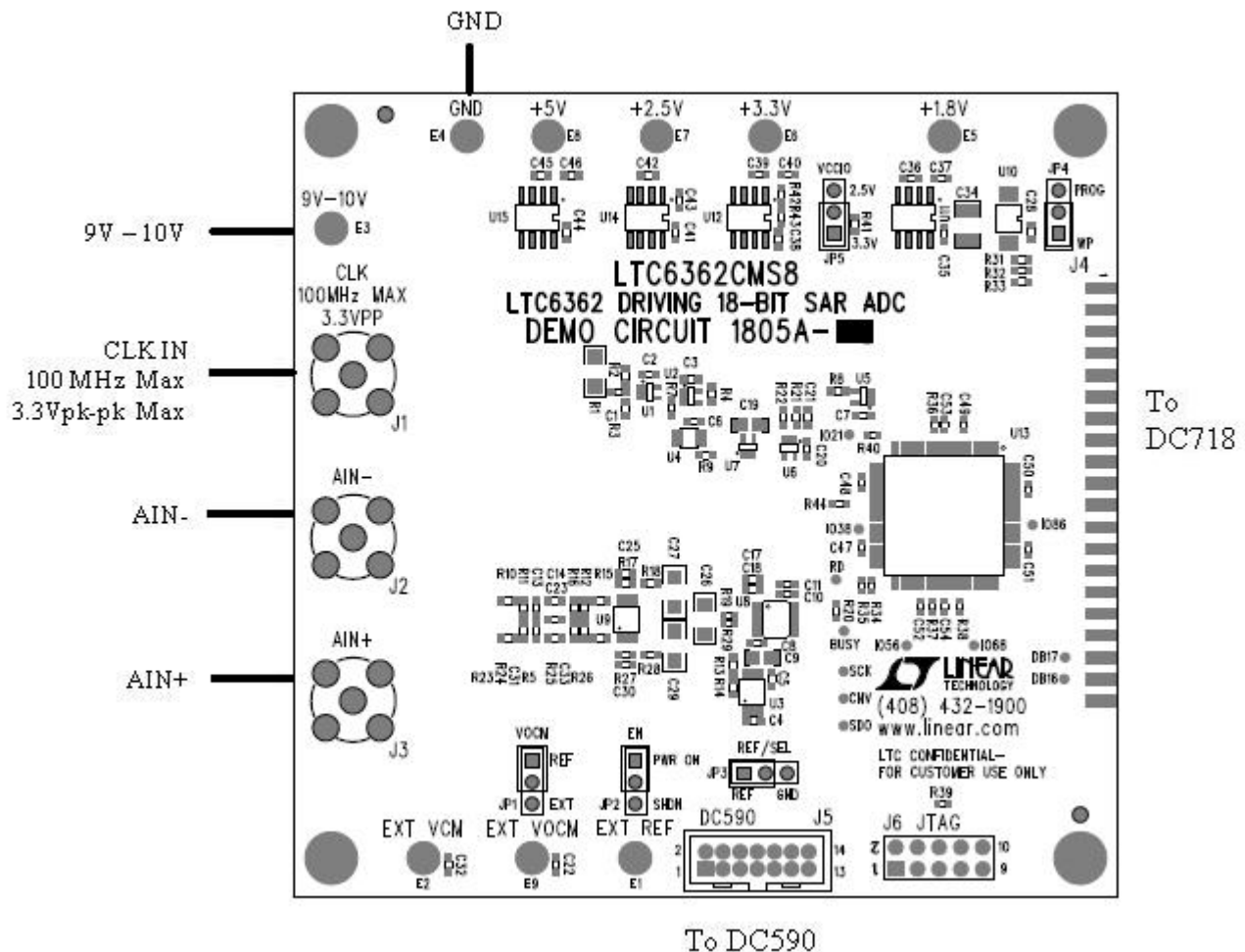

Figure 1. DC1805A Connection Diagram

DEMO MANUAL DC1805A

DESCRIPTION

Table 1. DC1805A Assembly Options

ASSEMBLY VERSION	PART NUMBER	MAX CONVERSION RATE	NUMBER OF BITS	MAX CLK IN FREQUENCY
DC1805A-A	LTC2380CMS-16	2Msps	16	100MHz
DC1805A-B	LTC2378CMS-16	1Msps	16	50MHz
DC1805A-C	LTC2377CMS-16	500ksps	16	25MHz
DC1805A-D	LTC2376CMS-16	250ksps	16	12.5MHz
DC1805A-E	LTC2379CMS-18	1.6Msps	18	99.2MHz
DC1805A-F	LTC2378CMS-18	1Msps	18	62MHz
DC1805A-G	LTC2377CMS-18	500ksps	18	31MHz
DC1805A-H	LTC2376CMS-18	250ksps	18	15.5MHz

QUICK START PROCEDURE

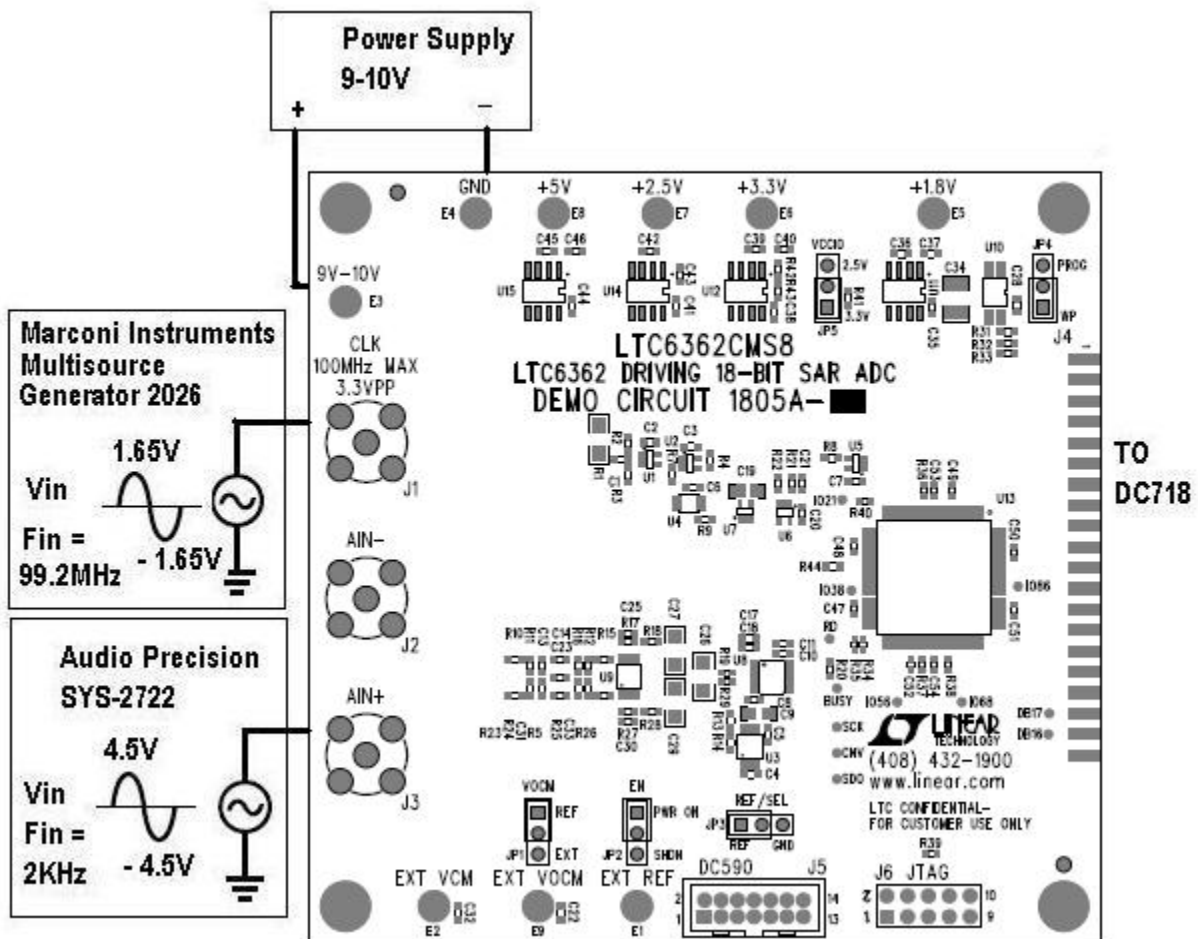

Figure 2. DC1805A Test Diagram

QUICK START PROCEDURE

This board is tested by measuring the distortion at the differential output given a -1dBFS , 2kHz single-ended input as shown in Figure 2.

For SINAD, THD or SNR testing a low noise, low distortion generator such as Audio Precision SYS-2722, B&K Type 1051 or Stanford Research DS360 should be used. A low jitter RF oscillator such as the Marconi Instruments, Multisource Generator 2026 should be used as the clock source.

To test the boards please follow the steps below:

- 1) Make sure that all the jumpers are set as shown in Figure 2 (DC1805A Test Diagram).
- 2) Power up the board by applying 9VDC.

- 3) Apply the clock signal to connector J1. Clock frequency 99.2MHz (to achieve 1.6Msps conversion rate, please refer to the Clock Source section for more detailed information), V_{IN} 3.3V_{P-P}.

- 4) A single pole lowpass filter should be used for best SNR measurement data. One option is to create an on-board RC low pass filter by populating R5 with 200 Ω and C33 with 0.22 μF . It is very important to use a very low distortion capacitor. In order to balance both inputs of the LTC6362 populate R12 with a 200 Ω resistor in parallel with a 0.22 μF capacitor.

- 5) Apply a 2kHz, -1dBFS signal to connector J3.

The performance that results from these connections are displayed in Figure 4.

DC718 QUICK START PROCEDURE

Check to make sure that all switches and jumpers are set as shown in the connection diagram of Figure 1. The default connections configure the ADC to use the onboard reference and regulators to generate the required common mode voltages. The analog input is DC coupled. Connect the DC1805A to a DC718 USB high speed data collection board using connector J4. Then, connect the DC718 to a host PC with a standard USB A/B cable. Apply 9V to the indicated terminals. Then apply a low jitter signal source to J3. Connect a low jitter 100MHz 3.3V_{P-P} sine wave or square wave to connector J1. Note that J1 has a 50 Ω termination resistor to ground.

Run the QuikEval-II software (Pscope.exe version K72 or later) supplied with the DC718 or download it from www.linear.com.

Complete software documentation is available from the Help menu. Updates can be downloaded from the Tools menu. Check for updates periodically as new features may be added.

The PScope™ software should recognize the DC1805A and configure itself automatically.

Click the Collect button (see Figure 4) to begin acquiring data. The Collect button then changes to Pause, which can be clicked to stop data acquisition.

DC590B SETUP

IMPORTANT! To avoid damage to the DC1805A, make sure that VCCIO (JP5) is set to 3.3V before connecting the DC590B to the DC1805A.

Connect the DC590B to a host PC with a standard USB A/B cable. Connect the DC1805A to a DC590B USB serial

controller using the supplied 14-conductor ribbon cable. Run the evaluation software supplied with the DC590B or download it from www.linear.com.

The correct control panel will be loaded automatically. Click the Collect button to begin reading the ADC.

DC1805A SETUP

DC Power

The DC1805A requires 9VDC and draws less than 70mA. Most of the supply current is consumed by the CPLD, regulators and discrete logic on the board. The 9VDC input voltage powers the LTC6362 and the ADC through LT®1763 regulators which provide protection against accidental reverse bias. Additional regulators provide power for the CPLD. See Figure 1 for connection details.

Clock Source

You must provide a low jitter 3.3V_{P-P} maximum sine or square wave to J1. The clock input is AC-coupled so the DC level of the clock signal is not important. A generator like the Marconi Instruments, Multisource Generator 2026, HP8644 or the DC1216A-A is recommended. Even a good generator can start to produce noticeable jitter at low frequencies. Therefore it is recommended for lower sample rates to divide down a higher frequency clock to the desired sample rate. The ratio of clock frequency to conversion rate is 62:1 for 18-bit parts and 50:1 for 16-bit parts. If the clock input is to be driven with logic, it is recommended that the 50Ω terminator (R1) be removed. Slow rising edges may compromise the SNR of the converter in the presence of high amplitude higher frequency input signals.

Reference

The default reference is a LTC6655 5V reference. An external reference can be used by removing (U3) and populating (R6) with 0 resistor. If an external reference is used it must settle quickly in the presence of glitches on the REF pin.

Analog Input

LTC6362 drives the analog input of the LTC2379-18 on the DC1805A as shown in Figure 3. This circuit converts a single-ended input signal to a differential output signal applied at the ADC inputs. Please refer to the LTC6362 data sheet for various configurations of the LTC6362 interface to the SAR ADC.

AC-coupling the input may degrade the distortion performance of the ADC due to nonlinearity of the coupling capacitor.

Component Selection

When driving a low noise, low distortion ADC such as the LTC2379-18 with the LTC6362, component selection is important so as to not degrade performance. Resistors should have low values to minimize noise and distortion. Metal film resistors are recommended to reduce distortion caused by self heating. To further reduce distortion, NPO or silver mica capacitors should be used because of their low voltage coefficients.

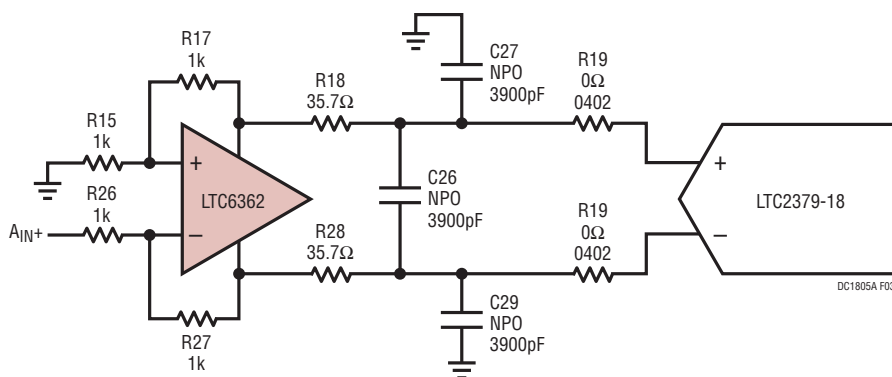

Figure 3. LTC6362 Ground Referenced Single-Ended to Differential Converter

DC1805A SETUP

Jumpers

JP1 – Sets the DC bias for V_{OCM} of the LTC6362 to be internally biased or externally driven. The voltage on this pin sets the output common mode voltage level. $V_{REF}/2$ is the default setting.

JP2 – Toggles the LTC6362 On and Off. Part On (5V) is the default setting.

JP3 – In the REF position the Digital Gain Compression is off and the analog input range at ADC inputs is 0V to V_{REF} . In the GND position Digital Gain Compression is turned on and the analog input range at ADC inputs is $0.1V_{REF}$ to $0.9V_{REF}$.

JP4 – Ties the WP pin to V_{CC} or GND. WP is the hardware write-protect pin. If tied to V_{CC} , hardware write protection is enabled. If WP is tied to GND, the hardware write-protection is disabled.

JP5 – VCCIO sets the output levels at J3 to either 3.3V or 2.5V. Use 3.3V to interface to the DC718 which is the default setting.

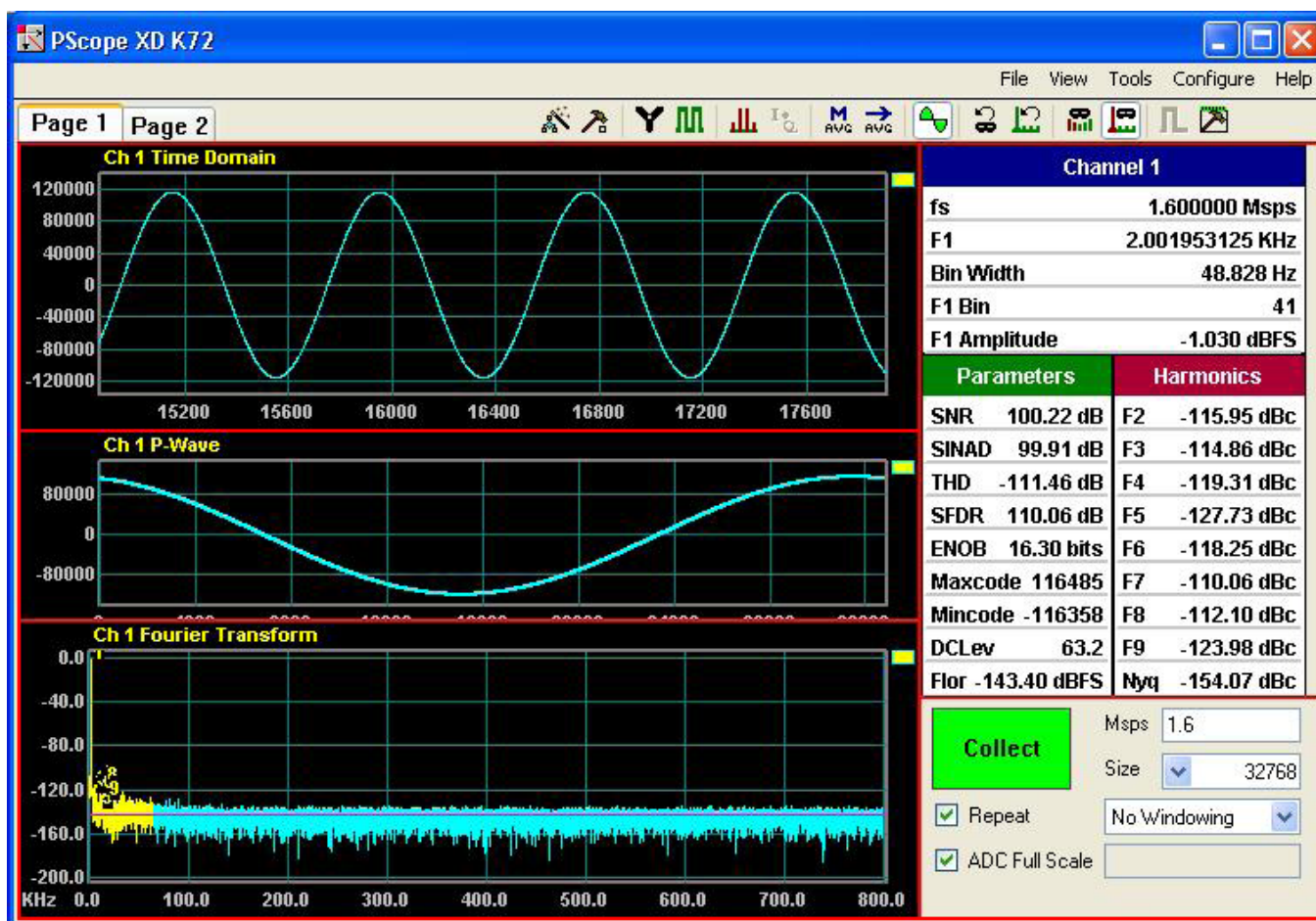

Figure 4. PScope Screenshot

DEMO MANUAL DC1805A

PARTS LIST

ITEM	QTY	REFERENCE	PART DESCRIPTION	MANUFACTURER/PART NUMBER
1	14	C1, C2, C3, C4, C6, C7, C8, C10, C15, C16, C18, C20, C21, C28	Capacitor, X7R, 0.1µF, 25V, 10%, 0603	AVX, 06033C104KAT2A
2	5	C22, C35, C38, C41, C44	Capacitor, X7R, 1µF, 16V, 10%, 0603	AVX, 0603YC105KAT2A
3	1	C9	Capacitor, X5R, 47µF 6.3V, 20%, 0805	Taiyo Yuden, JMK212BJ476MG-T
4	7	C5, C11, C17, C37, C40, C43, C46	Capacitor, X5R, 10µF 6.3V, 20%, 0603	TDK, C1608X5R0J106MT
5	1	C12	Capacitor, X7R, 4.7µF 10V, 10%, 0805	AVX, 0805ZC475KAT2A
6	1	C19	Capacitor, X7R, 0.1µF, 25V, 5%, 0805	AVX, 08053C104JAT2A
7	1	C24	Capacitor, X7R, 0.01µF, 16V,10%, 0402	AVX, 0402YC103KAT2A
8	0	C13, C14, C23, C25, C30, C31, C32, C33	Capacitor, 0603	OPT
9	3	C26, C27, C29	Capacitor, Ceramic 3900pF, 100V NPO,1206	AVX, 12061A392JAT2A
10	1	C34	Capacitor, X5R, 22µF 16V, 20%, 1210	Taiyo Yuden, EMK325BJ226MM-T
11	4	C36, C39, C42, C45	Capacitor, X7R, 0.01µF, 16V,10%,0603	AVX, 0603YC103KAT
12	8	C47, C48, C49, C50, C51, C52, C53, C54	Capacitor, X7R, 0.1µF, 16V,10%, 0402	TDK, C1005X7R1C104KT
13	5	E1, E2, E3, E4, E5, E6, E7, E8, E9	TR Turret, 0.094"	Mill-Max, 2501-2-00-80-00-00-07-0
14	3	J1, J2, J3	Connector, BNC-5PINS	Connex, 112404
15	1	J4	Connector, 40 Pins SMT, CON-EDGE40-100	Samtec, TSW-120-07-L-D
16	1	J5	Header, 2x7, 0.079"	Molex, 87831-1420
17	1	J6	Header, 2x5, 0.100", HD2X5-100	Samtec, TSW-105-07-L-D
18	5	JP1-JP5	Jumper, 1x3, 0.100", HD1X3-100	Samtec, TSW-103-07-L-S
19	1	R1	Resistor, Chip 49.9, 1%, 1206	NIC, NRC12F49R9TRF
20	11	R2, R3, R13, R14, R15, R17, R20, R21, R26, R27, R30	Resistor, Chip 1k, 1%, 0603	NIC, NRC06F1001TRF
21	5	R4, R7, R8, R9, R44	Resistor, Chip 33, 1%, 0603	NIC, NRC06F33R0TRF
22	4	R5, R10, R12, R23	Resistor, Chip 0, 1%, 0603	NIC, NRC06F0000TRF
23	0	R6, R11, R16, R24, R25	Resistor, 0603	OPT
24	2	R18, R28	Resistor, Chip 35.7, 1%, 0603	Vishay, CRCW060335R7FKEA
25	2	R19, R29	Resistor, Chip 0, 1/16W, 1%, 0402	NIC, C04F0000TRF
26	1	R22	Resistor, Chip 2k, 1%, 0603	NIC, NRC06F2001TRF
27	3	R31, R32, R33	Resistor, Chip 4.99k, 1%, 0603	NIC, NRC06F4991TRF
28	1	R34	Resistor, Chip 10k, 1%, 0402	NIC, NRC04F1002TRF
29	4	R36, R37, R38, R40	Resistor, Chip 1k, 1%, 0402	NIC, NRC04F1001TRF
30	1	R39	Resistor, Chip 10k, 1%, 0603	NIC, NRC06F1002TRF
31	1	R41	Resistor, Chip 2.80k, 1%, 0603	NIC, NRC06F2801TRF
32	1	R42	Resistor, Chip 1.69k, 1%, 0603	NIC, NRC06F1691TRF
33	1	R43	Resistor, Chip 1.54k, 1%, 0603	NIC, NRC06F1541TRF
34	2	U1, U6	IC., Tinylogic UHS Inverter, SC70-5	Fairchild, NC7SZ04P5X
35	2	U2, U5	IC., Tinylogic ULP-A Unbuffered Inverter, SC70-5	Fairchild, NC7SVU04P5X
36	1	U3	IC., LTC6655CHMS8-5, MS8	Linear Technology, LTC6655CHMS8-5#PBF
37	1	U4	IC., Single D Flip Flop, US8	ON Semiconductor, NL17SZ74 (USG)
38	1	U7	IC., Single SPST Bus Switch, SC70-5	Fairchild, NC7SZ66P5X
39	1	U9	IC., LTC6362CMS8, MS8	Linear Technology, LTC6362CMS8
40	1	U10	IC., Serial EEPROM, TSSOP	Microchip, 24LC024-I/ST

PARTS LIST

ITEM	QTY	REFERENCE	PART DESCRIPTION	MANUFACTURER/PART NUMBER
41	1	U11	IC., LT1763CS8-1.8, S08	Linear Technology, LT1763CS8-1.8#PBF
42	1	U12	IC., LT1763CS8, S08	Linear Technology, LT1763CS8#PBF
43	1	U13	IC., MAX II Family, TQFP100	Altera, EPM240GT100C5N
44	1	U14	IC., LT1763CS8-2.5, S08	Linear Technology, LT1763CS8-2.5#PBF
45	1	U15	IC., LT1763CS8-5, S08	Linear Technology, LT1763CS8-5#PBF
46	4	MH1-MH4	Stand-Off, Nylon (Snap On), 0.375" Tall	Keystone, 8832 (Snap On)
47	5	Shunts as Shown on Assembly Drawing (JP1-JP5)	Shunt, .100" Center	Samtec, SNT-100-BK-G
48	2	Stencil for Top and Bottom		Stencil #DC1805A-2

DC1805A-A

1	1	DC1805A-A	General BOM	
2	1	U8	IC., LTC2380CMS-16, MS16	Linear Technology, LTC2380CMS-16
3	0	R35 (OPT)	Resistor, Chip 300Ω, 1%, 0402	OPT

DC1805A-B

1	1	DC1805A-B	General BOM	
2	1	U8	IC., LTC2378CMS-16, MS16	Linear Technology, LTC2378CMS-16
3	0	R35 (OPT)	Resistor, Chip 300Ω, 1%, 0402	OPT

DC1805A-C

1	1	DC1805A-C	General BOM	
2	1	U8	IC., LTC2377CMS-16, MS16	Linear Technology, LTC2377CMS-16
3	0	R35 (OPT)	Resistor, Chip 300Ω, 1%, 0402	OPT

DC1805A-D

1	1	DC1805A-D	General BOM	
2	1	U8	IC., LTC2376CMS-16, MS16	Linear Technology, LTC2376CMS-16
3	0	R35 (OPT)	Resistor, Chip 300Ω, 1%, 0402	OPT

DC1805A-E

1	1	DC1805A-E	General BOM	
2	1	U8	IC., LTC2379CMS-18, MS16	Linear Technology, LTC2379CMS-18
3	1	R35	Resistor, Chip 300Ω, 1%, 0402	NIC, NRC04F3000TRF

DC1805A-F

1	1	DC1805A-F	General BOM	
2	1	U8	IC., LTC2378CMS-18, MS16	Linear Technology, LTC2378CMS-18
3	1	R35	Resistor, Chip 300Ω, 1%, 0402	NIC, NRC04F3000TRF

DC1805A-G

1	1	DC1805A-G	General BOM	
2	1	U8	IC., LTC2377CMS-18, MS16	Linear Technology, LTC2377CMS-18
3	1	R35	Resistor, Chip 300Ω, 1%, 0402	NIC, NRC04F3000TRF

DC1805A-H

1	1	DC1805A-H	General BOM	
2	1	U8	IC., LTC2376CMS-18, MS16	Linear Technology, LTC2376CMS-18
3	1	R35	Resistor, Chip 300Ω, 1%, 0402	NIC, NRC04F3000TRF

DEMO MANUAL DC1805A

SCHEMATIC DIAGRAM

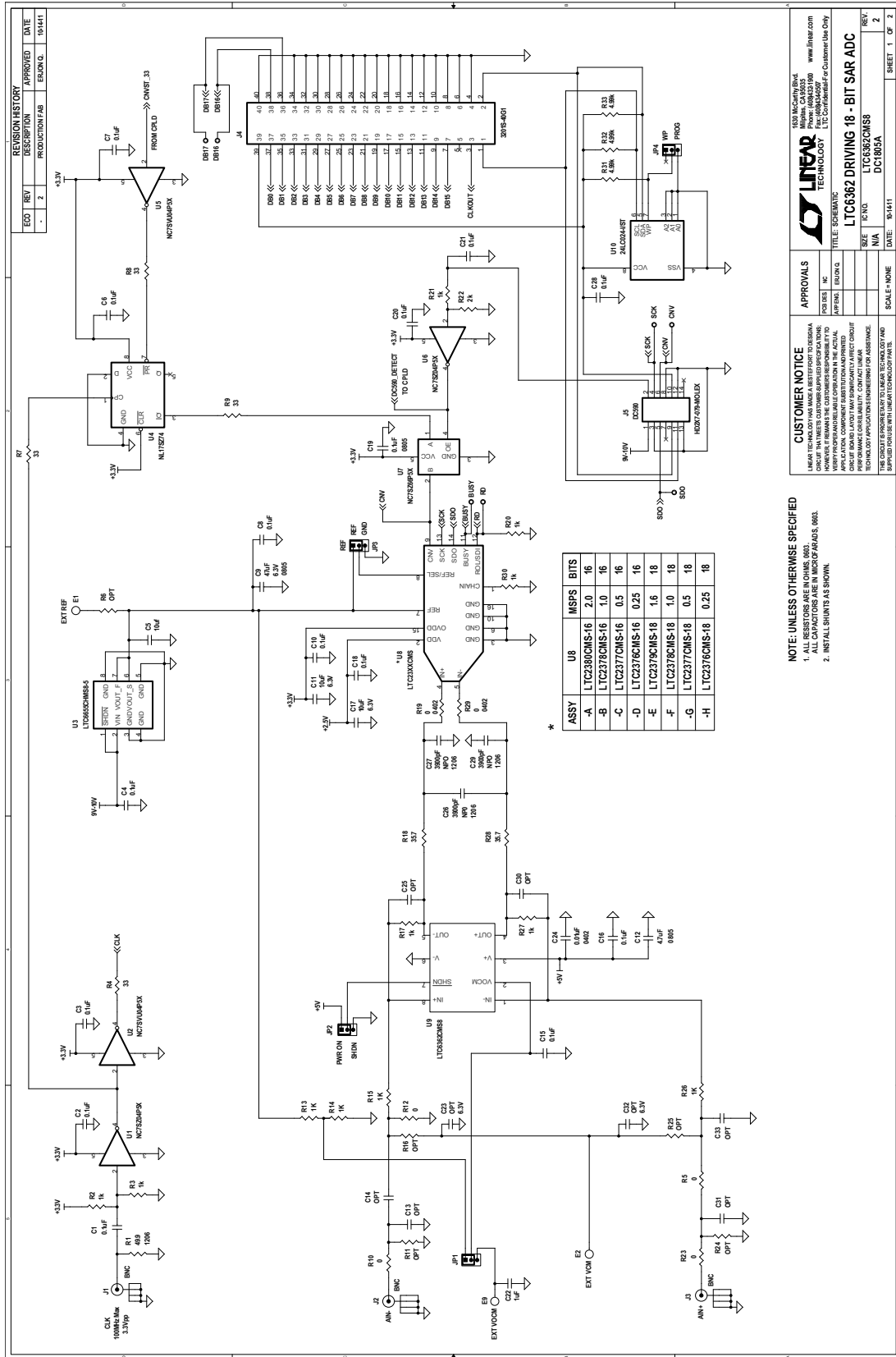

1635 DECAWAY BLVD
FORT LEE, NJ 07024
www.linear.com

LINEAR TECHNOLOGY

FILE: SCHEMATIC
LTC6362 DRIVING 18-BIT SAR ADC

DATE: 01/11

SHEET 1 OF 2

THIS DOCUMENT IS UNCLASSIFIED AND AVAILABLE FOR REUSE IN ANY MANNER WITHOUT PERMISSION FROM LINEAR TECHNOLOGY INC.

dc1805af

SCHEMATIC DIAGRAM

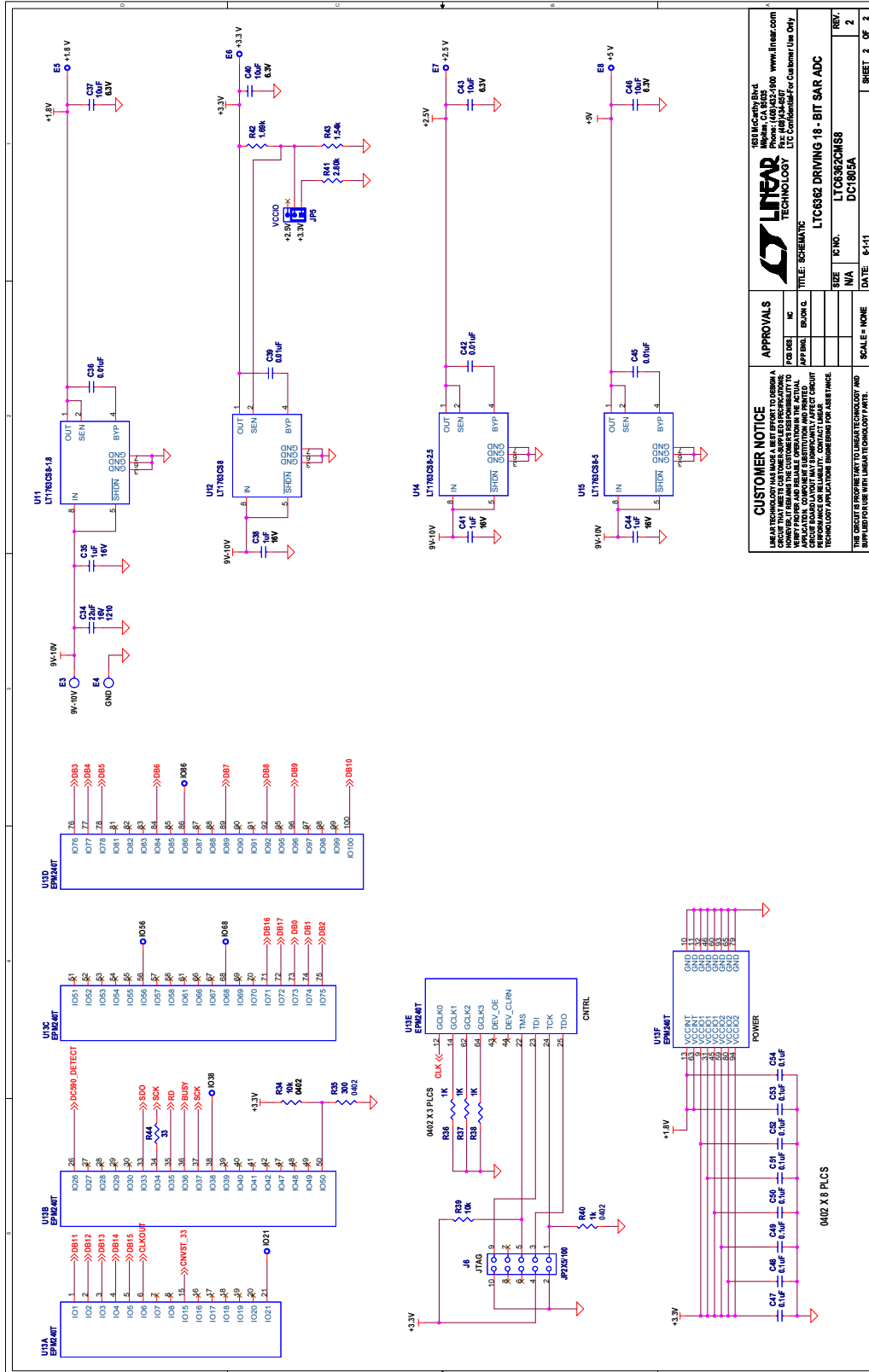

CUSTOMER NOTICE		APPROVALS	
<p>THIS ASSEMBLY IS A DEMO BOARD. IT IS NOT INTENDED FOR PRODUCTION USE. THE CIRCUITRY IS SUBJECT TO CHANGE WITHOUT NOTICE. THE BOARD IS PROVIDED AS-IS AND IS NOT WARRANTED. THE USER ASSUMES ALL LIABILITY FOR ANY DAMAGE OR INJURY RESULTING FROM THE USE OF THIS BOARD.</p>		<p>DESIGNED BY: []</p> <p>DESIGNED BY: []</p> <p>DESIGNED BY: []</p>	<p>DATE: 6/11/11</p> <p>SCALE: NONE</p>
<p>FOR INFORMATION ONLY: THIS BOARD IS NOT A PRODUCT OF LINEAR TECHNOLOGY. IT IS A DEMO BOARD AND IS NOT WARRANTED.</p>		<p>SIZE: N/A</p> <p>DATE: 6/11/11</p>	
<p>LINEAR TECHNOLOGY CORPORATION 90 LINCOLN STREET MILFORD, MA 01860 TEL: 978-683-8000 WWW.LINEAR.COM</p>		<p>REV. 2 OF 2</p>	

DEMO MANUAL DC1805A

DEMONSTRATION BOARD IMPORTANT NOTICE

Linear Technology Corporation (LTC) provides the enclosed product(s) under the following **AS IS** conditions:

This demonstration board (DEMO BOARD) kit being sold or provided by Linear Technology is intended for use for **ENGINEERING DEVELOPMENT OR EVALUATION PURPOSES ONLY** and is not provided by LTC for commercial use. As such, the DEMO BOARD herein may not be complete in terms of required design-, marketing-, and/or manufacturing-related protective considerations, including but not limited to product safety measures typically found in finished commercial goods. As a prototype, this product does not fall within the scope of the European Union directive on electromagnetic compatibility and therefore may or may not meet the technical requirements of the directive, or other regulations.

If this evaluation kit does not meet the specifications recited in the DEMO BOARD manual the kit may be returned within 30 days from the date of delivery for a full refund. **THE FOREGOING WARRANTY IS THE EXCLUSIVE WARRANTY MADE BY THE SELLER TO BUYER AND IS IN LIEU OF ALL OTHER WARRANTIES, EXPRESSED, IMPLIED, OR STATUTORY, INCLUDING ANY WARRANTY OF MERCHANTABILITY OR FITNESS FOR ANY PARTICULAR PURPOSE. EXCEPT TO THE EXTENT OF THIS INDEMNITY, NEITHER PARTY SHALL BE LIABLE TO THE OTHER FOR ANY INDIRECT, SPECIAL, INCIDENTAL, OR CONSEQUENTIAL DAMAGES.**

The user assumes all responsibility and liability for proper and safe handling of the goods. Further, the user releases LTC from all claims arising from the handling or use of the goods. Due to the open construction of the product, it is the user's responsibility to take any and all appropriate precautions with regard to electrostatic discharge. Also be aware that the products herein may not be regulatory compliant or agency certified (FCC, UL, CE, etc.).

No License is granted under any patent right or other intellectual property whatsoever. **LTC assumes no liability for applications assistance, customer product design, software performance, or infringement of patents or any other intellectual property rights of any kind.**

LTC currently services a variety of customers for products around the world, and therefore this transaction **is not exclusive**.

Please read the DEMO BOARD manual prior to handling the product. Persons handling this product must have electronics training and observe good laboratory practice standards. **Common sense is encouraged.**

This notice contains important safety information about temperatures and voltages. For further safety concerns, please contact a LTC application engineer.

Mailing Address:

Linear Technology
1630 McCarthy Blvd.
Milpitas, CA 95035

Copyright © 2004, Linear Technology Corporation