

PART NUMBER	LPA-C011301S-X	REV.	C
DATE	E.C.N. NUMBER AND REVISION COMMENTS		REV.
11.04.02	E.C.N. #10924.		A
02.08.12	E.C.N. #10BRDR.		B
05.12.16	ECN-Lumex201600008		C

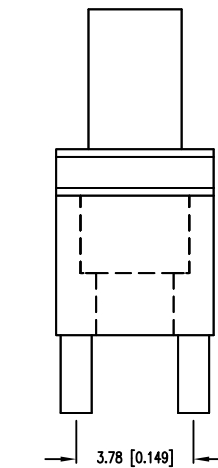

DIM 'L'	SUFFIX: -X
2mm	-2
4mm	-4
5.4mm	-5.4
6mm	-6
7.5mm	-7.5
8.5mm	-8.5
10mm	-10
13mm	-13
15mm	-15
16.5mm	-16.5
20mm	-20
23mm	-23
25mm	-25
30mm	-30
40mm	-40
50mm	-50
100mm	-100
CUSTOM	YOUR LENGTH
*37.9mm	-37.9

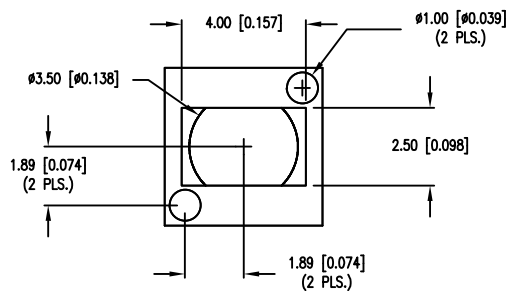
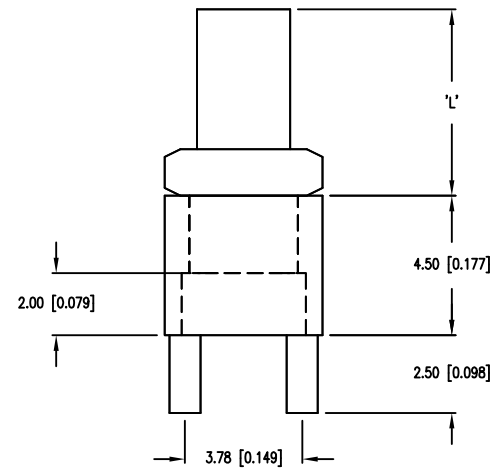
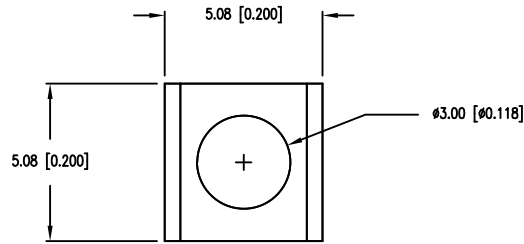
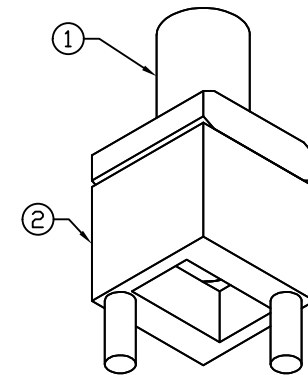
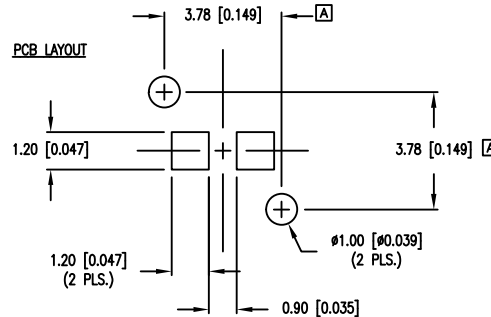

NOTES:

1. MATERIAL: CLEAR POLYCARBONATE UL94V-0. (LIGHT PIPE)
2. MATERIAL: BLACK NORYL, UL94V-0. (HOLDER)
3. TEMP. RANGE: -60°C TO +125°C.
4. RECOMMENDED LED: SML-LX0805xx SERIES.
5. FOR LPA-C011301S-37.9, please check SPEC of LPA-C011301S037.9

*UNLESS OTHERWISE SPECIFIED TOLERANCES PER DECIMAL PRECISION ARE: X=±1 (±0.039), XX=±0.5 (±0.020), XXX=±0.25 (±0.010), XXXX=±0.127 (±0.005). LEAD SIZE=±0.05 (±0.002), LEAD LENGTH=±0.75 (±0.030). MIN.= +DECIMAL PRECISION MAX.= +0.00 -DECIMAL PRECISION



425 N. GARY AVE.
CAROL STREAM, IL 60188
PHONE: 800-278-5666
FAX: 630-315-2152
WEB: WWW.LUMEX.COM

3mm SINGLE UNIT, SMT, VERTICAL LIGHT PIPE.

THE SPECIFICATIONS MAY CHANGE AT ANY TIME WITHOUT NOTICE DUE TO NEW MATERIALS OR PRODUCT IMPROVEMENT.

CONFIDENTIAL INFORMATION
THE INFORMATION CONTAINED IN THIS DOCUMENT IS THE PROPERTY OF LUMEX INC. EXCEPT AS SPECIFICALLY AUTHORIZED IN WRITING BY LUMEX INC., THE HOLDER OF THIS DOCUMENT SHALL KEEP ALL INFORMATION CONTAINED HEREIN CONFIDENTIAL AND SHALL PROTECT SAME IN WHOLE OR IN PART FROM DISCLOSURE AND DISSEMINATION TO ALL THIRD PARTIES.

05.12.16	DRAWN BY: E.C.
PAGE: 1 OF 1	CHKD BY: G.Y.
SCALE: NTS	APRVD BY: Ray
UNIT: mm [INCH]	Ⓜ