

LTC4223 Dual Supply Hot Swap Controller for μ TCA Mezzanine Cards

DESCRIPTION

Demonstration circuit board 1162A allows easy evaluation of the performance of the LTC4223 Dual Hot Swap Controller for Advanced Mezzanine (AMC) Cards. This controller is designed for applications in equipment satisfying the Micro Telecommunications Computing Architecture Specification requirements (+12V main rail with load capability up to 9A and +3.3V auxiliary rail with 150mA load capability). DC1162A includes two printed circuit boards: A simulated carrier board with the LTC4223, 170-pin AMC connector, passive components, and turrets for both

rails. The second board is a simulated AMC mezzanine card, with the same +12V and +3.3V rail outputs as the carrier board. This board also has a typical amount of bypass capacitance onboard, and more may be added externally.

Design files for this circuit board are available. Call the LTC factory.

LT, LTC and LT are registered trademarks of Linear Technology Corporation. ThinSOT and PowerPath are trademarks of Linear Technology Corporation.

PERFORMANCE SUMMARY

Specifications are at $T_A = 25^\circ\text{C}$

| SYMBOL | PARAMETER | CONDITIONS | MIN | TYP | MAX | UNITS |
|-------------------------|--|--|------|-------|------------|-------|
| V_{DD} | Input Supply Range | V _{CC} | 2.7 | | 6.0 | V |
| | | AUXIN | 2.7 | | 6.0 | V |
| | | 12V _{IN} | 10 | | 14 | V |
| $V_{DD(UVLO)}$ | Input Supply Undervoltage Lockout | V _{CC} Rising | 2.3 | 2.45 | 2.6 | V |
| | | AUXIN Rising | 2.4 | 2.5 | 2.6 | V |
| | | 12V _{IN} Rising | 9.4 | 9.7 | 10 | V |
| $\Delta V_{SENSE(CB)}$ | Circuit Breaker Trip Sense Voltage (V _{12IN} - V _{12SENSE}) | | 47.5 | 50 | 52.5 | mV |
| $\Delta V_{SENSE(ACL)}$ | Active Current Limit Sense Voltage, (V _{12IN} - V _{12SENSE}) | V _{IN} = 3.6V | 54 | 60 | 66 | mV |
| I _{AUX(ACL)} | AUXOUT Active Current Limit | V _{AUXOUT} =)V | 165 | 240 | 330 | mA |
| ΔV_{GATE} | External N-Channel Gate Drive (V _{12VGATE} - V _{12VOUT}) | | 4.4 | 6.2 | 7.9 | V |
| I _{GATE(UP)} | External N-Channel Gate Pull-Up Current | Gate Drive On, V _{12VGATE} = 0V | -7 | -10 | -14 | uA |
| I _{GATE(DN)} | External N-Channel Gate Pull-Down Current | Gate Drive Off, V _{12VGATE} = 17V, V _{12VOUT} = 12V | 0.5 | 1 | 2 | mA |
| I _{GATE(FPD)} | External N-Channel Gate Fast Pull-Down Current | Fast Turn Off, V _{12VGATE} = 17V, V _{12VOUT} = 12V | 90 | 160 | 250 | mA |
| G _{12IMON} | 12IMON Pin Gain Ratio $\Delta V_{12IMON} / \Delta (V_{12VIN} - V_{12VSENSE})$ | (V _{12VIN} - V _{12VSENSE}) = (75mV, 25mV) | 30 | 33 | 36 | V/V |
| V _{12IMON} | 12IMON Pin Output Voltage | (V _{12VIN} - V _{12VSENSE}) = 75mV, V _{CC} = 2.7V | 2.25 | 2.475 | 2.7 2.6 | V |

OPERATING PRINCIPLES

The LTC4223 is a dual Hot Swap Controller that satisfies the power requirements and power management of equipment developed in accordance with Advanced Mezzanine Card or MicroTCA specifications. It controls the +12V main supply and +3.3V auxiliary supply power through N-channel MOSFETs. The main power MOSFET is an external component and the auxiliary power MOSFET is integrated in the Controller.

These two rails can be turned on and off independently by their respective ON control signals.

The LTC4223 provides a rich set of features to support hot swap application including:

- Undervoltage lockout on both rails and Vcc,
- Integrated 0.3 Ohm AUX MOSFET,
- Fast (less than 1us) Peak Fault Current limit,
- Circuit Breaker function on Both rails
- Adjustable main rail Current Limit,
- Main rail Load Current Monitoring,
- Gate Drive for External N-Channel MOSFET,
- Adjustable Response Time for Overcurrent Protection,
- Adjustable Supply Voltage Power-Up Rate,
- Thermal Shutdown Protection,
- LTC4223-1: Latch Off After Fault,
- LTC4223-2: Automatic Retry After Fault.

QUICK START PROCEDURE

Demonstration circuit 1162 is easy to set up to evaluate the performance of the LTC2208. Insert the daughter board into the connector. Refer to Figure 1 for proper measurement equipment setup. In the first part of the test, use main board turrets to connect load and voltmeters

1. Place jumpers in the following positions:

JP1 12ON ON
JP2 VCC_SEL AUX
JP3 AUXON ON
JP4 EXT PRESENCE EXT
JP5 RST EXT

2. With power off, connect the power supplies to 12IN, AUXIN, and GND turrets.
3. Disable electronic loads and connect the appropriate terminals to the 12OUT, AUXOUT, and GND turrets.
4. Connect voltmeters to control signals on the $\overline{\text{FAULT}}$, $\overline{\text{12PGOOD}}$, 12MON, and $\overline{\text{AUXPGOOD}}$ turrets.
5. Turn on the 12V and 3.3V supplies. Seven main board green LEDs D4 (12VOUT), D8 (AUXOUT), D5 ($\overline{\text{12PGOOD}}$), D7 ($\overline{\text{AUXPGOOD}}$), D1 (12VIN), D2 (AUXIN), D3 (Vcc), and three daughter board LEDs D11 (12PP), D13 (3.3MP), and D12 (SYS_ENABLE) should light.

Turn on the electronic loads and verify the circuit breaker thresholds: (8.33±0.8) A for 12V rail, and (240±90)mA for the 3.3V rail. In this test, verify that a fault on the +12V rail latches only the +12V rail, $\overline{\text{FAULT}}$ pulls low, $\overline{\text{12VPGOOD}}$ goes high, $\overline{\text{AUXPGOOD}}$ stays low. To reset the fault, pull 12VIN low and then high. A fault on the +3.3V rail latches off both 3.3V and 12V rails. FAULT pulls low, 12VPGOOD and AUXPGOOD go high. To reset the fault, pull both 12ON and AUXON low and than high.

There is an option in using external signals for ON inputs, and Vcc. Change the jumper JP1, JP2, and JP3 position as

JP1 12ON EXT
JP2 VCC_SEL EXT
JP3 AUXON EXT

Use appropriate voltage sources to drive 12ON(E5), AUXIN(E6), EXTVcc(E7), and AUXON(E8) turrets.

6. Reconnect the loads to the daughter board turrets and verify that the LTC4223 demonstrates the same performance. The daughter board also allows observation of turn-on transients when it is plugged into a live carrier board.

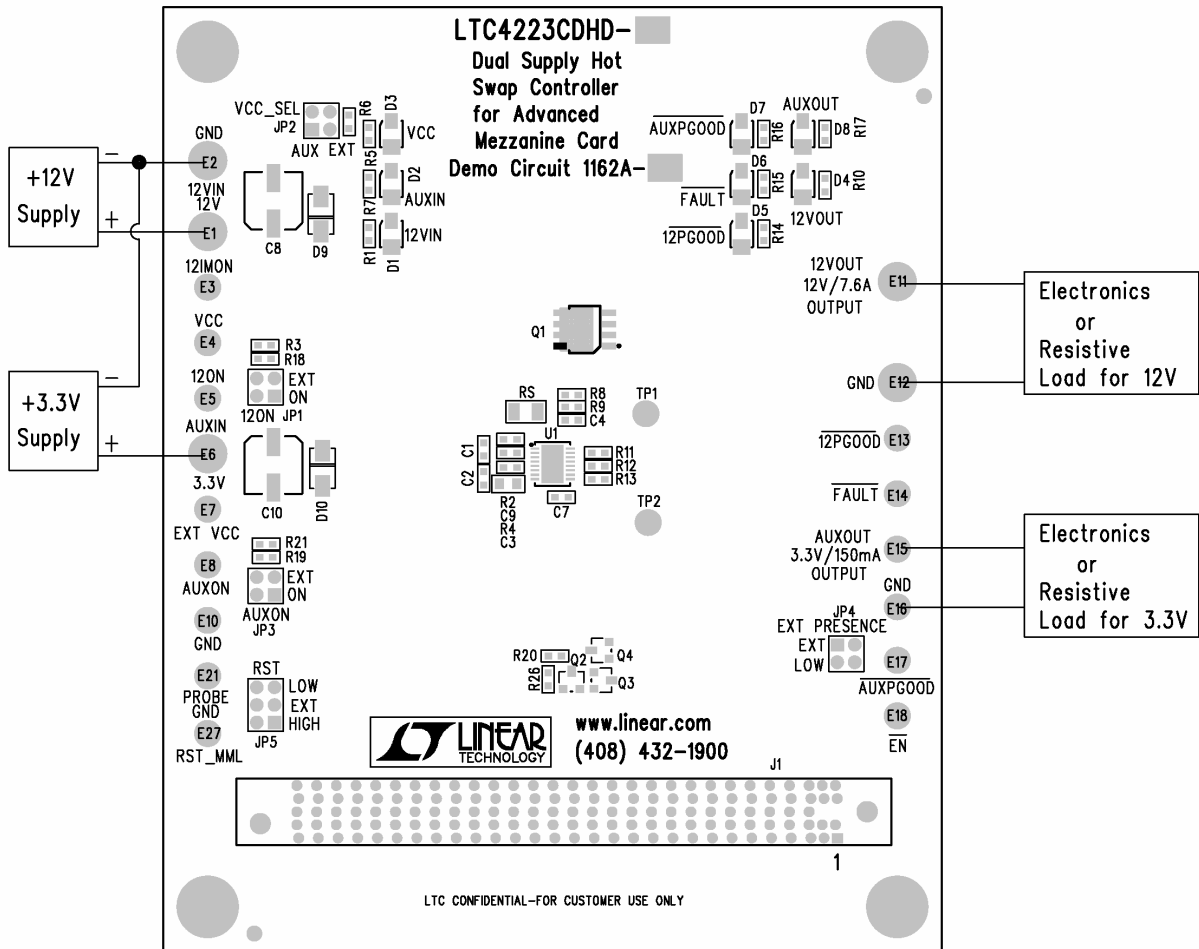

Figure 1. Measurement Equipment Setup

QUICK START GUIDE FOR DEMONSTRATION CIRCUIT 1162

