

# TRADITIONAL JOYSTICK CATEGORIES

## STANDARD JOYSTICKS

Our most popular and versatile unit, the Standard Joystick is available in a variety of configurations to fit your particular application needs. Optional features include: six different centering options, mounting bezels for front or rear panel mounting, a rubber boot seal, various styles and sizes of stick handles, front panel accessible trim features as well as a wide range of output options types and values, which enable you to design the most optimal joystick for your needs.



STANDARD OUTLINE DRAWING

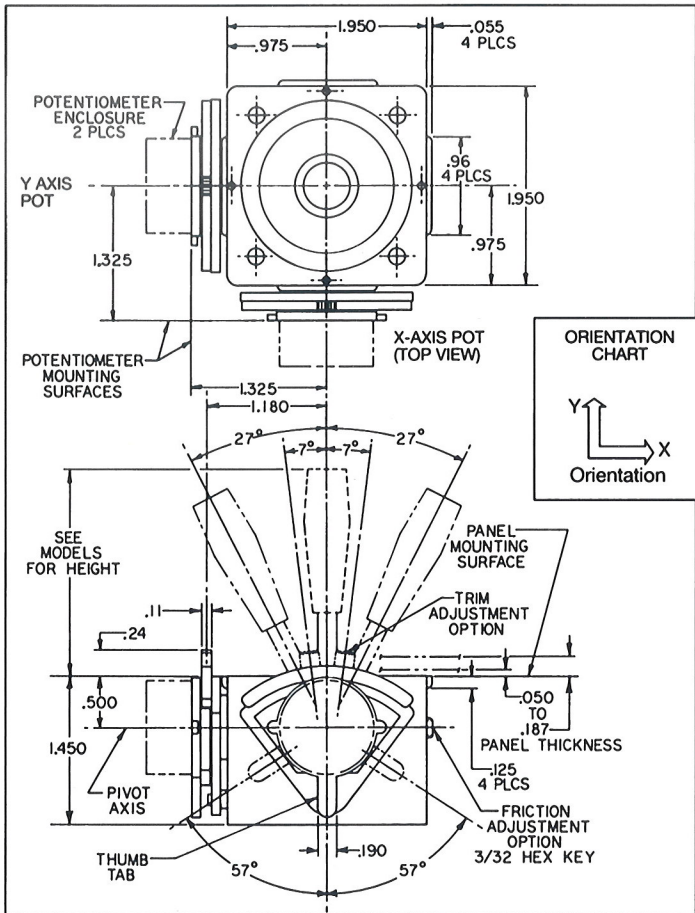

### STANDARD JOYSTICK SPECIFICATIONS

- Joystick travel - 30° from design center in all directions
- Mechanical lifecycle - 5,000,000 (minimum)
- Trim movement (optional) - ±7° (total trim 14°) for each axis
- Main pivot ball - precision ground stainless steel
- Stick shaft - 3/16in. brass plated
- Return to center repeatability - ± 2%
- Mounting - front or rear panel (see bezels)
- Panel thickness (mounting) - .050in. to .1875in.
- Deflection force - .14lbs. @ 27° @ 2 7/8in. up from pivot point
- Potentiometer calibration - thumb tab provides 114° of calibration
- Potentiometers - set at center of resistance
- or -
- Non-contacting Hall Effect sensors

# Model 300

## MODEL 300

(Three-Axes Joystick Assemblies) -The Model 300 joystick with Option 8 handle, is a three-axis, zero button joystick with a black spring-return-to-center textured knob on the stick handle providing a third axis. The Model 300 joystick comes equipped with a two-piece mounting bezel or an optional rubber boot seal.



### OPTION 8

The Option 8 handle uses a 5kΩ, 1 Watt potentiometer housed within the knob, and can be rotated a total of 90°, ±45° from design center with .4in./lbs. of torque needed to initiate the rotation of the knob. Option 8 is a double-scissor, extension-type spring-action control knob with positive stops.

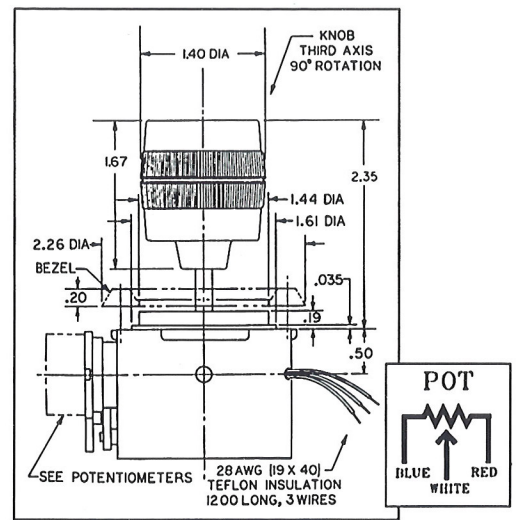

Option 8 handle

# 400 Model 400

## MODEL 400

(Three-Axes with Pushbutton Joystick Assemblies) – The Model 400 is a three-axis joystick with a black spring-return-to-center textured knob and a pushbutton switch located at the top of the control knob. The switch on the Model 400 assembly is a normally open, single pole/single throw momentary contact switch. Options include a two-piece mounting bezel, rubber boot and IBM gray pushbutton.

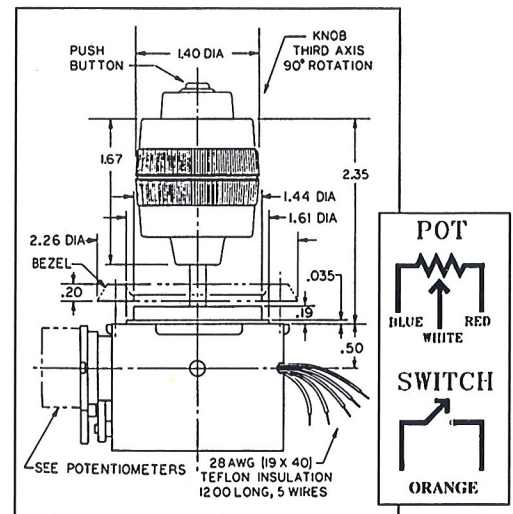

Option 9 handle

### OPTION 9

The Option 9 switch is a 5,000,000 life cycle switch rated at 500mA at 12VDC.

# BEZELS

## MOUNTING BEZELS

CH Products offers a variety of textured finish front mount (FM) or rear mount (RM) panel mounting bezels. All front mount bezels are sent with 2 sets (4 screws per set) of mounting screws (1/2in. and 1/4in. with 2/56 threading, Phillips flathead) with optional 3/8in. screws available upon request. All rear mount bezels are sent with two sets of non-anodized mounting screws (1/2in. and 1/4in. with 2/56 threading, Phillips flathead) with optional 5/16in. screws also available upon request. Please note: not all bezels are available with all joystick models. Check configuration guide for availability.

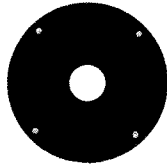

A- Round Bezel Textured (FM)  
Cutout  
Standard- 1.625 in.

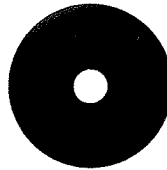

C- Split Bezel Textured (FM)  
Cutout  
Standard- 1.50in.  
Miniature- 1.562in.

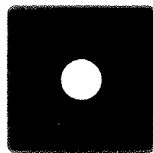

F- Square Bezel Textured (RM)  
Cutout  
Standard- 1.312in.  
Miniature- 1.187in.



L- Rubber Boot Kit & Mounting  
Ring Textured (FM)  
Cutout  
Standard- 1.562in.  
Miniature- 1.562in.



O- Computer Bezel  
Cutout  
Compact- 1.213in.



Q- Square Bezel Snap-on (FM)  
Cutout  
Standard- 1.437in.  
Miniature- 1.250in.



U- Round Bezel Snap-on (FM)  
Cutout  
Standard- 1.625in.

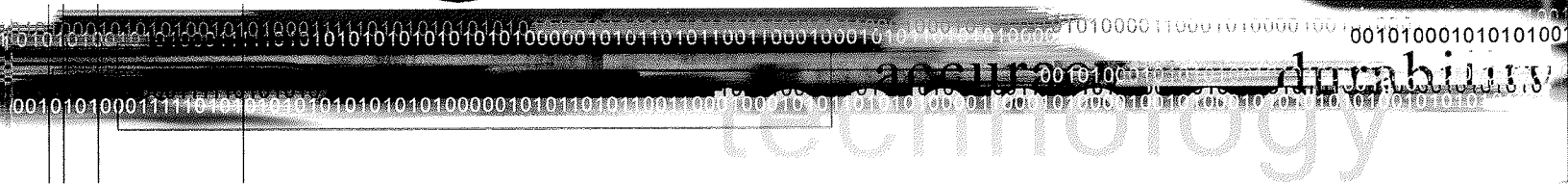

# OPTIONS

## OUTPUT OPTIONS POTENTIOMETER

### CLAROSTAT 595 (F) AND CLAROSTAT 388 (C)

- Electrical element: Conductive plastic
- Resistance (ohms): 5K (F) & 10K (C)
- Tolerance:  $\pm 20\%$
- Power rating: 0.5W
- Linearity:  $\pm 5\%$
- Temperature range (°C): -55° to +120°
- CRV (Contact Resistance Variation):  $\pm 1.5\%$
- Electrical travel: 265°
- Mechanical rotation: 295°
- Terminals: Solder Lug & J Hooks
- Rotational life cycle: 1,000,000 & 50,000

**F 5K**



**C 10K**



### CTS HP SERIES (J, L)

- Electrical element: Conductive carbon
- Resistance (ohms): 100k & 130K
- Tolerance:  $\pm 9\%$ ,  $\pm 5\%$
- Power rating: 0.25W
- Linearity:  $\pm 5\%$
- Temperature Range (C°): 0° to 85°
- CRV (Contact Resistance Variation): 1%
- Electrical travel: 50°
- Mechanical rotation: 300°
- Terminals: Solder Lug
- Rotational life cycle: 2,000,000

**J 100K**

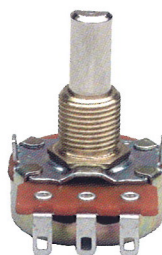

**L 130K**

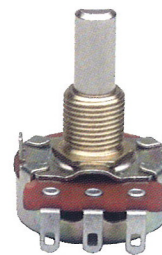

### SENSORCUBE (R, U)

- Electrical element: Conductive plastic
- Resistance (ohms): Standard : 5K & 10K
- Miniature: 5K
- Tolerance:  $\pm 10\%$
- Power rating: 1W
- Linearity:  $\pm 1\%$
- Temperature Range (C°): -65° to +125°
- CRV (Contact Resistance Variation): 1%
- Electrical travel: Standard : 56° & 265°  
Miniature: 50°
- Mechanical rotation: Standard: 310° & 360°  
Miniature: 360°
- Terminals: Solder Lug
- Rotational Life cycle: 10,000,000

**R 5K**



**U 10K**



### AVAILABLE RESISTANCE CALCULATION

Total available resistance depends on a combination of potentiometer type and joystick model selection. The available resistance range can be obtained using the formula below:

$$\frac{\text{Total Potentiometer Resistance (ohms)}}{\text{Potentiometer Electrical Travel (degrees)}} \times \text{Joystick Mechanical Travel (degrees)} = \text{Available Resistance Range (ohms)}$$