

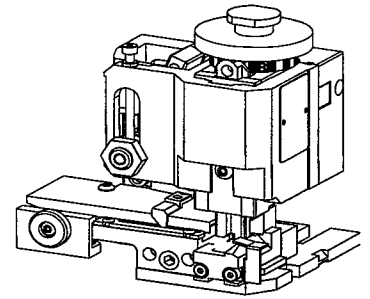

SPECIFICATION SHEET
FineAdjust Applicator
63863-5000
REVISION A



SCOPE

| Terminal Series No | | Wire Size Awg | Wire Size (mm ²) | Insulation Diameter mm | Insulation Diameter (in) | Strip Length mm | Strip Length (in) |
|--------------------|----------|------------------|---------------------------------|---------------------------|-----------------------------|--------------------|----------------------|
| 50397-8* | 50398-8* | 22-28 | (0.34-0.079) | 1.8-1.15 | (.071-.045) | 2.6-3.1 | (.102-.122) |
| | | | | | | | |
| | | | | | | | |
| | | | | | | | |

DEFINITION OF TERMS

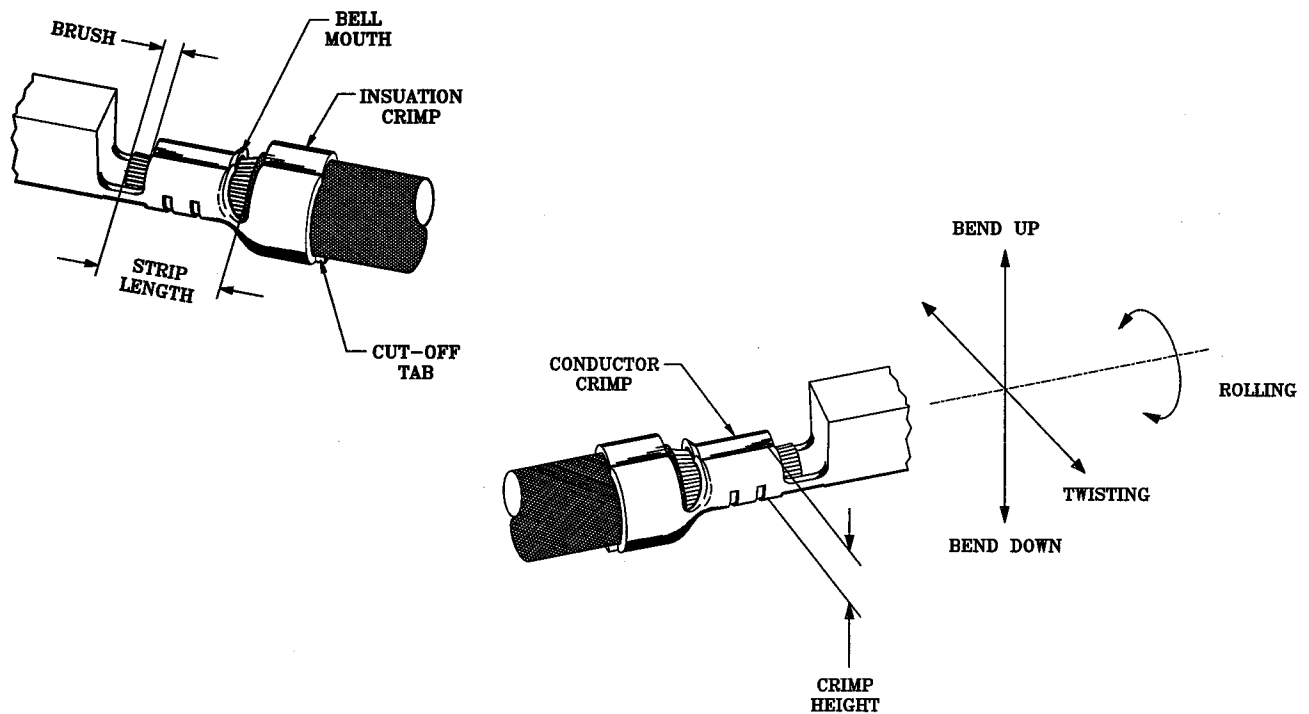

The above terminal drawing is a generic terminal representation. It is not an image of a terminal listed in the scope

SPECIFICATIONS

| Terminal Series No. | | Bellmouth mm (in) | | Cut-Off Tab Max. mm (in) | | Conductor Brush mm (in) | |
|---------------------|----------|----------------------|-------------|-----------------------------|--------|----------------------------|-------------|
| 50397-8* | 50398-8* | 0.05-0.60 | (.002-.023) | 0.2 | (.008) | 0-0.8 | (.000-.031) |
| | | | | | | | |
| | | | | | | | |

| Terminal Series No. | | Bend Up Degree | Bend Down Degree | Twist Degree | Roll | Punch Width mm Conductor Insulation | |
|---------------------|----------|-------------------|---------------------|-----------------|------|--|------|
| 50397-8* | 50398-8* | 3 | 3 | 3 | 6 | 1.20 | 1.80 |
| | | | | | | | |
| | | | | | | | |

The above specifications are guidelines to an optimum crimp.

CONDITIONS

After crimping, the conductor profile should measure the following.

| Terminal Series | | Wire Size Awg (mm ²) | | Crimp Height mm (in) | | Pull Force Min N (lbs) | |
|-----------------|----------|-------------------------------------|--------|-------------------------|-------------|---------------------------|--------|
| 50397-8* | 50398-8* | 22 | (0.35) | 0.84-0.89 | (.033-.035) | 39.2 | (8.80) |
| 50397-8* | 50398-8* | 24 | (0.20) | 0.76-0.81 | (.030-.032) | 29.4 | (6.60) |
| 50397-8* | 50398-8* | 26 | (0.12) | 0.71-0.76 | (.028-.030) | 19.6 | (4.40) |
| 50397-8* | 50398-8* | 28 | (0.80) | 0.67-0.72 | (.026-.028) | 9.8 | (2.20) |
| | | | | | | | |
| | | | | | | | |
| | | | | | | | |
| | | | | | | | |
| | | | | | | | |
| | | | | | | | |
| | | | | | | | |
| | | | | | | | |
| | | | | | | | |
| | | | | | | | |
| | | | | | | | |

Pull Force measured with no influence from the insulation crimp

PARTS LIST

| Item Number | Order Number | Eng Number | Description | Qty | Kit Part |
|-------------|--------------|------------|--------------------------|-----|----------|
| 1 | 63444-1212 | 634441212 | Conductor Punch | 1 | Y |
| 2 | 63445-1221 | 634451221 | Conductor Anvil | 1 | Y |
| 3 | 63446-1815 | 634461815 | Insulation Punch | 1 | Y |
| 4 | 63445-1824 | 634451824 | Insulation Anvil | 1 | Y |
| 5 | 63443-0002 | 634430002 | Cut-Off Plunger | 1 | Y |
| 6 | 63443-0012 | 634430012 | Front Plunger Retainer | 1 | Y |
| 7 | 011-24-1067 | 4996-4 | Cut-Off Plunger Spring | 1 | |
| 8 | 011-40-4039 | 8302-5 | Front Plunger Striker | 1 | |
| 9 | 63443-0021 | 634430021 | Lower Tooling Key | 1 | |
| 10 | 63443-6003 | 634436003 | Rear Cover | 1 | |
| 11 | 011-18-4083 | 60707-8 | Front Cover | 1 | |
| 12 | 63443-2406 | 634432406 | Anvil Mount | 1 | |
| 13 | 63443-4005 | 634434005 | Wire Stop | 1 | |
| 14 | 63443-0009 | 634430009 | Scrap Chute | 1 | |
| 15 | 63800-4900 | 638004900 | FineAdjust Applicator | 1 | |
| 70 | 63863-5070 | 638635070 | Tool Kit (All "Y" Items) | 0 | |

NOTES

1. We recommend an extra perishable tooling kit be maintained at your facility.
2. Verify tooling alignment by manually cycling the press and Applicator before crimping under power.
3. Slugs , Terminals, Dirt and Oil should be kept clear of work area.
4. This Applicator should only be used in a press with a shut height of 135.8 mm (5.346"). Tooling damage could result at a lower setting.
5. **** CAUTION**** To prevent injury never operate this Applicator without the guarding supplied with the press or wire processing machine in place. Reference the press or wire processing manufacturer's instruction manual.
6. Wear safety glasses at all times.

ASSEMBLY DRAWING

The drawing below is a generic drawing representation. Some detail may not be shown. The FineAdjust applicator assembly and parts list can be found in the FineAdjust manual.

