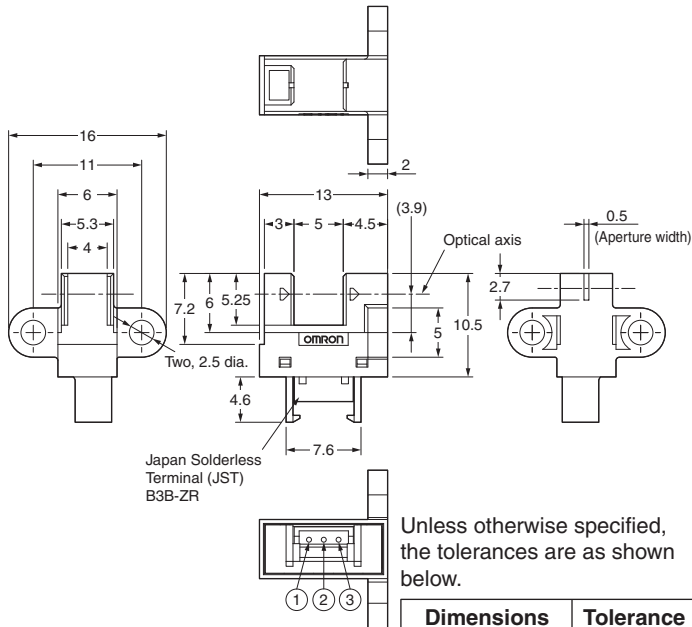

Photo IC Output Photomicrosensor (Transmissive) EE-SX3157-P1/EE-SX4157E-P1

■ Dimensions

Note: All units are in millimeters unless otherwise indicated.



Terminal No.	Name
1	Power supply (V _{CC})
2	Output (OUT)
3	Ground (GND)

Dimensions	Tolerance
3 mm max.	±0.200
3 < mm ≤ 6	±0.240
6 < mm ≤ 10	±0.290
10 < mm ≤ 18	±0.350
18 < mm ≤ 30	±0.420

Recommended Mating Connectors:
JST (Japan Solderless Terminal) ZHR-3

■ Electrical and Optical Characteristics (Ta = 25°C, V_{CC} = 12 V ±10%)

Item	Symbol	Value	Condition
Current consumption	I _{CC}	25 mA max.	With and without incident
Low-level output voltage	V _{OL}	0.3 V max.	I _{OUT} = 16 mA without incident (EE-SX3157-P1) with incident (EE-SX4157E-P1)
High-level output voltage	V _{OH}	(V _{CC} × 0.9) V min.	V _{OUT} = V _{CC} , R _L = 47 kΩ with incident (EE-SX3157-P1) without incident (EE-SX4157E-P1)
Response frequency	f	3 kHz min.	V _{OUT} = V _{CC} , R _L = 47 kΩ (see note)

Note: The value of the response frequency is measured by rotating the disk as shown below.

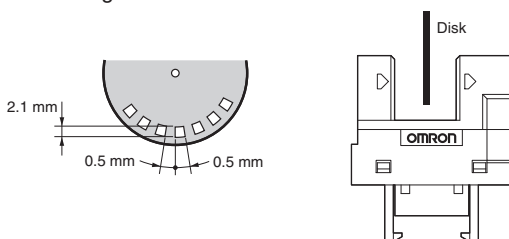

■ Features

- Through-beam Photomicrosensors with 5-mm slot.
- High resolution (aperture width: 0.5 mm).
- Light-ON operation with open-collector output. (EE-SX4157E-P1)
- Dark-ON operation with open-collector output. (EE-SX3157-P1)
- Screw mounting and connector connection (compatible with ZHR-3 from J.S.T. Mfg. Co., Ltd.).
- Connector lock mechanism.

■ Absolute Maximum Ratings (Ta = 25°C)

Item	Symbol	Rated value	
Power supply voltage	V _{CC}	13.2 VDC	
Output voltage	V _{OUT}	13.2 V	
Output current	I _{OUT}	16 mA	
Permissible output dissipation	P _{OUT}	250 mW (see note)	
Ambient temperature	Operating	T _{opr}	-20°C to 85°C
	Storage	T _{stg}	-30°C to 85°C
Soldering temperature	T _{sol}	---	

Note: Refer to the temperature rating chart if the ambient temperature exceeds 25°C.

■ Engineering Data

Output Allowable Dissipation vs. Ambient Temperature Characteristics

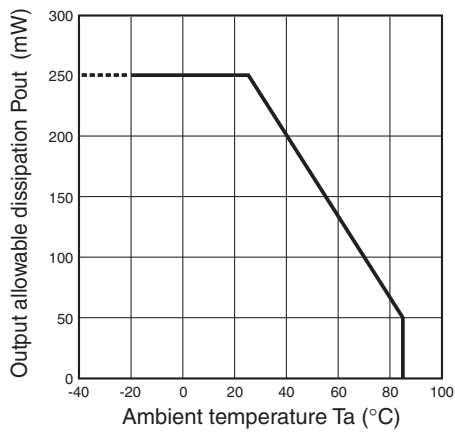

Sensing Position Characteristics (Typical)

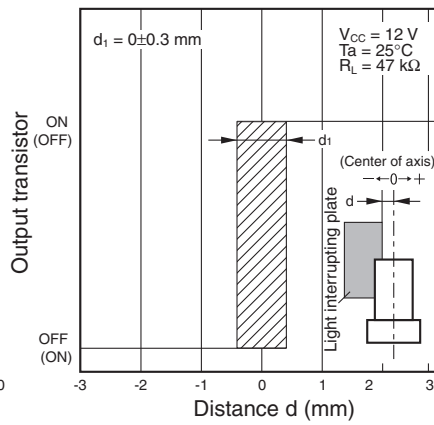

Sensing Position Characteristics (Typical)

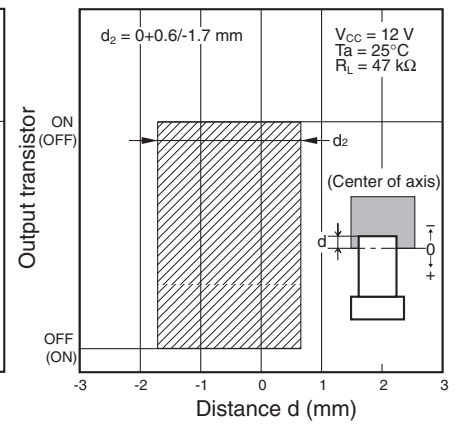

- Application examples provided in this document are for reference only. In actual applications, confirm equipment functions and safety before using the product.
- Consult your OMRON representative before using the product under conditions which are not described in the manual or applying the product to nuclear control systems, railroad systems, aviation systems, vehicles, combustion systems, medical equipment, amusement machines, safety equipment, and other systems or equipment that may have a serious influence on lives and property if used improperly. Make sure that the ratings and performance characteristics of the product provide a margin of safety for the system or equipment, and be sure to provide the system or equipment with double safety mechanisms.

Note: Do not use this document to operate the Unit.